

DSC-P1

SERVICE MANUAL

Level 2

Self Diagnosis
Supported model

Ver 1.0 2000. 10

Cyber-shot
Digital Still Camera

InfoLITHIUM **S**



MEMORY STICK



*US Model
Canadian Model
AEP Model
UK Model
E Model
Hong Kong Model
Australian Model
Chinese Model
Korea Model
Tourist Model
Japanese Model*

This service manual contains information for Japanese model as well.

**When the machine needs to be repaired,
please refer to page 6 to discriminate the
type of LCD.**

On the BT-2, CA-66, DD-150, HI-74, MT-60, PS-440 boards

This service manual provides the information that is premised the circuit board replacement service and not intended repair inside the BT-2, CA-66, DD-150, HI-74, MT-60, PS-440 boards.

Therefore, schematic diagram, printed wiring board and electrical parts list of the BT-2, CA-66, DD-150, HI-74, MT-60, PS-440 boards are not shown.

The following pages are not shown.

BT-2 board

Schematic diagram Page 4-75 to 4-76
Printed wiring board Page 4-73 to 4-74
Electrical parts list Page 6-5

CA-66 board

Schematic diagram Page 4-11 to 4-14
Printed wiring board Page 4-9 to 4-10
Electrical parts list Page 6-5 to 6-6

DD-150 board

Schematic diagram Page 4-79 to 4-80
Printed wiring board Page 4-77 to 4-78
Electrical parts list Page 6-6 to 6-7

HI-74 board

Schematic diagram Page 4-43 to 4-50
Printed wiring board Page 4-39 to 4-42
Electrical parts list Page 6-7 to 6-10

MT-60 board

Schematic diagram Page 4-19 to 4-26
Printed wiring board Page 4-15 to 4-18
Electrical parts list Page 6-10

PS-440 board

Schematic diagram Page 4-31 to 4-38
Printed wiring board Page 4-27 to 4-30
Electrical parts list Page 6-10 to 6-11

The above-described information is shown in service manual Level 3.

DIGITAL STILL CAMERA

SONY[®]

SPECIFICATIONS

System

Image device

1/1.8 type color CCD

Lens

3× zoom lens

f = 8 – 24 mm

(39 – 117 mm when converted into a 35 mm still camera)

F = 2.8 – 5.3

Exposure control

Automatic exposure

White balance

Automatic, Indoor, Outdoor,

Hold

Data system

Movie: MPEG1

Still: JPEG, GIF (in TEXT

mode, Clip Motion), TIFF

Audio with still image:

MPEG1 (Monaural)

Recording medium

“Memory Stick”

Flash

Recommended recording

distance:

W side: 1 5/8 feet to 7 1/2 feet

(0.5 m to 2.3 m)

T side: 1 5/8 feet to 3 7/8 feet

(0.5 m to 1.2 m)

Output connector

A/V OUT (Monaural)

Minijack

Video: 1 Vp-p, 75 Ω,

unbalanced, sync negative

Audio: 327 mV (at a 47 kΩ

load)

Output impedance: 2.2 kΩ

USB jack

mini-B

LCD screen

Used LCD panel

1.5 type TFT (Thin Film

Transistor active matrix) drive

Total number of dots

123 200 (560×220) dots

General

Used battery pack

NP-FS11

Power requirements

3.6 V

Power consumption

(during recording)

3.0 W

Operation temperature

32°F to 104°F

(0°C to 40°C)

Storage temperature

–4°F to +140°F

(–20°C to +60°C)

Dimensions

4 1/2×2 1/8×1 3/4 inches

(113.0×53.9×43.8 mm) (w/h/d)

(excluding maximum

protrusions)

Mass

Approx. 8.8 oz (250 g)

(including battery pack NP-

FS11, “Memory Stick,” and

wrist strap etc.)

Built-in microphone

Electret condenser microphone

Built-in speaker

Dynamic speaker

AC-LS1A AC power adaptor

Power requirements

100 to 240 V AC, 50/60 Hz

Rated output voltage

DC 4.2 V, 1.5 A in operating

mode

Operation temperature

32°F to 104°F (0°C to 40°C)

Storage temperature

–4°F to +140°F

(–20°C to +60°C)

Maximum dimensions

4 1/4×1 7/16×2 1/4 inches

(105×36×56 mm) (w/h/d)

(excluding maximum

protrusions)

Mass

Approx. 6 oz (180 g)

(power adaptor only)

NP-FS11 battery pack

Used battery

Lithium ion battery

Maximum voltage

DC 4.2 V

Nominal voltage

DC 3.6 V

Capacity

4.1 Wh (1 140 mAh)

Dimensions

1 1/4×2 1/32×2 inches

(30.3×16.3×50.2 mm) (w/h/d)

Mass

Approx. 1.4 oz (40 g)

Accessories

A/V connecting cable (1)

NP-FS11 battery pack (1)

AC-LS1A AC power adaptor (1)

Power cord (1)

USB cable (1)

Wrist strap (1)

“Memory Stick” (8 MB) (1)

CD-ROM (1)

Operating Instructions (1)

Design and specifications are subject to change without notice.

SAFETY-RELATED COMPONENT WARNING!!

COMPONENTS IDENTIFIED BY MARK \triangle OR DOTTED LINE WITH MARK \triangle ON THE SCHEMATIC DIAGRAMS AND IN THE PARTS LIST ARE CRITICAL TO SAFE OPERATION. REPLACE THESE COMPONENTS WITH SONY PARTS WHOSE PART NUMBERS APPEAR AS SHOWN IN THIS MANUAL OR IN SUPPLEMENTS PUBLISHED BY SONY.

ATTENTION AU COMPOSANT AYANT RAPPORT À LA SÉCURITÉ!

LES COMPOSANTS IDENTIFIÉS PAR UNE MARQUE \triangle SUR LES DIAGRAMMES SCHÉMATIQUES ET LA LISTE DES PIÈCES SONT CRITIQUES POUR LA SÉCURITÉ DE FONCTIONNEMENT. NE REMPLACER CES COMPOSANTS QUE PAR DES PIÈCES SONY DONT LES NUMÉROS SONT DONNÉS DANS CE MANUEL OU DANS LES SUPPLÉMENTS PUBLIÉS PAR SONY.

SAFETY CHECK-OUT

After correcting the original service problem, perform the following safety checks before releasing the set to the customer.

1. Check the area of your repair for unsoldered or poorly-soldered connections. Check the entire board surface for solder splashes and bridges.
2. Check the interboard wiring to ensure that no wires are “pinched” or contact high-wattage resistors.
3. Look for unauthorized replacement parts, particularly transistors, that were installed during a previous repair. Point them out to the customer and recommend their replacement.
4. Look for parts which, though functioning, show obvious signs of deterioration. Point them out to the customer and recommend their replacement.
5. Check the B+ voltage to see it is at the values specified.
6. Flexible Circuit Board Repairing
 - Keep the temperature of the soldering iron around 270 °C during repairing.
 - Do not touch the soldering iron on the same conductor of the circuit board (within 3 times).
 - Be careful not to apply force on the conductor when soldering or unsoldering.

TABLE OF CONTENTS

| <u>Section</u> | <u>Title</u> | <u>Page</u> | <u>Section</u> | <u>Title</u> | <u>Page</u> |
|--|--------------|-------------|--|--|-------------|
| SERVICE NOTE | | 5 | | ZM-26 Printed Wiring Board and Schematic Diagram | 4-71 |
| 1. GENERAL | | | 4-3. Waveforms | | 4-82 |
| Identifying the Parts | | 1-1 | 4-4. Parts Location | | 4-85 |
| Preparing the Power Supply | | 1-2 | 5. ADJUSTMENTS | | |
| Setting the Date and Time | | 1-3 | Before Starting Adjustment | | 5-1 |
| Inserting the "Memory Stick" | | 1-3 | 1-1. Adjusting Items when Replacing Main Parts and Boards | | 5-2 |
| Recording Still Images | | 1-4 | 5-1. Camera Section Adjustment | | 5-3 |
| Recording Moving Images | | 1-5 | 1-1. Preparations Before Adjustment | | 5-3 |
| Playing Back Still Images | | 1-5 | 1-1-1. List of Service Tools | | 5-3 |
| Playing Back Moving Images | | 1-6 | 1-1-2. Preparations | | 5-4 |
| Viewing Images Using a Personal Computer | | 1-6 | 1-1-3. Discharging of the Flashlight Power Supply | | 5-4 |
| Image File Storage Destinations and Image Files | | 1-7 | 1-1-4. Precautions | | 5-6 |
| Before Performing Advanced Operations | | 1-8 | 1. Setting the Switch | | 5-6 |
| Various Recording | | 1-10 | 2. Order of Adjustments | | 5-6 |
| Various Playback | | 1-12 | 3. Subjects | | 5-6 |
| Editing | | 1-13 | 4. Preparing the Flash Adjustment Box | | 5-7 |
| Additional Information | | 1-14 | 1-2. Initialization of B, D, E, F, 7 Page Data | | 5-8 |
| Troubleshooting | | 1-15 | 1-2-1. Initialization of D Page Data | | 5-8 |
| Warning and Notice Messages | | 1-16 | 1. Initializing D Page Data | | 5-8 |
| Self-diagnosis Display | | 1-16 | 2. Modification of D Page Data | | 5-8 |
| Display Window Indicators | | 1-16 | 3. D Page Table | | 5-8 |
| LCD Screen Indicators | | 1-16 | 1-2-2. Initialization of B, E, F, 7 Page Data | | 5-9 |
| 2. DISASSEMBLY | | | 1. Initializing B, E, F, 7 Page Data | | 5-9 |
| • Attachment of CPC-9 Jig | | 2-2 | 2. Modification of B, E, F, 7 Page Data | | 5-9 |
| 2-1. BT Lid Assembly Replacing Method | | 2-2 | 3. B Page Table | | 5-9 |
| 2-2. Rear Cabinet Block | | 2-4 | 4. E Page Table | | 5-9 |
| 2-3. PD-137 Board | | 2-4 | 5. F Page Table | | 5-10 |
| 2-4. ZM-26 Board | | 2-4 | 6. 7 Page Table | | 5-11 |
| 2-5. SW-349 Board | | 2-5 | 1-3. Video System Adjustments | | 5-12 |
| 2-6. LCD Module | | 2-5 | 1. Video Sync Level Adjustment | | 5-12 |
| 2-7. Aluminum Cabinet (Rear) Assembly Replacing Method | | 2-6 | 2. Video Burst Level Check | | 5-12 |
| 2-8. Inner Cabinet (Rear) Assembly Replacing Method | | 2-7 | 1-4. Camera System Adjustment | | 5-13 |
| 2-9. Jack Cover Replacing Method | | 2-8 | 1. Flange Back Adjustment (Using the Minipattern Box) .. | | 5-14 |
| 2-10. Upper Cabinet Block | | 2-9 | 2. Flange Back Adjustment (Using the Flange Back Adjustment Chart) | | 5-15 |
| 2-11. PW-122 Board | | 2-9 | 3. Flange Back Check | | 5-16 |
| 2-12. Lens Block | | 2-9 | 4. F No. Standard Data Input | | 5-16 |
| 2-13. CA-66, PS-440 Boards | | 2-10 | 5. Mechanical Shutter Adjustment | | 5-17 |
| 2-14. DD-150 Board | | 2-11 | 6. Picture Frame Setting | | 5-18 |
| 2-15. ST-62 Board | | 2-11 | 7. Light Level Adjustment | | 5-19 |
| 2-16. HI-74 Board | | 2-11 | 8. Auto White Balance Standard Data Input | | 5-19 |
| 2-17. MT-60 Board | | 2-11 | 9. Auto White Balance Adjustment | | 5-20 |
| 2-18. Circuit Boards Location | | 2-12 | 10. Smear Compensation Adjustment | | 5-21 |
| 3. BLOCK DIAGRAMS | | | 11. Color Reproduction Adjustment | | 5-21 |
| 3-1. Overall Block Diagram | | 3-1 | 12. Color Reproduction Check | | 5-22 |
| 3-8. Power Block Diagram 1 | | 3-15 | 13. Auto White Balance Check | | 5-23 |
| 3-9. Power Block Diagram 2 | | 3-17 | 14. Strobe White Balance Adjustment | | 5-24 |
| 4. PRINTED WIRING BOARDS AND SCHEMATIC DIAGRAMS | | | 15. CCD Black Defect Compensation | | 5-25 |
| 4-1. Frame Schematic Diagrams | | 4-3 | 16. CCD White Defect Compensation | | 5-25 |
| Frame Schematic Diagram (1/2) | | 4-3 | 1-5. LCD System Adjustments | | 5-26 |
| Frame Schematic Diagram (2/2) | | 4-5 | 1. LCD Initial Data Input | | 5-27 |
| 4-2. Printed Wiring Boards and Schematic Diagrams | | 4-7 | 2. VCO Adjustment (PD-137 Board) | | 5-28 |
| CD-290 Printed Wiring Board and Schematic Diagram | | 4-7 | 3. Black Limit Adjustment (PD-137 Board) | | 5-29 |
| PW-122 Printed Wiring Board | | 4-51 | 4. Bright Adjustment (PD-137 Board) | | 5-29 |
| PW-122 Schematic Diagram | | 4-53 | 5. Contrast Adjustment (PD-137 Board) | | 5-30 |
| ST-62 Printed Wiring Board | | 4-55 | 6. Color Adjustment (PD-137 Board) | | 5-30 |
| ST-62 Schematic Diagram | | 4-59 | 7. VG Center Adjustment (PD-137 Board) | | 5-31 |
| PD-137 Printed Wiring Board | | 4-61 | 8. V-COM Adjustment (PD-137 Board) | | 5-31 |
| PD-137 (CONNECTION) Schematic Diagram | | 4-63 | 9. White Balance Adjustment (PD-137 Board) | | 5-32 |
| PD-137 (LCD DRIVE, TIMING GENERATOR) Schematic Diagram | | 4-65 | 1-6. System Control System Adjustments | | 5-33 |
| SW-349 Printed Wiring Board | | 4-67 | 1. Battery Down Adjustment | | 5-33 |
| SW-349 Schematic Diagram | | 4-69 | 5-2. Service Mode | | 5-34 |
| | | | 2-1. Adjusting Remote Commander | | 5-34 |
| | | | 1. Used the Adjusting Remote Commander | | 5-34 |
| | | | 2. Precautions upon Using the Adjusting Remote Commander | | 5-34 |
| | | | 2-2. Data Process | | 5-35 |
| | | | 2-3. Service Mode | | 5-36 |
| | | | 1. Setting the Test Mode | | 5-36 |
| | | | 2. Bit Value Discrimination | | 5-36 |

| <u>Section</u> | <u>Title</u> | <u>Page</u> |
|----------------------|-----------------------------|-------------|
| 3. | Switch Check (1) | 5-36 |
| 4. | Switch Check (2) | 5-37 |
| 5. | LED, LCD Check | 5-37 |
| 6. REPAIR PARTS LIST | | |
| 6-1. | Exploded Views | 6-1 |
| 6-1-1. | Upper Cabinet Section | 6-1 |
| 6-1-2. | Rear Panel Section | 6-2 |
| 6-1-3. | Main Section | 6-3 |
| 6-2. | Electrical Parts List | 6-4 |

| |
|--|
| * The color reproduction frame is shown on page 131. |
|--|

SERVICE NOTE

• NOTE FOR REPAIR

Make sure that the flat cable and flexible board are not cracked or bent at the terminal.

Do not insert the cable insufficiently nor crookedly.

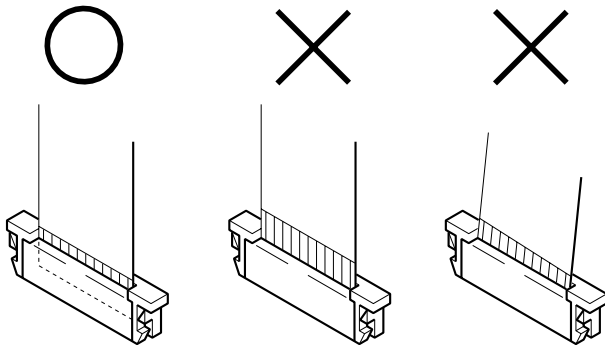

Cut and remove the part of gilt which comes off at the point.
(Be careful or some pieces of gilt may be left inside)

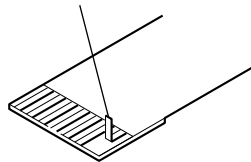

[Discharging of the ST-62 board's charging capacitor (C1003)]

The charging capacitor (C1003) of the ST-62 board is charged up to the maximum 300 V potential.

There is a danger of electric shock by this high voltage when the battery is handled by hand. The electric shock is caused by the charged voltage which is kept without discharging when the main power of the unit is simply turned off. Therefore, the remaining voltage must be discharged as described below.

Preparing the Short Jig

To preparing the short jig, a small clip is attached to each end of a resistor of 1 k Ω / 1 W (1-215-869-11).

Wrap insulating tape fully around the leads of the resistor to prevent electrical shock.

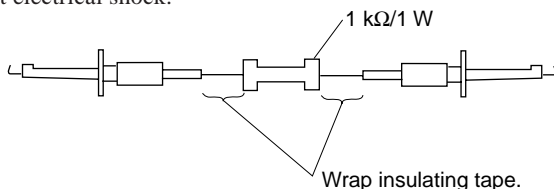

Discharging the Capacitor

Short-circuit between the positive and the negative terminals of charged capacitor with the short jig about 10 seconds.

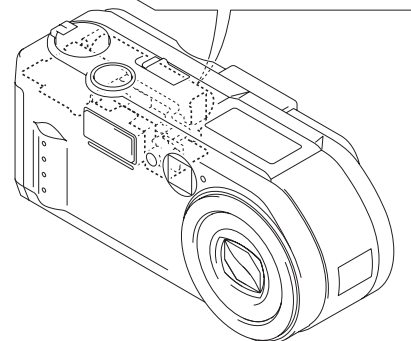
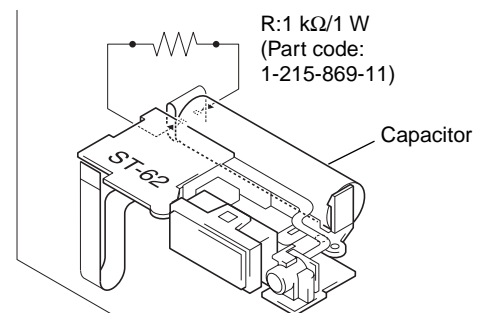

[LCD type check]

By measuring the resistor value between Pin ⑬ of CN881 and Pin ④ of CN881 on PD-137 board, the type of LCD can be discriminated.

Note: About PD-137 board and LCD module, discriminate LCD type on the machine, and replace the same type.

PD-137 board CN881

| Resistor value | LCD type | PD board |
|----------------|----------|------------------|
| 10 k Ω | TYPE SA | PD-137 (TYPE SA) |
| 22 k Ω | TYPE ST | PD-137 (TYPE ST) |

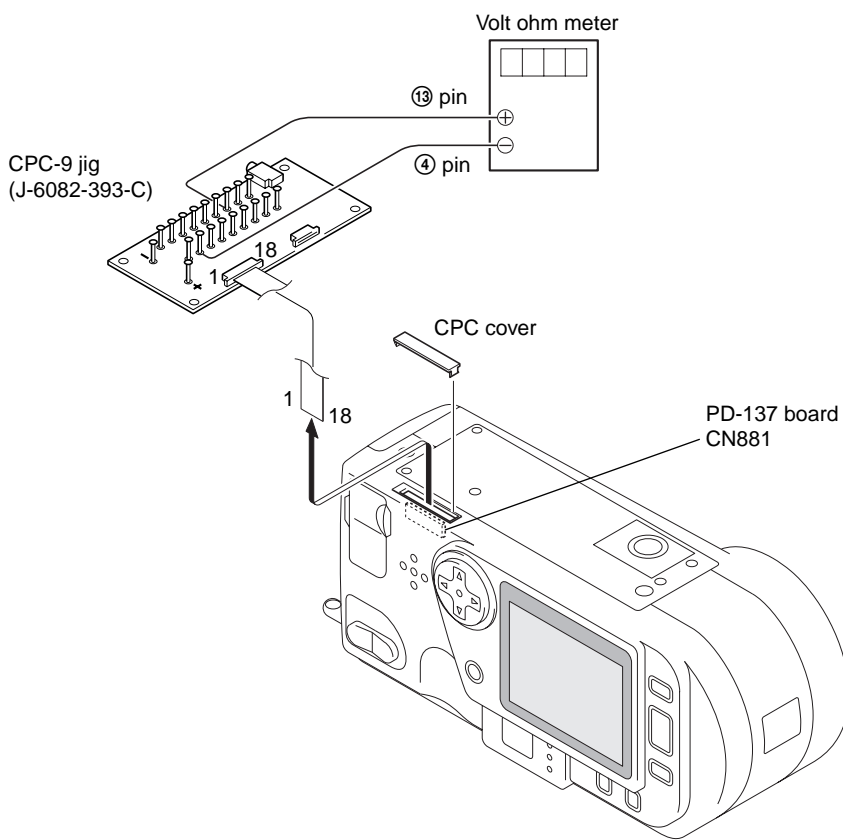

Note 1: Don't use the 12 pin flexible board of CPC-9 jig.
It causes damage to the unit.

Note 2: The old CPC-9 jig (Parts code: J-6082-393-B)
cannot be used, because it cannot operate
the adjustment remote commander.

[Description on Self-diagnosis Display]

Self-diagnosis display

The camera has a self-diagnosis display. This function displays the camera condition with five-digits (a combination of a letter and figures) on the LCD screen. If this occurs check the following code chart. The five-digits display informs you of the camera's current condition. The last two digits (indicated by □□) will differ depending on the state of the camera.

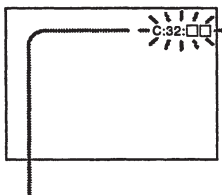

Self-diagnosis display

- C: □□: □□
You can reverse the camera malfunction yourself. (However, contact your Sony dealer or local authorized Sony service facility when you cannot recover from the camera malfunction.)
- E: □□: □□
Contact your Sony dealer or local authorized Sony service facility.

| Display Code | Countermeasure | Cause | Caution Display During Error |
|--------------|--|---|--------------------------------|
| C:04:□□ | Use a NP-FS11/F10 battery pack. | You are using a battery pack that is not an "InfoLITHIUM" battery pack. | for "InfoLITHIUM" BATTERY ONLY |
| C:32:□□ | Turn the power off and on again. | Trouble with hardware. | SYSTEM ERROR |
| C:13:□□ | Format the "Memory stick". | Unformatted memory stick is inserted. | FORMAT ERROR |
| | Insert a new "Memory Stick". | Memory stick is broken. | MEMORY STICK ERROR |
| E:61:□□ | Checking of lens drive circuit. | When failed in the focus and zoom initialization. | — |
| E:91:□□ | Checking of flash unit or replacement of flash unit. | Abnormality when flash is being charged. *1 | |

Note : The error code is cleared if the battery is removed, except defective flash, unit.

*1: When the flash charging failed, Page: D, Address: 67, Data: 04 are written.

After repair, be sure to write Page: D, Address: 67, Data: 00.

SECTION 1 GENERAL

This section is extracted from instruction manual.

WARNING
To prevent fire or shock hazard, do not expose the unit to rain or moisture.

For the Customers in the U.S.A.

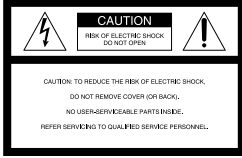

This symbol is intended to alert the user to the presence of uninsulated "dangerous voltage" within the product's enclosure that may be of sufficient magnitude to constitute a risk of electric shock to persons.



This symbol is intended to alert the user to the presence of important operating and maintenance (servicing) instructions in the literature accompanying the appliance.

Never expose the battery pack to temperature above 140°F (60°C), such as in a car parked in the sun or under direct sunlight.

If you have any questions about this product, you may call:
Sony Customer Information Center
1-800-222-SONY (7669)
The number below is for the FCC related matters only.

2

Battery pack

For the Customers in the U.S.A. and Canada

THIS CLASS B DIGITAL DEVICE COMPLIES WITH PART 15 OF THE FCC RULES AND THE CANADIAN ICES-003 OPERATION IS SUBJECT TO THE FOLLOWING TWO CONDITIONS:
(1) THIS DEVICE MAY NOT CAUSE HARMFUL INTERFERENCE, AND
(2) THIS DEVICE MUST ACCEPT ANY INTERFERENCE RECEIVED, INCLUDING INTERFERENCE THAT MAY CAUSE UNDESIRE OPERATION.

Be sure to read the following before using your camera

Trial recording
Before you record one-time events, you may want to make a trial recording to make sure that the camera is working correctly.

No compensation for contents of the recording
Contents of the recording cannot be compensated for if recording or playback is not possible due to a malfunction of your camera, etc.

Notes on image data compatibility
• This camera conforms with the Design Rules for Camera File Systems universal standard established by the JEIDA (Japan Electronic Industries Development Association). You cannot play back on your camera still images recorded on other equipment (DCR-TRV890E/TRV900/TRV900E, DSC-D700, DSC-D770) that does not conform with this universal standard. (These models are not sold in some areas.)
• Playback of images recorded with your camera on other equipment and playback of images recorded or edited with other equipment on your camera are not guaranteed.

4

Regulatory Information

Declaration of Conformity

Trade Name: SONY
Model No.: DSC-P1
Responsible Party: Sony Electronics Inc.
Address: 1 Sony Drive, Park Ridge, NJ, 07656 USA
Telephone No.: 201-930-6972

This device complies with Part 15 of the FCC Rules. Operation is subject to the following two conditions: (1) This device may not cause harmful interference, and (2) this device must accept any interference received, including interference that may cause undesired operation.

CAUTION

You are cautioned that any changes or modifications not expressly approved in this manual could void your authority to operate this equipment.

Note:

This equipment has been tested and found to comply with the limits for a Class B digital device, pursuant to Part 15 of the FCC Rules. These limits are designed to provide reasonable protection against harmful interference in a residential installation. This equipment generates, uses, and can radiate radio frequency energy and, if not installed and used in accordance with the instructions, may cause harmful interference to radio communications. However, there is no guarantee that interference will not occur in a particular installation. If this equipment does cause harmful interference to radio or television reception, which can be determined by turning the equipment off and on, the user is encouraged to try to correct the interference by one or more of the following measures:

- Reorient or relocate the receiving antenna.
- Increase the separation between the equipment and receiver.
- Connect the equipment into an outlet on a circuit different from that to which the receiver is connected.
- Consult the dealer or an experienced radio/TV technician for help.

Precaution on copyright

Television programs, films, video tapes, and other materials may be copyrighted. Unauthorized recording of such materials may be contrary to the provision of the copyright laws.

Do not shake or strike the camera
In addition to malfunctions and inability to record images, this may render the "Memory Stick" unusable or image data breakdown, damage or loss may occur.

Do not aim the camera at the sun or other bright light
This may cause irrecoverable damage to your eyes.

LCD screen, finder (only models with a finder) and lens

- The LCD screen and the finder are manufactured using extremely high-precision technology so over 99.99% of the pixels are operational for effective use. However, there may be some tiny black points and/or bright points (white, red, blue or green in color) that constantly appear on the LCD screen and the finder. These points are normal in the manufacturing process and do not affect the recording in any way.
- Be careful when placing the camera near a window or outdoors. Exposing the LCD screen, the finder or the lens to direct sunlight for long periods may cause malfunctions.

Do not get the camera wet
When taking pictures outdoors in the rain or under similar conditions, be careful not to get the camera wet. If moisture condensation occurs, refer to page 56 and follow the instructions on how to remove it before using the camera.

Back up recommendation
To avoid the potential risk of data loss, always copy (back up) data to a disk.

Handling of the movable lens
This camera uses a movable lens. Be careful not to strike or apply excessive force to the lens portion.

When the camera is used for long periods
Note that the camera body may become hot.

The supplied interface cable must be used with the equipment in order to comply with the limits for a digital device pursuant to Subpart B of Part 15 of FCC Rules.

For the Customers in the U.S.A. and Canada

DISPOSAL OF LITHIUM ION BATTERY.

LITHIUM ION BATTERY. DISPOSE OF PROPERLY.

You can return your unwanted lithium ion batteries to your nearest Sony Service Center or Factory Service Center.

Note:

In some areas the disposal of lithium ion batteries in household or business trash may be prohibited.

For the Sony Service Center nearest you call 1-800-222-SONY (United States only)
For the Sony Factory Service Center nearest you call 416-499-SONY (Canada only)

Caution:

Do not handle damaged or leaking lithium ion battery.

CAUTION

TO PREVENT ELECTRIC SHOCK, DO NOT USE THIS POLARIZED AC PLUG WITH AN EXTENSION CORD, RECEPTACLE OR OTHER OUTLET UNLESS THE BLADES CAN BE FULLY INSERTED TO PREVENT BLADE EXPOSURE.

Attention for the Customers in Europe

This product has been tested and found compliant with the limits sets out on the EMC Directive for using connection cables shorter than 3 meters.

The electromagnetic fields at the specific frequencies may influence the picture and sound of this camera.

NOTICE FOR THE CUSTOMERS IN THE UNITED KINGDOM

A moulded plug complying with BS 1363 is fitted to this equipment for your safety and convenience.

Should the fuse in the plug supplied need to be replaced, a 5 AMP fuse approved by ASTA or BSI to BS 1362, (i.e. marked with Ⓢ or Ⓡ mark) must be used.

If the plug supplied with this equipment has a detachable fuse cover, be sure to attach the fuse cover after you change the fuse. Never use the plug without the fuse cover. If you should lose the fuse cover, please contact your nearest Sony service station.

For the Customers in Germany

Directive: EMC Directive 89/336/EEC.92/31/EEC

This equipment complies with the EMC regulations when used under the following circumstances:

- Residential area
 - Business district
 - Light-industry district
- (This equipment complies with the EMC standard regulations EN55022 Class B.)

"Memory Stick"



For the Customers in CANADA

This Class B digital apparatus complies with Canadian ICES-003.

"Memory Stick" and Battery Pack

For the Customers in the U.S.A.

This device complies with Part 15 of the FCC Rules. Operation is subject to the following two conditions: (1) This device may not cause harmful interference, and (2) this device must accept any interference received, including interference that may cause undesired operation.

3

Getting started

Identifying the parts

See the pages in parentheses for details of operation.

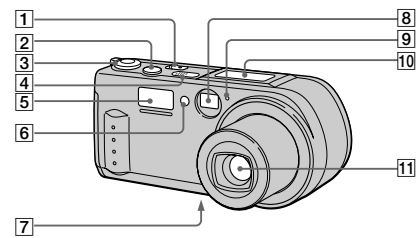

- 1 POWER switch/lamp
- 2 Shutter button (15) (21)
- 3 MODE selector (32)
- 4 Built-in microphone
Do not touch while recording.
- 5 Flash (20)
- 6 Photocell window for flash
Do not block while recording.

- 7 Tripod receptacle (bottom surface)
Use a tripod with a screw length of less than 9/32 inch (6.5 mm). You will be unable to firmly secure the camera to tripods having longer screws, and may damage the camera.
- 8 Finder window
- 9 Self-timer/recording lamp (only during recording moving images)
- 10 Display window
- 11 Lens

6

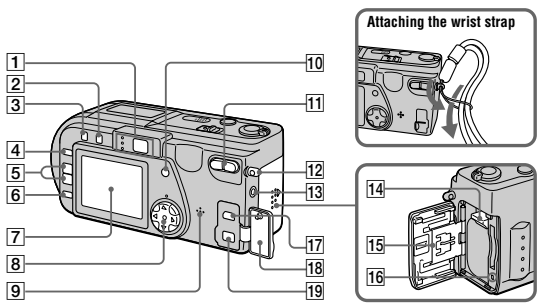

- 1 **Finder**
Self-timer/recording lamp (red)
AE lock lamp (green)
Strobe charge lamp (orange)
- 2 **⚡ (flash) button**
- 3 **⬇ (MACRO) button (43)**
- 4 **PROGRAM AE button (43)**
- 5 **VOLUME +/- button**
- 6 **LCD ON/OFF button**
Set to OFF to save the battery when using the finder.
- 7 **LCD screen**
- 8 **Control button**
- 9 **Speaker**
- 10 **DISPLAY button**
- 11 **Zoom button**
- 12 **Hook for wrist strap**
- 13 **A/V OUT jack (50)**
Audio output is monaural.
- 14 **Battery eject lever (8)**
- 15 **Battery/"Memory Stick" cover**
- 16 **Access lamp (14)**
- 17 **USB jack (mini-B) (26) (27)**
- 18 **Jack cover**
- 19 **DC IN jack (9) (11)**

Getting started

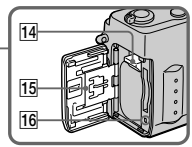

Preparing the power supply

Installing the battery pack

Your camera operates only with the "InfoLITHIUM" NP-FS11 battery pack* (S series). You cannot use any other battery pack.

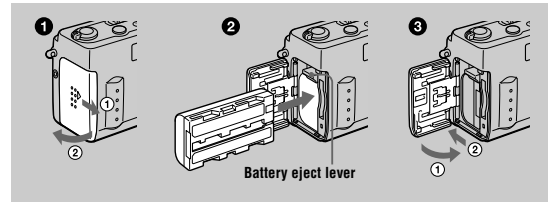

- 1 **Open the battery/"Memory Stick" cover.**
Slide the cover in the direction of the arrow.
- 2 **Install the battery pack.**
Insert the battery pack with the ► mark facing toward the battery compartment as illustrated.
- 3 **Close the battery/"Memory Stick" cover.**

To remove the battery pack

Open the battery/"Memory Stick" cover. Slide the battery eject lever upward, and remove the battery pack. Be careful not to drop the battery pack when removing it.

* What is "InfoLITHIUM"?

"InfoLITHIUM" is a lithium ion battery pack which can exchange information such as battery consumption with compatible video equipment. This unit is compatible with the "InfoLITHIUM" battery pack (S series). "InfoLITHIUM" S series battery packs have the mark. "InfoLITHIUM" is a trademark of Sony Corporation.

7

Charging the battery pack

You cannot charge the battery pack while your camera is turned on. Be sure to turn off your camera before charging.

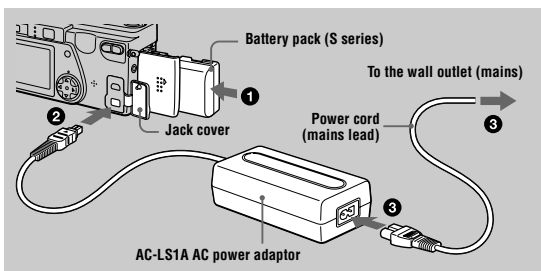

- 1 **Insert the battery pack into your camera.**
- 2 **Open the jack cover and connect the DC connecting cable to the DC IN jack of your camera with the ▲ mark facing up.**
- 3 **Connect the power cord (mains lead) to the AC power adaptor and then to a wall outlet (mains).**
The battery indicator in the display window flashes when charging begins. When the battery indicator stops flashing, **normal charge** is completed. For **full charge**, which allows you to use the battery longer than usual, leave the battery pack inserted for about one hour after normal charge is completed until the battery remaining indicator and "FULL" is displayed alternately in the display window.

After charging

Remove the AC power adaptor.

Battery remaining indicator

The LCD screen on the camera shows the remaining time for which you can still record or play back images. This indication may not be entirely accurate depending on the conditions of use and the operating environment. Charging at a room temperature of 50°F to 86°F (10°C to 30°C) is recommended.

9

8

NP-FS11 battery pack

When you record images in an extremely cold location or using the LCD screen, the operating time becomes short. When using the camera in an extremely cold location, place the battery pack in your pocket or other place to keep it warm, then insert the battery pack into the camera just before recording. When using a pocket heater, take care not to let the heater directly contact the battery.

Charging time

| Battery pack | Full charge (min.) | Normal charge (min.) |
|--------------------|--------------------|----------------------|
| NP-FS11 (supplied) | 180 | 130 |

Approximate time to charge a completely discharged battery pack using the AC-LS1A AC power adaptor.

Battery life and number of images that can be recorded/played back

STILL mode recording*

| | NP-FS11 (supplied) | |
|----------------|---------------------|------------------|
| | Battery life (min.) | Number of images |
| LCD screen ON | 70 (65) | 1300 (1200) |
| LCD screen OFF | 90 (85) | 1700 (1600) |

STILL mode playback**

| | NP-FS11 (supplied) | |
|---------------|---------------------|------------------|
| | Battery life (min.) | Number of images |
| LCD screen ON | 105 (100) | 2000 (1900) |

Approximate battery life and number of images that can be recorded/played back with a fully charged battery pack at a temperature of 77°F (25°C), 640×480 image size and in NORMAL recording mode. Numbers in parentheses indicate the time when you use a normally charged battery pack.

* Recording at about 4-second intervals

** Playing back single images in order at about 3-second intervals

MOVIE mode recording

| | NP-FS11 (supplied) | |
|----------------------|-----------------------|----------------------|
| | LCD screen OFF (min.) | LCD screen ON (min.) |
| Continuous recording | 110 (100) | 85 (75) |

Approximate time that can be recorded with a fully charged battery pack at a temperature of 77°F (25°C) and 160×112 image size. Numbers in parentheses indicate the time when you use a normally charged battery pack.

10

Notes

- The battery life and number of images will be decreased if you use your camera at low temperatures, use the flash, repeatedly turn the power on/off or use the zoom.
- The capacity of the "Memory Stick" is limited. The figures in the table are a guide when you continuously record/play back while replacing the "Memory Stick."
- "----" appears in the display window until the battery usable time is calculated.
- During charging, the indicators in the display window may not appear correctly or may flash in the following cases.
 - When the battery pack is not installed correctly.
 - When the battery pack has malfunctioned.
- When you turn the LCD screen on and off, it takes about one minute for the correct battery remaining time to appear.
- If the power may go off although the battery remaining indicator indicates that the battery pack has enough power to operate, charge the battery pack fully again so that the indication on the battery remaining indicator is correct.
- Use the AC power adaptor near the wall outlet (mains). If any trouble occurs while using the camera, immediately unplug the power cord from the wall outlet (mains) to cut off the power.
- Do not short the DC plug of the AC power adaptor with a metallic object, as this may cause malfunction.
- Do not expose the battery pack to water.
- When the battery pack will not be used for a long time, charge the battery pack once fully, and use it in PLAY mode until it completely discharges. Keep the battery pack in a cool place.
- Battery life will be shorter when you record with the LCD screen ON. We recommend that you turn the LCD screen OFF.

Using the AC power adaptor

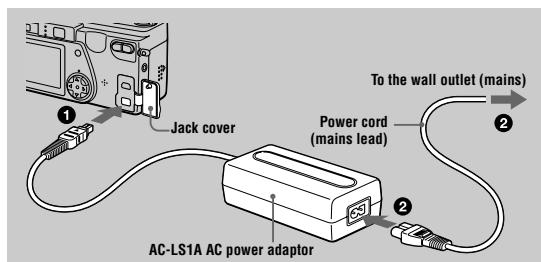

- 1 Open the jack cover and connect the DC connecting cable to the DC IN jack of your camera with the ▲ mark facing up.
- 2 Connect the power cord (mains lead) to the AC power adaptor and then to a wall outlet (mains).

Getting started

11

- 4 Select [CLOCK SET] with ▲/▼ on the control button, then press the center ●.

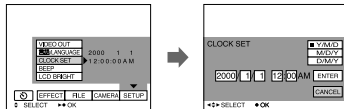

- 5 Select the desired date display format with ▲/▼ on the control button, then press the center ●. Select from [Y/M/D] (year/month/day), [M/D/Y] (month/day/year) or [D/M/Y] (day/month/year).

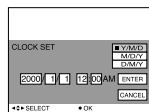

- 6 Select the year, month, day, hour or minute item you want to set with ◀/▶ on the control button. The item to be set is indicated with ▲/▼.

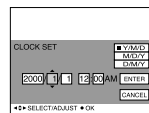

- 7 Set the numeric value with ▲/▼ on the control button, then press the center ● to enter it. After entering the number, ▲/▼ moves to the next item. If you selected [D/M/Y] in step 5, set the time on a 24-hour cycle.

- 8 Select [ENTER] with ▶ on the control button, then press the center ● at the desired moment to begin clock movement. The date and time are entered.

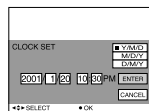

To cancel the date and time setting

Select [CANCEL] with ▲/▼/◀/▶ on the control button, then press the center ●.

Auto power-off function

If you do not operate the camera for about three minutes during recording, the camera turns off automatically to prevent wearing down the battery. To use the camera again, slide the POWER switch to turn on the camera again.

Getting started

13

Setting the date and time

When you first use your camera, set the date and time. If these are not set, the CLOCK SET screen appears whenever you turn on your camera for recording.

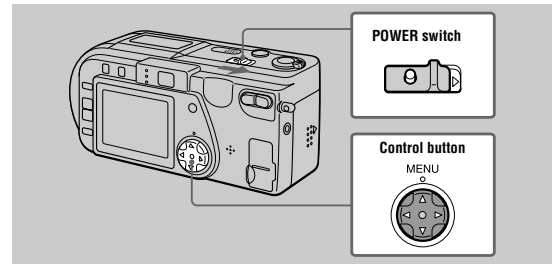

- 1 Slide the POWER switch to turn on the power. The POWER lamp lights up.
- 2 Press ▲ on the control button. The menu bar appears on the LCD screen.
- 3 Select [SETUP] with ▶ on the control button, then press the center ●.

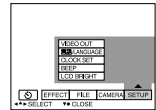
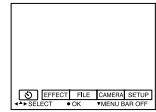

12

Inserting the "Memory Stick"

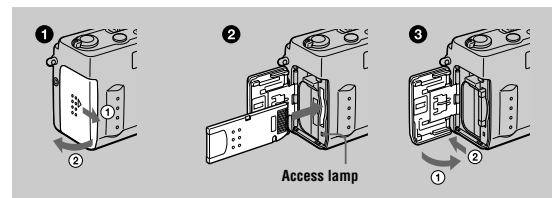

- 1 Open the battery/"Memory Stick" cover. Slide the cover in the direction of the arrow.
- 2 Insert the "Memory Stick." Insert the "Memory Stick" with the ▶ mark facing toward the battery compartment as illustrated until it clicks.
- 3 Close the battery/"Memory Stick" cover.

Removing the "Memory Stick"

Open the battery/"Memory Stick" cover, then press the "Memory Stick" once lightly.

Notes

- If you do not insert the "Memory Stick" firmly until it clicks, a message such as "MEMORY STICK ERROR" will be displayed.
- Never remove the "Memory Stick" or turn off the power while the access lamp is lit up.
- You cannot record or edit images on a "Memory Stick" if the erasure prevention switch is set to the LOCK position.

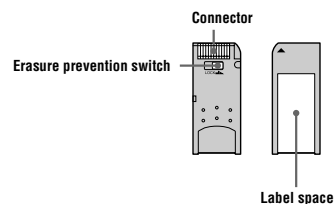

14

Recording still images

Still images are recorded in JPEG format.

To record still images, slide the POWER switch to turn on the power and insert a "Memory Stick."

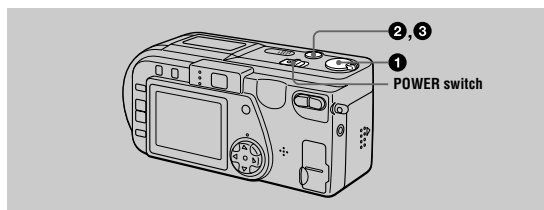

▶ Recording

1 Set the MODE selector to STILL.

2 Press and hold the shutter button halfway down and check the image.

While the AE lock indicator ● (green) is flashing rapidly, the image freezes momentarily, but is not yet recorded. When the camera finishes the automatic adjustments*, the AE lock indicator ● stops flashing rapidly and lights up.** The camera is ready for recording. To cancel the recording, release the shutter button.

Remaining memory capacity indicator

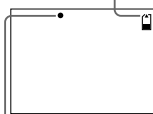

AE lock indicator

3 Press the shutter button fully down.

The shutter sounds and the image is recorded on the "Memory Stick." When "RECORDING" disappears, you can record the next image.

* Exposure and focus are automatically adjusted.

** When the AE lock indicator ● changes to flashing slowly, the subject may be difficult to focus on (dark or no contrast) or the subject may be extremely close. Release the shutter and focus again, and be sure to check the picture after recording.

If you skip step 2 and press the shutter fully down

The shutter sounds and the image is recorded on the "Memory Stick".

You cannot record an image when:

- The recording conditions require a flash and the strobe charge lamp (page 17) is flashing.

15

Recording images with the finder

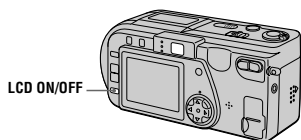

Press LCD ON/OFF to turn off the LCD screen.

Indicators on the finder

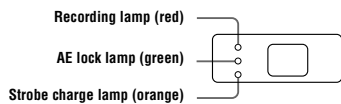

Notes

- When recording a subject closer than 3 1/4 feet (1 m), record using the LCD screen. When recording images with the finder, the positions of the finder and the lens differ, so the recording range may be slightly offset.
- You cannot turn off the LCD screen when [DEMO] is set to [ON] in the menu settings.

Checking the last recorded image (Quick Review)

You can check the last recorded image by clearing the menu bar from the screen (page 33) and pressing ◀ on the control button. To return to the normal recording mode, press lightly on the shutter button or select [RETURN] with ▶ on the control button and then press the center ●. You can also delete the image first by selecting [DELETE] on the Quick Review screen with ◀▶ on the control button and pressing the center ●, and then selecting [OK] with ▲▼ on the control button and pressing the center ●.

17

The number of images you can record on a "Memory Stick"

See pages 39 to 42.

Notes

- Do not touch the lens portion while it is operating.
- While the image is being recorded on the "Memory Stick," do not shake or strike the camera. Also, do not turn the power off, or remove the battery pack or "Memory Stick."
- When recording a bright subject, the LCD screen color may change after AE lock, but this does not affect the recorded image.

Holding the camera correctly

Hold the camera so that your fingers do not block the flash when recording images.



16

Using the zoom feature

The lens portion moves during zoom operation. Be careful not to touch the lens portion while it is operating.

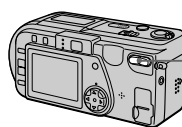

Zoom button
W side: for wide-angle (subject appears farther away)



T side: for telephoto (subject appears closer)

Minimum focal distance to the subject

W side: About 19 3/4 inches (50 cm) or more
T side: About 19 3/4 inches (50 cm) or more
To record even closer subjects, see page 43.

Digital zoom function

This camera has a digital zoom function.

Digital zoom enlarges the image by digital processing and it starts to function when zoom exceeds 3x.

The T side of the bar shows the digital zooming zone.

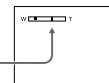

Using digital zoom

- The maximum zoom magnification is 6x.
- Digital zooming deteriorates the picture quality. When digital zoom is not necessary, set [DIGITAL ZOOM] to [OFF] in the menu settings (page 37).

Notes

- Zoom does not work while recording moving images.
- Digital zoom does not work for moving images.
- Digitally zoomed images do not appear in the finder. Check these images using the LCD screen.

18

LCD screen indicators during recording

Press DISPLAY to turn on/off the indicators on the LCD screen. See page 67 for a detailed description of the indicated items.

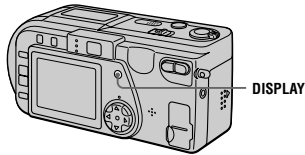

Notes

- You cannot turn off the self-timer indicators and some of the indicators used in advanced operations.
- The indicators on the LCD screen are not recorded.

Using the self-timer

When you use the self-timer function, the subject is recorded about 10 seconds after you press the shutter button.

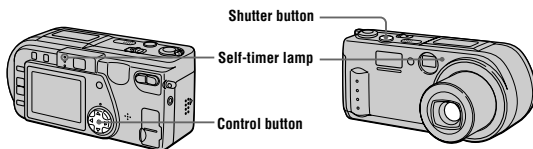

Select (self-timer) indicator on the menu bar with on the control button, then press the center . The (self-timer) indicator appears on the LCD screen, and about 10 seconds after you press the shutter button, the subject is recorded. The self-timer lamp flashes after you press the shutter button until the shutter is released.

▶ Recording

19

Recording moving images

Moving images with audio are recorded in MPEG format. To record moving images, slide the POWER switch to turn on the power and insert a "Memory Stick."

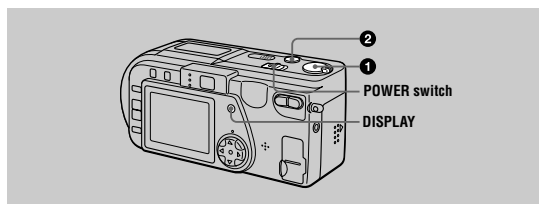

▶ Recording

1 Set the MODE selector to MOVIE.

2 Press the shutter button fully down.

"REC" appears on the LCD screen, and the image and sound are recorded on the "Memory Stick."

If you press the shutter button once

The image and sound are recorded for five seconds. You can change the recording time to 10 or 15 seconds with [REC TIME SET] in the menu settings (page 36).

If you hold the shutter button down

The image and sound are recorded while the shutter button is held down for up to 60 seconds. However, when [IMAGE SIZE] in the menu setting is set to [320 (HQ)]/[320×240], the maximum recording time is 15 seconds (page 36).

Zooming or using the self-timer, etc.

See pages 18 and 19.

LCD screen indicators during recording

Press DISPLAY to turn on/off the indicators on the LCD screen. These indicators are not recorded. See page 67 for a detailed description of the indicators.

21

Recording images with the flash

The initial setting is auto (no indicator). In this mode, the flash automatically strobes when the surroundings become dark. When you change the flash mode, press the (flash) repeatedly so that the flash mode indicator appears on the LCD screen.

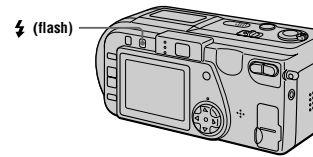

Each time you press the (flash), the indicator changes as follows. (No indicator) → → → → (No indicator)

Auto red-eye reduction: The flash strobes before recording to reduce the red-eye phenomenon.

Forced flash: The flash strobes regardless of the surrounding brightness.

No flash: The flash does not strobe.

You can change the brightness of the flash (FLASH LEVEL) in the menu settings (page 37).

Notes

- The recommended shooting distance using the built-in flash is 1 5/8 feet to 7 1/2 feet (0.5 m to 2.3 m) when set to the W side, or 1 5/8 feet to 3 7/8 feet (0.5 m to 1.2 m) when set to the T side.
- Auto red-eye reduction may not produce the desired red-eye reduction effects depending on individual differences, the distance to the subject, if the subject does not see the pre-strobe, or other conditions.
- The flash effect is not obtained easily when you use forced flash in a bright location.
- When you record images in a dark place with the camera set to (no flash), the shutter speed becomes slow, so using a tripod is recommended to prevent shaking.

20

▶ Playback

Playing back still images

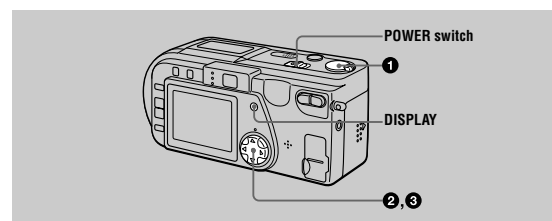

1 Set the MODE selector to PLAY.

The last recorded image (still or moving) appears on the LCD screen.

2 Press on the control button to display the menu bar on the LCD screen.

3 Select the desired still image with the control button.

Press on the control button to select on the LCD screen, then press on the control button.

: To display the preceding image.

: To display the next image.

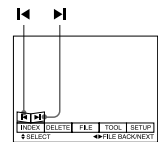

When the menu bar is not displayed

You can directly select and play back the image with on the control button.

Notes

- You might not be able to correctly play back images recorded with this camera on other equipment.
- You cannot play back on this camera images larger than the maximum image size that can be recorded with this camera.

LCD screen indicators during still image playback

Press DISPLAY to turn on/off the indicators on the LCD screen. See page 68 for a detailed description of the indicators.

22

Playing back moving images

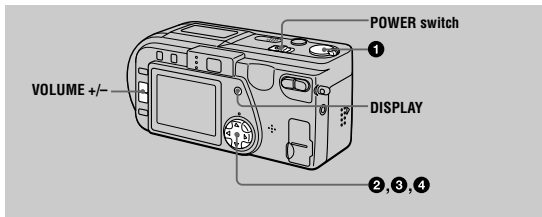

- 1 Set the MODE selector to PLAY.**
The last recorded image (still or moving) appears on the LCD screen.
- 2 Press ▲ on the control button to display the menu bar on the LCD screen.**
- 3 Select the desired moving image with the control button.**
Moving images are displayed one-size smaller than still images.
Press ▲▼/◀▶ on the control button to select ◀▶ on the LCD screen, then press ◀▶ on the control button.
◀: To display the preceding image.
▶: To display the next image.
- 4 Select ▶ (playback) on the LCD screen with ▲▼/◀▶ on the control button, then press the center ●.**
The moving image and sound are played back. During playback, ▶ (playback) changes to II (pause).

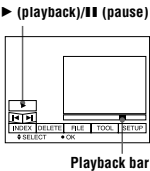
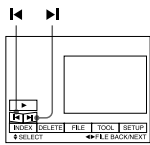

▶ Playback

To pause playback

Select II (pause) on the LCD screen with ▲▼/◀▶ on the control button, then press the center ●.

23

Viewing images using a personal computer

You can view data recorded with your camera on a personal computer and attach it to e-mail. This section describes the method for installing the USB driver and viewing images on a personal computer. Be sure to also see the operation manuals for your personal computer and application software.

Note

Data recorded with your camera is stored in the following formats. Make sure that applications that support these file formats are installed on your personal computer.

- Still images (other than TEXT mode, uncompressed mode and Clip Motion): JPEG format
- Moving images/audio: MPEG format
- Uncompressed mode still images: TIFF format
- TEXT mode, Clip Motion: GIF format

Recommended computer environment

Recommended Windows environment

OS: Microsoft Windows 98, Windows 98SE, Windows 2000 Professional
Standard installation is required.

Operation is not assured in an environment upgraded from:

- Windows 3.1, Windows 95 to Windows 98 or Windows 98 to Windows 98SE;
- Windows NT 3.51, Windows NT 4.0, Windows 98, Windows 98SE, Windows 95 to Windows 2000

CPU: MMX Pentium 200 MHz or faster

The USB connector must be provided as standard.

ActiveMovie Player (DirectShow) must be installed (to play back moving pictures).

Recommended Macintosh environment

Macintosh computer with the Mac OS 8.5.1/8.6/9.0 standard installation

However, note that the update to Mac OS 9.0 should be used for the following models.

- iMac with the Mac OS 8.6 standard installation and a slot loading type CD-ROM drive
- iBook or G4 with the Mac OS 8.6 standard installation

The USB connector must be provided as standard.

QuickTime 3.2 or newer must be installed (to play back moving pictures).

Notes

- Operations are not guaranteed for either the Windows or Macintosh environment if you connect two or more USB equipment to a single personal computer at the same time (except for the USB keyboard and mouse which are provided as standard), or when using a hub.
- Depending on the type of USB equipment that is used simultaneously, some equipment may not operate.
- Operations are not guaranteed for all the recommended computer environments mentioned above.

▶ Playback

25

When the menu bar is not displayed

You can directly select the image with ◀▶ on the control button, and play back the image and sound by pressing the center ●. When you press the center ● during playback, playback is paused.

Moving images recorded with the image of [320 (HQ)]

The images are displayed over the entire screen in steps 3 and 4.

Adjusting the volume

Press VOLUME +/- to adjust the volume.

LCD screen indicators during moving image playback

Press DISPLAY to turn on/off the indicators on the LCD screen.

See page 68 for a detailed description of the indicators.

24

Installing the USB driver

Before connecting your camera to your personal computer, install the USB driver to the computer. The USB driver is contained together with application software for viewing images on a CD-ROM which is supplied with your camera.

For Windows 98, Windows 98SE and Windows 2000 users

- 1 Turn on your personal computer and allow Windows to load.**
- 2 Insert the supplied CD-ROM in the CD-ROM drive of your personal computer.**
The application software screen appears.
- 3 Click "USB Driver Installation for Windows 98/98SE, Windows 2000".**
USB driver installation starts.
- 4 Follow the on-screen messages to install the USB driver.**
- 5 Connect the USB jack (mini-B) on your camera with the USB connector on your personal computer using the supplied USB cable.**

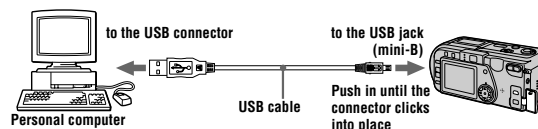

- 6 Insert a "Memory Stick" into your camera, connect the AC power adaptor and turn on your camera.**
"PC MODE" appears on the LCD screen of your camera and the camera is set to communication standby mode. Your personal computer recognizes the camera, and the Windows Add Hardware Wizard starts.
- 7 Follow the on-screen messages to have the Add Hardware Wizard recognize the hardware.**
The Add Hardware Wizard starts twice because two different USB drivers are installed. Be sure to allow the installation to complete without interrupting it.

Note

In step 7, make sure that a "Memory Stick" is inserted in your camera. Otherwise, you will be unable to install the USB driver.

26

For Macintosh users

- 1 Turn on your personal computer and allow the Mac OS to load.
- 2 Insert the supplied CD-ROM in the CD-ROM drive of your personal computer.
- 3 Double-click the CD-ROM drive icon to open the window.
- 4 Double-click the icon of the hard disk containing the OS to open the window.
- 5 Move the following two files from the window opened in step 3 to the "System Folder" icon in the window opened in step 4 (drag and drop).
 - Sony USB Driver
 - Sony USB Shim
- 6 When "Put these items into the Extensions folder?" appears, click "OK."
- 7 Restart your personal computer.

Viewing images

For Windows 98, Windows 98SE and Windows 2000 users

- 1 Turn on the power of your personal computer and allow Windows to load.
- 2 Connect one end of the USB cable to the USB jack (mini-B) on the camera and the other end to the USB connector on your personal computer.

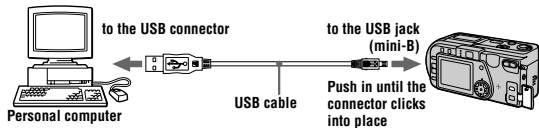

- 3 Insert a "Memory Stick" into your camera, and connect the AC power adaptor to your camera and then to a wall outlet (mains).

▶ Playback

Notes on using your personal computer

"Memory Stick"

- "Memory Stick" operations on your camera cannot be assured if the "Memory Stick" has been formatted on your personal computer.
- Do not optimize the "Memory Stick" on a Windows machine. This will shorten the "Memory Stick" life.
- Do not compress the data on the "Memory Stick." Compressed files cannot be played back on your camera.

Software

- Depending on your application software, the file size may increase when you open a still image file.
- When you load an image modified using the supplied retouch software from your personal computer to the camera or when you directly modify the image on the camera, the image format will differ so the "FILE ERROR" message may appear and you may be unable to open the file.
- Depending on your application software, only the first frame of a Clip Motion image may be displayed.

Communications with your personal computer

Communications between your camera and your personal computer may not recover after recovering from Suspend, Resume, or Sleep.

Other

When connecting the camera to a personal computer or when using an external power source, remove the battery pack from inside the camera.

- Windows and ActiveMovie, DirectShow are either registered trademarks or trademarks of Microsoft Corporation in the United States and/or other countries.
- Macintosh and Mac OS, QuickTime are trademarks of Apple Computer, Inc.
- All other product names mentioned herein may be the trademarks or registered trademarks of their respective companies. Furthermore, "TM" and "®" are not mentioned in each case in this manual.

▶ Playback

- 4 Turn on the power of your camera. "PC MODE" appears on the LCD screen of the camera.

- 5 Open "My Computer" on Windows and double click the newly recognized drive. (Example: "Removable Disk (D:)")
The folders inside the "Memory Stick" are displayed.

- 6 Select and double-click the desired image/sound file from the folder.

For the detailed folder and file name, see "Image file storage destinations and image files" (page 30).

| Desired file type | Double-click in this order |
|--|---|
| Still image | "Dcim" folder → "100msdcf" folder → Image file |
| Moving image* | "Mssony" folder → "Moml0001" folder → Image file* |
| Audio* | "Mssony" folder → "Momlv100" folder → Audio file* |
| Clip Motion image | "Dcim" folder → "100msdcf" folder → Image file |
| E-mail image TIFF image (uncompressed) | "Mssony" folder → "Imcif100" folder → Image file |

* Copying a file to the hard disk of your personal computer before viewing it is recommended. If you play back the file directly from the "Memory Stick", the image and sound may break off.

For Windows 2000 users

When using Windows 2000, the following procedures are recommended when disconnecting the USB cable from your personal computer or ejecting the "Memory Stick" from the camera while it is connected to your personal computer.

- 1 Stop the drive by clicking on the "Unplug/Eject" icon in the task tray.
- 2 When the message appears confirming the safe removal of the hardware, disconnect the USB cable or eject the "Memory Stick".

Image file storage destinations and image files

Image files recorded with your camera are grouped in folders by recording mode. The meanings of the file names are as follows. □□□□ stands for any number within the range from 0001 to 9999.

For Windows 98 users (The drive recognizing the camera is "D.")

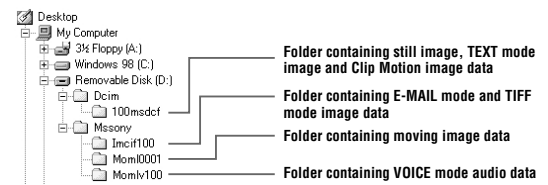

| Folder | File | Meaning |
|----------|--------------|---|
| 100msdcf | DSC0□□□□.JPG | • Still image file recorded normally • Still image file recorded in E-MAIL mode (page 41) • Still image file recorded in TIFF mode (page 42) • Still image file recorded in VOICE mode (page 41) |
| | CLP0□□□□.GIF | • Clip Motion file recorded in NORMAL mode (page 40) |
| | CLP0□□□□.THM | • Index image file of Clip Motion file recorded in NORMAL mode |
| | MBL0□□□□.GIF | • Clip Motion file recorded in MOBILE mode (page 40) |
| | MBL0□□□□.THM | • Index image file of Clip Motion file recorded in MOBILE mode |
| | TXT0□□□□.GIF | • Still image file recorded in TEXT mode (page 42) |
| | TXT0□□□□.THM | • Index image file of still image file recorded in TEXT mode |

| Folder | File | Meaning |
|----------|--------------|---|
| Imcif100 | DSC0□□□□.JPG | • Small-size image file recorded in E-MAIL mode (page 41) |
| | DSC0□□□□.TIF | • Uncompressed image file recorded in TIFF mode (page 42) |
| Moml0001 | MOV0□□□□.MPG | • Moving image file recorded normally |
| Momlv100 | DSC0□□□□.MPG | • Audio file recorded in VOICE mode (page 41) |

The numerical portions of the following files are the same.

- A small-size image file recorded in E-MAIL mode and its corresponding image file
- An uncompressed image file recorded in TIFF mode and its corresponding image file
- An audio file recorded in VOICE mode and its corresponding image file
- An image file recorded in TEXT mode and its corresponding index image file
- An image file recorded with CLIP MOTION and its corresponding index image file

▶ Playback

Advanced operations

Before performing advanced operations

This section describes the basic control methods that are frequently used for “Advanced operations”.

How to use the MODE selector

The MODE selector selects whether you can use your camera to record or to play back and edit images. Set the selector as follows before starting to operate your camera.

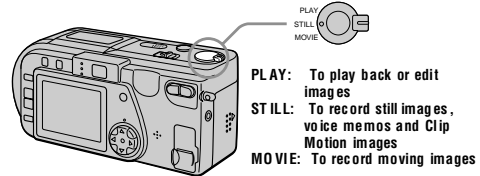

How to use the control button

The control button is used to select the indicators, images and menus appearing on the LCD screen of your camera. The operation methods that are frequently used for “Advanced operations” are described below.

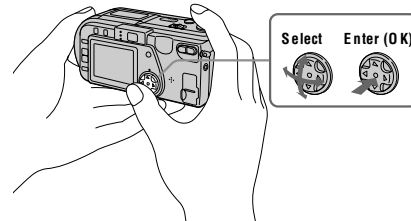

31

32

Turning on/off the operation buttons (menu bar) on the LCD screen

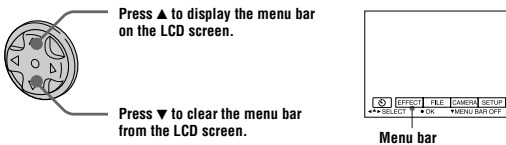

Note
 You cannot clear the menu bar during INDEX screen display (page 47).

Selecting items and images on the LCD screen

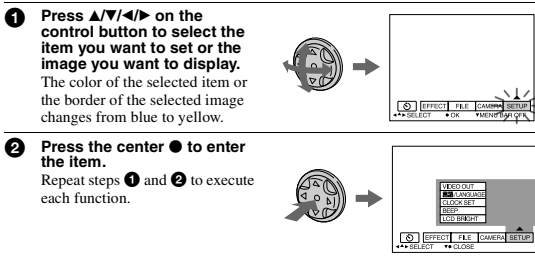

The “Advanced operations” section of this manual refers to selecting and entering items by the above procedure as “Select [(item name)].”

33

Before performing advanced operations

How to change the menu settings

Some of the advanced operations for your camera are executed by selecting menu items displayed on the LCD screen with the control button.

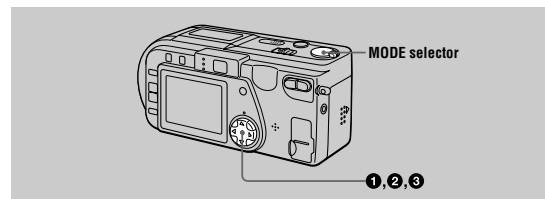

- Press ▲ on the control button to display the menu bar. The menu bar appears as follows according to the setting of the MODE selector.

| MOVIE/STILL | PLAY (single mode) | PLAY (INDEX mode) |
|-------------|--------------------|-------------------|
| | | |
- Select the desired item with ▲/▼/◀/▶ on the control button, then press the center ●. The color of the selected item changes from blue to yellow, and when you press the center ●, the modes that can be set for that item are displayed.

| |
|--|
| |
|--|
- Select the desired mode with ▲/▼/◀/▶ on the control button, then press the center ●.

To clear the menu

Press ▼ on the control button until the LCD screen returns to the menu bar display in step 1. To clear the menu bar, press ▼ again.

34

Menu settings

Menu items that can be modified differ depending on the setting of the MODE selector. The LCD screen shows only the items you can operate at the moment. Initial settings are indicated with ■.

⏸ (SELF TIMER)

Records with the self-timer (page 19).

EFFECT

| Item | Setting | Description | MODE selector |
|-----------|--|--|----------------|
| PEFFECT | SOLARIZE B&W SEPIA NEG.ART ■ OFF | Sets the image special effects (page 46). | MOVIE STILL |
| DATE/TIME | DAY&TIME DATE ■ OFF | Sets whether to insert the date and time into the image (page 45). | STILL |

FILE

| Item | Setting | Description | MODE selector |
|-------------|--|--|------------------------|
| FORMAT | OK CANCEL | Formats a "Memory Stick." Cancels formatting of a "Memory Stick." | MOVIE STILL PLAY |
| FILE NUMBER | SERIES ■ NORMAL | Assigns numbers to files in sequence even if the "Memory Stick" is changed. Resets the file numbering each time the "Memory Stick" is changed. | MOVIE STILL |
| CLIP MOTION | 160x120 (NORMAL) 80x72 (MOBILE) CANCEL | Sets the image size and number of frames for creating GIF format animation (page 40). Up to 10 frames can be recorded. Up to 2 frames can be recorded. Cancels Clip Motion. | STILL |

35

CAMERA

| Item | Setting | Description | MODE selector |
|---------------|---|--|----------------|
| DIGITAL ZOOM | ■ ON OFF | Uses digital zoom. Does not use digital zoom. | STILL |
| SHARPNESS | +2 to -2 [] appears on the LCD screen except when set to 0. | Adjusts the sharpness of the image. | STILL |
| WHITE BALANCE | IN DOOR OUT DOOR HOLD ■ AUTO | Sets the white balance (page 45). | MOVIE STILL |
| FLASH LEVEL | HIGH ■ NORMAL LOW | Makes the flash level higher than normal. Normal setting. Makes the flash level lower than normal. | STILL |
| EXPOSURE | +2.0 EV to -2.0 EV | Adjusts the exposure. | MOVIE STILL |

TOOL

| Item | Setting | Description | MODE selector |
|------------------------------|---|---|---------------|
| COPY | OK CANCEL | Copies an image (page 53). Cancels copying of the image. | PLAY |
| RESIZE (in single mode only) | 2048x1536 1600x1200 1280x960 640x480 CANCEL | Changes the recorded still image size (page 53). | PLAY |

SETUP

| Item | Setting | Description | MODE selector |
|------|------------------|---|----------------|
| DEMO | ■ ON/STBY OFF | Displayed only when you use the AC power adaptor in MOVIE or STILL mode. When ON is selected, a demonstration will start if you do not operate your camera for about 10 minutes. To stop the demonstration, turn off your camera. Select ON to make the demonstration appear again. | MOVIE STILL |

37

| Item | Setting | Description | MODE selector |
|----------------------------------|---|--|---------------|
| IMAGE SIZE | ■ 2048x1536 2048 (3:2) 1600x1200 1280x960 640x480 | Selects the image size when recording still images. | STILL |
| | 320 (HQ) 320x240 ■ 160x112 | Selects the MPEG image size when recording moving images. | MOVIE |
| REC MODE | TIFF | Records a TIFF (uncompressed) file in addition to the JPEG file. | STILL |
| | TEXT | Records a GIF file in black-and-white. | |
| | VOICE | Records an audio file (with still image) in addition to the JPEG file. | |
| | E-MAIL | Records a small-size (320x240) JPEG file in addition to the selected image size. | |
| | ■ NORMAL | Records a JPEG file in the selected image size. | |
| REC TIME SET | 15 sec 10 sec ■ 5 sec | Adjusts the recording time for moving images. | MOVIE |
| ROTATE (in single mode only) | — | Rotates the still image. | PLAY |
| SLIDE SHOW (in single mode only) | INTERVAL | Sets the slide show interval. ■ 3 sec/5 sec/10 sec/30 sec/1 min | PLAY |
| | REPEAT | Repeats the slide show. ■ ON/OFF | |
| | START | Starts the slide show. | |
| | CANCEL | Cancels the slide show settings and execution. | |
| PRINT MARK | ON | Marks the still images to be printed (page 55). | PLAY |
| | ■ OFF | Unmarks the print mark of the still images. | |
| PROTECT | ON | Protects images against accidental erasure (page 51). | PLAY |
| | ■ OFF | Releases protection of images against accidental erasure. | |

36

| Item | Setting | Description | MODE selector |
|-----------------|----------------------|---|------------------------|
| VIDEO OUT | NTSC | Sets the video output signal to NTSC mode (North American countries, Japan, etc.). | MOVIE STILL PLAY |
| | PAL | Sets the video output signal to PAL mode (European countries, etc.). | |
| 言語/ LANGUAGE | ■ ENGLISH 日本語/JPN | Displays the menu items in English. Displays the menu items in Japanese. | MOVIE STILL PLAY |
| CLOCK SET | — | Sets the date and time (page 12). | MOVIE STILL PLAY |
| BEEP | SHUTTER | Turns off the beep only. (The shutter sound is heard when you press the shutter button.) | MOVIE STILL PLAY |
| | ■ ON | Turns on the beep/shutter sound (when you press the control button/shutter button). | |
| | OFF | Turns off the beep/shutter sound. | |
| LCD BRIGHT | ■■■■■■■■■■ | Adjusts the LCD screen brightness using the +/- buttons on the LCD screen. This has no effect on the recorded images. | MOVIE STILL PLAY |

INDEX*

Displays six images at a time (PLAY (INDEX) mode) (page 47).

DELETE

| Setting | Description | MODE selector |
|---------|--------------------------------|---------------|
| OK | Deletes the displayed image. | PLAY |
| CANCEL | Cancels deleting of the image. | |

⏪ (RETURN)**

Returns to PLAY (single) mode.

* Displayed only in PLAY (single) mode.

** Displayed only in PLAY (INDEX) mode.

38

► **Various recording**

Setting the image size (IMAGE SIZE)

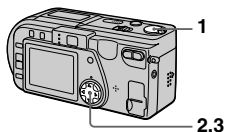

- 1 Set the **MODE** selector to **MOVIE** or **STILL**.
- 2 Select **[FILE]** and then **[IMAGE SIZE]** from the menu.
- 3 Select the desired image size.

Still image sizes

2048×1536, 2048 (3:2)*, 1600×1200, 1280×960, 640×480

* The image is recorded in 3:2 (horizontal : vertical) size to match the printing paper size ratio of 3:2.

Moving image sizes

320 (HQ*), 320×240, 160×112

* High Quality mode

The number of images or the time that you can record on a "Memory Stick" (8 MB):

| Image size | Number of images or time* |
|------------|---------------------------|
| 2048×1536 | Approx. 5 |
| 2048 (3:2) | Approx. 5 |
| 1600×1200 | Approx. 8 |
| 1280×960 | Approx. 12 |
| 640×480 | Approx. 118 |
| 320 (HQ) | Approx. 20 (15**) sec. |
| 320×240 | Approx. 80 (15**) sec. |
| 160×112 | Approx. 320 (60**) sec. |

* When [REC MODE] is set to [NORMAL].

** Numbers in parentheses indicate the maximum recording time during continuous recording.

▼ Various recording

39

Creating Clip Motion Files

Clip Motion is an animation function that plays back still images in succession. Clip Motion images are played back on this camera at approximately 0.5 s intervals. The images are stored in GIF format, which is convenient for creating home pages or attaching images to e-mail.

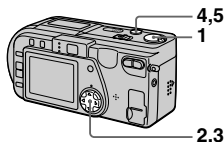

- 1 Set the **MODE** selector to **STILL**.
- 2 Select **[FILE]** and then **[CLIP MOTION]** from the menu.
- 3 Select the desired mode.

160×120 (NORMAL)

Clip Motion of up to 10 frames can be recorded. This is suitable for use on home pages, etc.

80×72 (MOBILE)

Clip Motion of up to 2 frames can be recorded. This is suitable for use with portable data terminals.

CANCEL

This cancels the creation of Clip Motion.

- 4 Record the image for the first frame.

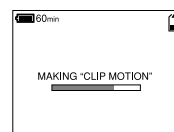

- 5 Record the image for the next frame.

Image recording can be repeated up to the maximum number of recordable frames.

The frame images are automatically recorded on the "Memory Stick" when you select [FINISH] or after recording the maximum number of frames.

To stop Clip Motion creation

Select [RETURN] after step 3. Note that if you record even one frame, you cannot stop Clip Motion creation.

The number of Clip Motion frames that you can record on a "Memory Stick" (8 MB):

| Image size | Number of images |
|------------------|------------------|
| 160×120 (NORMAL) | Approx. 40* |
| 80×72 (MOBILE) | Approx. 800 |

* When recording 10 frames per Clip Motion file

Notes

- Reading and writing data takes more time than normal image recording.
- Due to the limitations of the GIF format, the number of colors for Clip Motion images is reduced to 256 colors or less. Therefore, the picture quality may deteriorate for some images.
- The file size is reduced in MOBILE mode, so the picture quality deteriorates.
- GIF files not created on this camera may not be displayed correctly.

40

Recording still images for e-mail (E-MAIL)

E-MAIL mode records a small-size (320×240) image at the same time as a still image. Small-size images are convenient for e-mail transmission, etc.

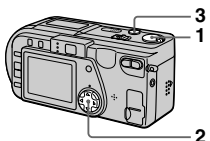

- 1 Set the **MODE** selector to **STILL**.
- 2 Select **[FILE]**, **[REC MODE]**, and then **[E-MAIL]** from the menu.
- 3 Record the image.

The number of images that you can record on a "Memory Stick" (8 MB) in E-MAIL mode:

| Image size | Number of images |
|------------|------------------|
| 2048×1536 | Approx. 4 |
| 2048 (3:2) | Approx. 4 |
| 1600×1200 | Approx. 8 |
| 1280×960 | Approx. 12 |
| 640×480 | Approx. 95 |

To return to normal recording mode

Select [NORMAL] in step 2.

Recording still images with audio files (VOICE)

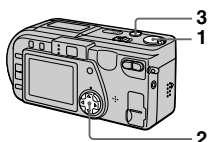

- 1 Set the **MODE** selector to **STILL**.
- 2 Select **[FILE]**, **[REC MODE]**, and then **[VOICE]** from the menu.
- 3 Record the image.

If you press and release the shutter button, sound is recorded for 5 seconds.

If you hold down the shutter button, sound is recorded until you release the shutter button for up to 40 seconds.

The number of images that you can record on a "Memory Stick" (8 MB) in VOICE mode (when recording sound for five seconds):

| Image size | Number of images |
|------------|------------------|
| 2048×1536 | Approx. 4 |
| 2048 (3:2) | Approx. 4 |
| 1600×1200 | Approx. 7 |
| 1280×960 | Approx. 11 |
| 640×480 | Approx. 56 |

To return to normal recording mode

Select [NORMAL] in step 2.

▼ Various recording

41

Recording text documents (TEXT)

Text is recorded in black and white GIF format to provide a clearer image.

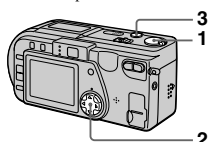

- 1 Set the **MODE** selector to **STILL**.
- 2 Select **[FILE]**, **[REC MODE]**, and then **[TEXT]** from the menu.
- 3 Record the image.

The number of images that you can record on a "Memory Stick" (8 MB) in TEXT mode:

| Image size | Number of images |
|------------|--------------------|
| 2048×1536 | Approx. 15 to 125 |
| 2048 (3:2) | Approx. 17 to 137 |
| 1600×1200 | Approx. 25 to 173 |
| 1280×960 | Approx. 40 to 228 |
| 640×480 | Approx. 160 to 727 |

To return to normal recording mode

Select [NORMAL] in step 2.

Notes

- If the subject is not evenly illuminated, you may be unable to record a clear image.
- Writing and reading data takes more time than in normal recording.

42

Recording still images as uncompressed files (TIFF)

This mode simultaneously records still images in both TIFF format (uncompressed) and JPEG format (compressed).

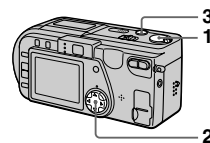

- 1 Set the **MODE** selector to **STILL**.
- 2 Select **[FILE]**, **[REC MODE]**, and then **[TIFF]** from the menu.
- 3 Record the image.

The number of images that you can record on a "Memory Stick" (16 MB) in TIFF mode:

| Image size | Number of images |
|------------|------------------|
| 2048×1536 | Approx. 1 |
| 2048 (3:2) | Approx. 1 |

To return to normal recording mode

Select [NORMAL] in step 2.

Notes

- JPEG images are recorded in the image size selected by the [IMAGE SIZE] menu. TIFF images are recorded in [2048×1536] size other than when [2048 (3:2)] is selected.
- Writing data takes more time than in normal recording.
- The supplied "Memory Stick" (8 MB) does not have sufficient capacity to record uncompressed images.

Recording images in macro

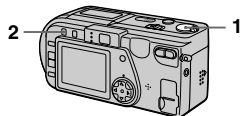

- 1 Set the MODE selector to MOVIE or STILL.
- 2 Press MACRO so that the (auto macro) indicator appears on the LCD screen. You can record a subject as close as about 4 inches (10 cm) from the lens surface with the zoom set all the way to the W side. (About 19 3/4 inches (50 cm) on the T side)

To return to normal recording mode

Press MACRO again so that disappears from the LCD screen.

Notes

- You cannot record images in macro with the following PROGRAM AE modes.
 - Landscape mode
 - Panfocus mode
- You cannot record images in macro when appears on the LCD screen.
- When recording images in macro, use the LCD screen. If you record using the finder, the range visible in the finder may differ from the actual recording range.

Using the PROGRAM AE function

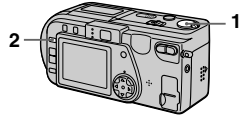

- 1 Set the MODE selector to MOVIE or STILL.
- 2 Press PROGRAM AE repeatedly to select the desired PROGRAM AE mode.

Twilight mode

Suppresses the washed-out color of a bright subject in a dark place so that you can record the subject without losing the dark atmosphere of the surroundings.

Twilight plus mode

Increases the effectiveness of the twilight mode function.

Landscape mode

Focuses only on a distant subject to record landscapes, etc.

Panfocus mode

Changes the focus quickly and simply from a close subject to a distant subject.

▶ Various recording

43

Spot light-metering mode

Select this mode when there is backlight or when there is strong contrast between the subject and the background, etc. Position the point you want to record on the spot light-metering cross hair.

LCD screen

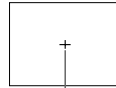

Spot light-metering cross hair

To cancel PROGRAM AE

Press PROGRAM AE repeatedly until the indicator on the LCD screen goes out.

Notes

- You can focus only on distant subjects in Landscape mode.
- In Panfocus mode, the zoom position and focus are fixed.
- When you record in the Twilight plus mode, we recommend that you use a tripod to prevent shaking.
- Set the forced flash when you use the flash in the following modes:
 - Twilight mode
 - Twilight plus mode
 - Landscape mode
- You cannot use the PROGRAM AE function when [REC MODE] is set to [TEXT].
- The noise may increase in twilight plus mode.

Adjusting the exposure (EXPOSURE)

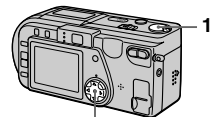

- 1 Set the MODE selector to MOVIE or STILL.
- 2 Select [CAMERA] and then [EXPOSURE] from the menu.
- 3 Select the desired exposure value. Adjust the exposure value while checking the brightness of the background. You can select values ranging from +2.0 EV to -2.0 EV in steps of 1/3 EV.

Note

The exposure may not be adjusted properly when the subject is extremely bright or dark, or when using the flash.

44

Adjusting the white balance (WHITE BALANCE)

Normally the white balance is automatically adjusted.

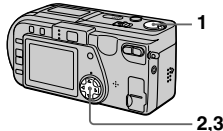

- 1 Set the MODE selector to MOVIE or STILL.
- 2 Select [CAMERA] and then [WHITE BALANCE] from the menu.
- 3 Select the desired white balance setting.

IN DOOR (☀)

- Places where the lighting condition changes quickly
- Under bright lighting such as photography studios
- Under sodium or mercury lamps

OUT DOOR (☀)

Recording a sunrise/sunset, night scene, neon signs, or fireworks

HOLD

Recording a single-colored subject or background

AUTO (No indicator)

Adjusts the white balance automatically

To reactivate auto adjustment

Select [AUTO] in step 3.

Note

Select [AUTO] when recording under fluorescent lighting.

Recording the date and time on the still image (DATE/TIME)

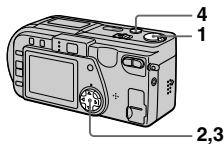

- 1 Set the MODE selector to STILL.
- 2 Select [EFFECT] and then [DATE/TIME] from the menu.
- 3 Select the date and time setting.

DAY&TIME

The date, hour and minutes are imposed onto the image.

DATE

The year, month and day are imposed onto the image.

OFF

The date and time are not imposed onto the image.

- 4 Record the image.

The date and time are not displayed during recording. The date and time are displayed when playing back images.



Notes

- If you select [DATE] in step 3, the date is imposed onto the image in the order selected with "Setting the date and time" (page 12).
- The date and time are not imposed onto Clip Motion images.

▶ Various recording

45

Enjoying picture effects (P.EFFECT)

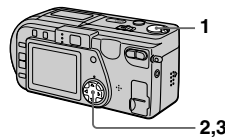

- 1 Set the MODE selector to MOVIE or STILL.
- 2 Select [EFFECT] and then [P.EFFECT] from the menu.
- 3 Select the desired mode.

SOLARIZE

The light contrast is clearer and the picture looks like an illustration.

B&W

The picture is monochrome (black and white).

SEPIA

The picture is colored like an old picture.

NEG.ART

The color and brightness of the picture are reversed.

To cancel picture effect

Select [OFF] in step 3.

46

► **Various playback**

Playing back six images at once (INDEX)

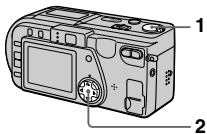

- 1 Set the MODE selector to **PLAY**.
- 2 Select **[INDEX]** on the LCD screen. Six images are displayed at once (index screen). Only the first frame of Clip Motion files is displayed.

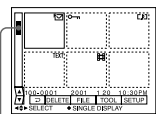

This shows the position of the currently displayed images relative to all the recorded images.

The following marks are displayed on each image according to the image type and settings.

- : Moving image file
- : Voice memo file
- : E-mail file
- : Print mark
- : Protect mark
- TEXT: Text file
- TIFF: TIFF file
- CLIP: Clip Motion file (No mark): Normal recording (no settings)

To display the next (previous) index screen

Select **▲/▼** at the lower left of the LCD screen.

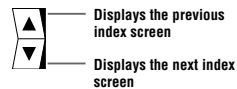

To return to normal playback (single image)

- Select the desired image with the control button.
- Select **[]** (RETURN).

Note

When viewing an image recorded in Clip Motion or TEXT mode on the INDEX screen, the image may appear different from the actual image.

▼ Various playback

Enlarging a part of the still image (Zoom and trimming)

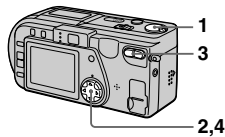

- 1 Set the MODE selector to **PLAY**.
- 2 Display the image to be enlarged.
- 3 Zoom in/out the image with the zoom button. The zoom scaling indicator appears on the LCD screen.
- 4 Press the control button repeatedly to select the desired part of the image.
 - ▲: The image moves downward
 - ▼: The image moves upward
 - ▶: The image moves rightward
 - ◀: The image moves leftward

To return to the normal size

Zoom in with the zoom button until the zoom scaling indicator ($\times 1.1$) disappears from the screen, or simply press **●**.

To record an enlarged image (trimming)

- ① Enlarge the image.
- ② Press the shutter button. The image is recorded at 640x480 size, then the display returns to the image display before enlargement.

Notes

- You cannot trim images recorded in TEXT mode or uncompressed images.
- You cannot zoom or trim Clip Motion images.
- The maximum zoom magnification is 5x the original image, regardless of the image size.
- The picture quality of trimmed images may deteriorate.
- The original picture remains even after trimming.
- The trimmed image is recorded as the newest file.

Rotating a still image (ROTATE)

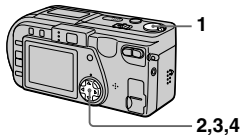

- 1 Set the MODE selector to **PLAY**.
- 2 Display the image to rotate.
- 3 Select **[FILE]** and then **[ROTATE]** from the menu.
- 4 Rotate the image clockwise or counterclockwise, then select **[RETURN]**.

Notes

- You may not be able to rotate images recorded with other equipment.
- Also, when viewing images on a personal computer, the image rotation information may not be reflected depending on the application software.
- You cannot rotate protected or uncompressed images, Clip Motion images or images recorded in TEXT mode.

Playing back the images in order (SLIDE SHOW)

This function is useful for checking the recorded images or for presentations, etc.

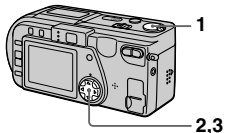

- 1 Set the MODE selector to **PLAY**.
- 2 Select **[FILE]** and then **[SLIDE SHOW]** from the menu. Set the following items.

INTERVAL

1 min (one minute), 30 sec (30 seconds), 10 sec (10 seconds), 5 sec (5 seconds), 3 sec (3 seconds)

REPEAT

ON: Plays back images in a continuous loop until **[RETURN]** is selected.
OFF: After all images have been played back, the slide show ends.

- 3 Select **[START]** with the control button. The slide show begins.

To cancel the slide show
Select **[CANCEL]** in step 2 or 3.

▼ Various playback

To skip to the next/previous image during slide show playback

Select **[▶]/[◀]** at the lower left of the LCD screen. You can skip to the next/previous image by pressing the control buttons **▶/◀** while the menu bar is off.

To pause and restart the slide show

Select **[||]/[▶]** at the bottom left of the screen or press the control button **●** while the menu bar is off to pause and restart the slide show.

Note

The **[INTERVAL]** setting time is approximate, and may vary depending on the played back image size or other factors.

Viewing images on a TV screen

Before connecting your camera, be sure to turn off the TV.

Set the TV/VIDEO switch to "VIDEO."

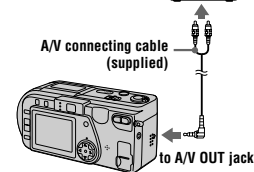

- 1 Connect the A/V connecting cable to the A/V OUT jack of your camera and to the audio/video input jacks of the TV. If your TV has stereo type audio input jacks, connect the audio plug of the A/V connecting cable to the Lch jack.
- 2 Turn on the TV, then start playback on your camera. The playback image appears on the TV screen.

Note

You cannot use a TV that has an antenna (aerial) connector only.

► **Editing**

Preventing accidental erasure (PROTECT)

The  (protect) indicator appears on protected images.

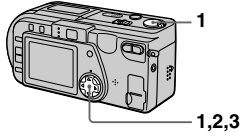

In single mode

- 1 Set the MODE selector to **PLAY**, then display the image to protect.
- 2 Select **[FILE]**, **[PROTECT]**, and then **[ON]** from the menu. The displayed image is protected and  appears.

To release protection

Select **[OFF]** in step 2.

In INDEX mode

- 1 Set the MODE selector to **PLAY**, then display the **INDEX** screen.
- 2 Select **[FILE]**, **[PROTECT]**, and then **[ALL]** or **[SELECT]** from the menu.
- 3 When you select **[ALL]**
Select **[ON]**.
All the images recorded in “Memory Stick” are protected.
When you select [SELECT]
Select all the images to protect with the control button, then select **[ENTER]**.

The selected images are protected.

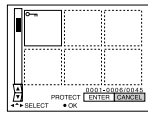

To release protection

If you selected **[ALL]** in step 2, select **[OFF]**. If you selected **[SELECT]** in step 2, select the images to unprotect with the control button, then select **[ENTER]**.

► **Editing**

Changing the recorded still image size (RESIZE)

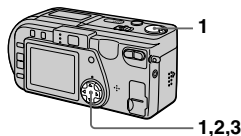

- 1 Set the MODE selector to **PLAY** and display the image to resize.
- 2 Select **[TOOL]** and then **[RESIZE]** from the menu.
- 3 Select the desired image size.
2048x1536, 1600x1200, 1280x960, 640x480
The changed image is recorded, then the display returns to the image display before resizing.

To return to the original size
Select **[CANCEL]** in step 3.

Notes

- You cannot change the size of images recorded in **TEXT** mode, uncompressed images or **Clip Motion** images.
- When you change from a small size to a large size, the picture quality deteriorates.
- The original image is retained even after resizing.
- The resized image is recorded as the newest file.

Copying images (COPY)

You can copy images to another “Memory Stick.”

In single mode

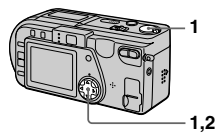

- 1 Set the MODE selector to **PLAY**, then display the image to copy.
- 2 Select **[TOOL]**, **[COPY]**, and then **[OK]** from the menu. “MEMORY STICK ACCESS” appears.
- 3 When “**CHANGE MEMORY STICK**” appears, eject the “Memory Stick.” “**INSERT MEMORY STICK**” appears.
- 4 Insert the “Memory Stick” on which to copy the image. “**RECORDING**” appears. When copying is completed, “**COMPLETE**” appears. To end copying, select **[EXIT]**.

To copy the image to another “Memory Stick”

Select **[CONTINUE]** after step 4 and repeat steps 3 and 4.

► **Editing**

Deleting images (DELETE)

You cannot delete protected files.

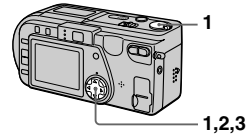

In single mode

- 1 Set the MODE selector to **PLAY**, then display the image to delete.
- 2 Select **[DELETE]** and then **[OK]** from the menu. The image is deleted.

In INDEX mode

- 1 Set the MODE selector to **PLAY**, then display the **INDEX** screen.
- 2 Select **[DELETE]** and then **[ALL]** or **[SELECT]** from the menu.
- 3 When you select **[ALL]**
Select **[ENTER]**.
All unprotected images are deleted.
When you select [SELECT]
Select all the images to delete with the control button, then select **[ENTER]**.

The  (delete) indicator appears on the selected images and these images are deleted.

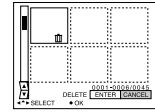

To cancel deleting

Select **[CANCEL]** in step 2 or 3.

Note

If there are files on the “Memory Stick” with names having the same last 4 digits as the file name of the image to be deleted, these files are also deleted at the same time.

In INDEX mode

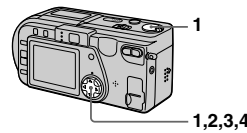

- 1 Set the MODE selector to **PLAY**, then display the **INDEX** screen.
- 2 Select **[TOOL]**, **[COPY]**, and then **[SELECT]** from the menu.
- 3 Select the image to copy. The  (select) indicator appears on the image.
- 4 Select **[ENTER]**. “MEMORY STICK ACCESS” appears.
- 5 When “**CHANGE MEMORY STICK**” is displayed, eject the “Memory Stick.” “**INSERT MEMORY STICK**” appears.
- 6 Insert another “Memory Stick.” “**RECORDING**” appears. When copying is completed, “**COMPLETE**” appears. To end copying, select **[EXIT]**.

To copy the image to another “Memory Stick”

Select **[CONTINUE]** after step 6 and repeat steps 5 and 6.

To cancel copying part-way

Change the MODE selector setting or turn off the power.

Notes

- If you do not select **[EXIT]** after “**COMPLETE**” appears and instead insert a new “Memory Stick,” the same image is copied again.
- You cannot copy uncompressed images.
- You cannot copy images that are bigger than 5 MB at once. If “**NOT ENOUGH MEMORY**” appears or  flashes on the **INDEX** screen, cancel some images to copy and try again.

Selecting still images to print (PRINT MARK)

You can mark a print mark on still images recorded with your camera. This mark is convenient when you have images printed at a shop that conforms with the DPOF (Digital Print Order Format) standard.

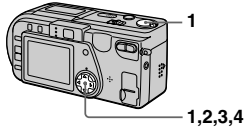

In single mode

- 1 Set the MODE selector to **PLAY** and display the image you want to print.
- 2 Select [FILE], [PRINT MARK], and then [ON] from the menu. The (print) mark is displayed on the image.

To unmark the print mark
Select [OFF] in step 2.

In INDEX mode

- 1 Set the MODE selector to **PLAY**, then display the **INDEX** screen.
- 2 Select [FILE], [PRINT MARK], and then [SELECT] from the menu.
- 3 Select the images to mark with the control button.

- 4 Select [ENTER].
 of the selected images change from green to white.

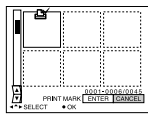

To unmark selected print marks

Select the images to unmark in step 3 with the control button, then select [ENTER].

To unmark all the print marks

Select [FILE], [PRINT MARK], [ALL] and then [OFF] from the menu. of all images are unmarked.

Notes

- You cannot mark moving images, Clip Motion images or images recorded in TEXT mode.
- If you mark an image recorded in TIFF mode with a print mark, only the uncompressed image is printed, and the JPEG image recorded at the same time is not printed.

▶ Editing

55

On battery pack

- Use only the specified charger with the charging function.
- To prevent accident from a short circuit, do not allow metal objects to come into contact with the battery terminals.
- Keep the battery pack away from fire.
- Never expose the battery pack to temperatures above 140°F (60°C), such as in a car parked in the sun or under direct sunlight.
- Keep the battery pack dry.
- Do not expose the battery pack to any mechanical shock.
- Do not disassemble nor modify the battery pack.
- Install the battery pack to the camera securely.
- Charging while some capacity remains does not affect the original battery capacity.

If any problem occurs, unplug your camera and contact your nearest Sony dealer.

On internal rechargeable button battery

This camera has an internal rechargeable button battery for maintaining the date and time and other settings regardless of whether the power is on or off. This rechargeable button battery is constantly charged as long as you are using the camera. However, if you use the camera for only short periods it discharges gradually, and if you do not use the camera at all for about half a year it becomes completely discharged. In this case, be sure to charge this rechargeable button battery before using the camera. However, even if this rechargeable button battery is not charged, you can still use the camera as long as you do not record the date and time.

Charging method

Connect the camera to a wall outlet (mains) with the AC power adaptor, or install a charged battery pack, and leave the camera for 24 hours or more with the POWER switch set to OFF.

On "Memory Sticks"

"Memory Stick" is a new compact, portable and versatile IC recording medium with a data capacity that exceeds a floppy disk. "Memory Stick" is specially designed for exchanging and sharing digital data among "Memory Stick" compatible products. Because it is removable, "Memory Stick" can also be used for external data storage.

There are two types of "Memory Sticks": general "Memory Sticks" and "MagicGate Memory Sticks" that are equipped with the MagicGate® copyright protection technology.

You can use both types of "Memory Stick" with your camera. However, because your camera does not support the MagicGate standards, data recorded with your camera is not subject to MagicGate copyright protection.

* MagicGate is copyright protection technology that uses encryption technology.

Notes

- Do not remove the "Memory Stick" while reading or writing data.
- Data may be damaged if:
 - you remove the "Memory Stick" or turn off your camera while reading or writing data.
 - you use the "Memory Stick" in a location subject to the effects of static electricity or noise.
- Do not attach any other material than the supplied label on the labeling position.
- When you carry or store the "Memory Stick," put it in its supplied case.
- Do not touch the terminals of a "Memory Stick" with your hand or a metal object.
- Do not strike, bend or drop the "Memory Stick."
- Do not disassemble or modify the "Memory Stick."
- Do not allow the "Memory Stick" to get wet.

Additional Information

57

Additional information

Precautions

On cleaning

Cleaning the LCD screen

Wipe the screen surface with a cleaning cloth (not supplied) or a LCD cleaning kit (not supplied) to remove fingerprints, dust, etc.

Cleaning the camera surface

Clean the camera surface with a soft cloth slightly moistened with water, then wipe the surface dry. Do not use any type of solvent such as thinner, alcohol or benzene as this may damage the finish or the casing.

After using your camera at the seashore or other dusty locations

Clean your camera carefully. Otherwise, the salty air may corrode the metal fittings or dust may enter the inside of your camera, causing a malfunction.

Note on operating temperature

Your camera is designed for use between the temperatures of 32°F and 104°F (0°C and 40°C). Recording in extremely cold or hot places that exceed this range is not recommended.

On moisture condensation

If the camera is brought directly from a cold to a warm location, or is placed in a very damp room, moisture may condense inside or outside the camera. Should this occur, the camera will not operate properly.

Moisture condensation occurs easily when:

- The camera is brought from a cold location such as a ski slope into a warmly heated room.
- The camera is taken from an air-conditioned room or car interior to the hot outdoors, etc.

How to prevent moisture condensation

When bringing the camera from a cold place to a warm place, seal the camera in a plastic bag and allow it to adapt to conditions at the new location over a period of time (about an hour).

If moisture condensation occurs

Turn off the camera and wait about an hour for the moisture to evaporate. Note that if you attempt to record with moisture remaining inside the lens, you will be unable to record clear images.

On AC power adaptor

- Unplug the unit from the wall outlet (mains) when you are not using the unit for a long time.
- To disconnect the power cord (mains lead), pull it out by the plug. Never pull the power cord (mains lead) itself.
- Do not operate the unit with a damaged cord or if the unit has been dropped or damaged.
- Do not bend the power cord (mains lead) forcibly, or place a heavy object on it. This will damage the cord and may cause fire or electrical shock.
- Prevent metallic objects from coming into contact with the metal parts of the connecting section. If this happens, a short may occur and the unit may be damaged.
- Always keep metal contacts clean.
- Do not disassemble the unit.
- Do not apply mechanical shock or drop the unit.
- While the unit is in use, particularly during charging, keep it away from AM receivers and video equipment. AM reception and video operation are disturbed.
- The unit becomes warm during use. This is not a malfunction.
- Do not place the unit in locations that are:
 - Extremely hot or cold
 - Dusty or dirty
 - Very humid
 - Vibrating

"Memory Stick", "MagicGate Memory Stick" and are trademarks of Sony Corporation.

"MagicGate" and **MAGICGATE** are trademarks of Sony Corporation.

Using your camera abroad

Power sources

You can use your camera in any country or area with the supplied battery charger within 100 V to 240 V AC, 50/60 Hz. Use a commercially available AC plug adaptor [a], if necessary, depending on the design of the wall outlet (mains) [b].

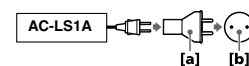

Watching the playback picture on TV

If you want to view the playback picture on a TV, you need a TV having a video input jack and a video connecting cable.

The color system of the TV must be the same as that of your digital still camera. TV color systems differ from country to country. Check the following list:

NTSC system countries

Bahama Islands, Bolivia, Canada, Central America, Chile, Columbia, Ecuador, Jamaica, Japan, Korea, Mexico, Peru, Surinam, Taiwan, the Philippines, the U.S.A., Venezuela, etc.

PAL system countries

Australia, Austria, Belgium, China, Denmark, Finland, Germany, Great Britain, Holland, Hong Kong, Italy, Kuwait, Malaysia, New Zealand, Norway, Portugal, Singapore, Spain, Sweden, Switzerland, Thailand, etc.

PAL-M system country

Brazil

PAL-N system countries

Argentina, Paraguay, Uruguay

SECAM system countries

Bulgaria, Czech Republic, France, Guiana, Hungary, Iran, Iraq, Monaco, Poland, Russia, Slovak Republic, Ukraine, etc.

Troubleshooting

If you experience trouble with your camera, first check the following items. Should your camera still not operate properly after you have made these checks, consult your Sony dealer or local authorized Sony service facility. If code displays (C:□□:□□) appear on the LCD screen, the self-diagnosis display function is working (page 64).

| Symptom | Cause and/or Solution |
|--------------------------------------|--|
| Your camera does not work. | <ul style="list-style-type: none"> You are not using an "InfoLITHIUM" battery pack. → Use an "InfoLITHIUM" battery pack (page 8). The battery level is low (the C indicator appears on the LCD screen). → Charge the battery pack (page 9). The AC power adaptor is not connected securely. → Connect it firmly to the DC IN jack of your camera and a wall outlet (mains) (page 11). The built-in microcomputer is not working properly. → Disconnect and then reconnect all power sources after one minute. Then turn the power on by sliding the POWER switch and check that the camera works properly. |
| Your camera cannot record images. | <ul style="list-style-type: none"> You cannot record images while the flash is charging. The MODE selector is set to PLAY. → Set it to MOVIE or STILL (pages 15, 21). No "Memory Stick" has been inserted into your camera. → Insert a "Memory Stick" (page 14). The write-protect tab on the "Memory Stick" is set to LOCK. → Set it to the recording position. |
| The picture is out of focus. | <ul style="list-style-type: none"> Your camera is not in macro recording mode when you shoot a subject that is about 4 to 19 3/4 inches (10 to 50 cm) away from the lens. → Set the macro recording mode (page 43). Press the zoom button to set to the W side. |
| The resizing function does not work. | <ul style="list-style-type: none"> You cannot resize moving images, text images and Clip Motion images. |
| You cannot display a print mark. | <ul style="list-style-type: none"> You cannot display print marks on moving images, text images and Clip Motion images. |

Additional Information

59

| Symptom | Cause and/or Solution |
|---|---|
| Nothing appears in the display window or the indicators flash during charging. | <ul style="list-style-type: none"> The AC power adaptor is disconnected. → Firmly connect the power cord to the wall outlet (page 11). The battery pack has malfunctioned. → Contact your Sony dealer or local authorized Sony service facility. The battery pack is not installed correctly. → Install the battery pack correctly (page 8). |
| The zoom does not work. | <ul style="list-style-type: none"> PROGRAM AE is set to the Panfocus mode. → Cancel the Panfocus mode (page 43). You cannot use zoom to record moving pictures. |
| Digital zoom does not function. | <ul style="list-style-type: none"> You cannot use digital zoom when recording moving pictures or when the LCD screen is set to OFF. Digital zoom is set to [OFF]. → Set digital zoom to [ON] at the menu. |
| Your camera cannot play back images. | <ul style="list-style-type: none"> The MODE selector is set to STILL or MOVIE. → Set it to PLAY (page 22). |
| The image and sound are interfered by noise when you play back an image on a personal computer. | <ul style="list-style-type: none"> You are playing back the file directly from the "Memory Stick." → Copy the file to the hard disk of the personal computer and then play back the file from the hard disk (page 28). |
| The image cannot be played back on a personal computer. | <ul style="list-style-type: none"> Consult the personal computer or software manufacturer. |
| Your camera cannot delete an image. | <ul style="list-style-type: none"> The image is protected. → Cancel the protection (page 51). |
| The power turns off suddenly. | <ul style="list-style-type: none"> With the MODE selector set to STILL or MOVIE, if you do not operate the camera for about three minutes while the power is on, the camera turns off automatically to prevent wearing down the battery. → Turn on the camera. The battery is discharged. → Replace it with a fully charged battery. (pages 8, 9) |
| The image does not appear on the TV screen. | <ul style="list-style-type: none"> The video output signal setting of your camera is incorrect. → Change the setting (page 38). |

Additional Information

61

| Symptom | Cause and/or Solution |
|--|---|
| The picture is noisy. | <ul style="list-style-type: none"> Your camera is placed near a TV or other equipment that uses strong magnets. → Move your camera away from the TV, etc. |
| The picture is too dark. | <ul style="list-style-type: none"> You are shooting a subject with a light source behind the subject. → Adjust the exposure (page 43). Adjust the brightness of the LCD screen (page 38). |
| The flash does not work. | <ul style="list-style-type: none"> The flash is set to A. → Set the flash to auto (no indicator), P or L (page 20). PROGRAM AE is set to the Twilight, Twilight plus, or Panfocus mode. → Cancel the mode (page 43) or set the flash to L. The MODE selector is set to MOVIE. → Set it to STILL. |
| The date and time are recorded incorrectly. | <ul style="list-style-type: none"> The date and time are not set correctly. → Set the correct date and time (page 12). |
| Vertical streaks appear when you are shooting a very bright subject. | <ul style="list-style-type: none"> The smear phenomenon is happening. → This is not a malfunction. |
| The battery life is short. | <ul style="list-style-type: none"> You are recording/playing back images under extremely cold temperatures. The battery pack is not charged enough. → Charge the battery pack fully. The battery pack is dead. → Replace the battery pack with a new one (page 8). |
| The battery remaining indicator is incorrect. | <ul style="list-style-type: none"> You have used the camera for a long time in an extremely hot or an extremely cold location. The battery pack is dead. → Replace the battery pack with a new one (page 8). The battery pack is discharged. → Install a fully charged battery pack (pages 8, 9). |
| The power goes off although the battery remaining indicator indicates that the battery pack has enough power to operate. | <ul style="list-style-type: none"> Fully charge the battery pack (page 9). |

60

| Symptom | Cause and/or Solution |
|--|--|
| A file error occurs when you play back a file. | <ul style="list-style-type: none"> The image size is larger than 2048x1536. → Reduce the image size on your computer to 2048x1536 or smaller so that it can be played back on this camera. |
| The PROGRAM AE function does not work. | <ul style="list-style-type: none"> The camera is set to text mode. → Cancel text mode (page 42). |
| The LCD screen freezes momentarily. | <ul style="list-style-type: none"> This is a characteristic of the system and is not a malfunction. |
| The picture is monochrome (black and white). | <ul style="list-style-type: none"> The camera is set to TEXT mode. → Cancel TEXT mode (page 42). PEFFECT is set to B&W mode. → Cancel B&W mode (page 46). |
| Your personal computer does not recognize your camera. | <ul style="list-style-type: none"> The camera is turned off. → Turn on the camera. The battery level is low. → Use the AC power adaptor (page 11). The USB cable is not connected firmly. → Disconnect the USB cable, and connect it again firmly. Make sure that "PC MODE" is displayed on the LCD screen (page 26). The USB connectors on your personal computer are connected to other equipment besides the keyboard, the mouse, and your camera. → Disconnect the USB cables except for the ones connected to the keyboard, the mouse, and your camera. |
| The lens does not retract even when the power is turned off. | <ul style="list-style-type: none"> The battery is discharged. → Replace it with a fully charged battery or use the AC power adaptor. |

62

Warning and notice messages

Various messages appear on the LCD screen. Check the corresponding descriptions in the following list.

| Message | Meaning |
|--------------------------------|--|
| NO MEMORY STICK | No "Memory Stick" has been inserted. |
| SYSTEM ERROR | Turn the power off and on again. |
| MEMORY STICK ERROR | The inserted "Memory Stick" cannot be used with your camera, or the "Memory Stick" is damaged or not inserted correctly. |
| FORMAT ERROR | Failed to format the "Memory Stick." |
| MEMORY STICK LOCKED | The write-protect tab on the "Memory Stick" is set to the LOCK position. |
| NO MEMORY SPACE | The capacity of the "Memory Stick" is full, and you cannot record or copy images. |
| NO FILE | No image has been recorded on the "Memory Stick." |
| FILE ERROR | An error occurred while playing back the image. |
| FILE PROTECT | The image is protected against erasure. |
| for "InfoLITHIUM" battery only | The battery is not the "InfoLITHIUM" type. |
| NOT ENOUGH MEMORY | The images you want to copy are too big to copy with your camera. |
| COPY ERROR | Copying was not performed correctly, or the "Memory Stick" was removed during copying. |
| DIRECTORY ERROR | A directory with the same name already exists. |
| IMAGE SIZE OVER | You are playing back an image of a size that cannot be played back with your camera. |
| INVALID OPERATION | You are playing back a file that was created on equipment other than your camera. |
| | The battery level is low or zero. |
| | The image is protected. |

Additional information

63

Display window indicators

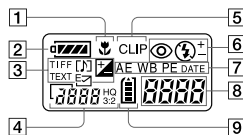

- 1 Macro indicator
- 2 Battery remaining indicator
- 3 Recording mode/EV level indicator
- 4 Image size indicator
- 5 Clip Motion indicator
- 6 Flash mode/flash level indicator
- 7 PROGRAM AE indicator
White balance indicator
Picture effect indicator
Date/time indicator
- 8 Battery usable time indicator (displayed only during charging)
Number of recorded images
Error display
Err: Some kind of misoperation has occurred. Check the self-diagnosis display on the LCD screen (page 64) and take the appropriate corrective action.
LENS: A problem has occurred with lens drive. Turn the camera on and off several times, and if the problem persists, contact your Sony dealer or authorized Sony service facility.
- 9 "Memory Stick" remaining indicator

66

Self-diagnosis display

Your camera has a self-diagnosis display. This function displays the camera condition on the LCD screen with a combination of a letter and four digits of numbers. If this occurs, check the following code chart. The code informs you of the camera's current condition. The last two digits (indicated by □□) will differ depending on the state of the camera.

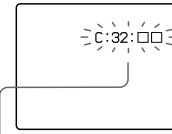

Self-diagnosis display

- C:□□:□□
You can reverse the camera malfunction yourself.
- E:□□:□□
Contact your Sony dealer or local authorized Sony service facility.

| First three digits | Cause and/or Corrective Action |
|--------------------|---|
| C:32:□□ | <ul style="list-style-type: none"> • There is trouble with your camera's hardware or zooming function. → Turn the power off and on again. |
| C:13:□□ | <ul style="list-style-type: none"> • An unformatted "Memory Stick" is inserted. → Format the "Memory Stick" (page 35). • The inserted "Memory Stick" cannot be used with your camera, or is damaged. → Insert a new "Memory Stick" (page 14). |
| E:61:□□ E:91:□□ | <ul style="list-style-type: none"> • A camera malfunction that you cannot reverse has occurred. → Contact your Sony dealer or local authorized Sony service facility and inform them of the 5-digit service code. (example: E:61:10) |

If you are unable to solve the problem even after trying the corrective actions a few times, contact your Sony dealer or local authorized Sony service facility.

When a self-diagnosis display appears

The error display appears on the display window (page 66).

64

LCD screen indicators

The indicators during recording

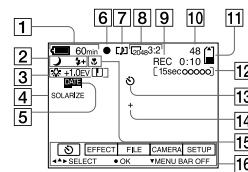

- 1 Battery remaining indicator
- 2 PROGRAM AE/flash level/flash mode indicator
- 3 White balance/EV level/sharpness indicator
- 4 Picture effect indicator
- 5 Date/time indicator
- 6 AE lock indicator/Focus lock indicator
- 7 Recording mode/Clip Motion indicator
- 8 Image size indicator
- 9 Self-diagnosis function/recording time indicator
- 10 Number of recorded images
- 11 Remaining memory capacity indicator
- 12 Moving image/VOICE recording time indicator
- 13 Self-timer indicator
- 14 Spot light-metering indicator
- 15 Macro mode indicator
- 16 Menu bar and guide menu
They appear by pressing ▲ on the control button and disappear by pressing ▼ of it.

Additional information

67

When playing back still images

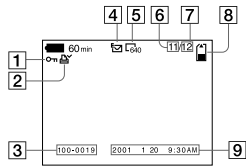

- | | |
|--|--|
| 1 Protect indicator | 6 Image number |
| 2 Print mark indicator | 7 Number of stored images in "Memory Stick" |
| 3 File name | 8 Remaining memory capacity indicator |
| 4 Recording mode/Clip Motion indicator | 9 Recording date of the playback image/menu bar and guide menu |
| 5 Image size indicator | |

When playing back moving images

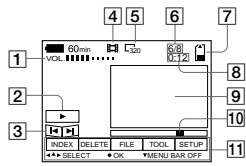

- | | |
|--|--|
| 1 VOL. (Volume) indicator | 6 Image number/number of stored images in "Memory Stick" |
| 2 Playback/pause buttons ▶: during pause II: during playback | 7 Remaining memory capacity indicator |
| 3 Fast-forward/rewind buttons | 8 Counter |
| 4 Recording mode indicator | 9 Playback image |
| 5 Image size indicator | 10 Play bar |
| | 11 Menu bar and guide menu |

SECTION 2 DISASSEMBLY

• This set can be disassembled in the order shown below.

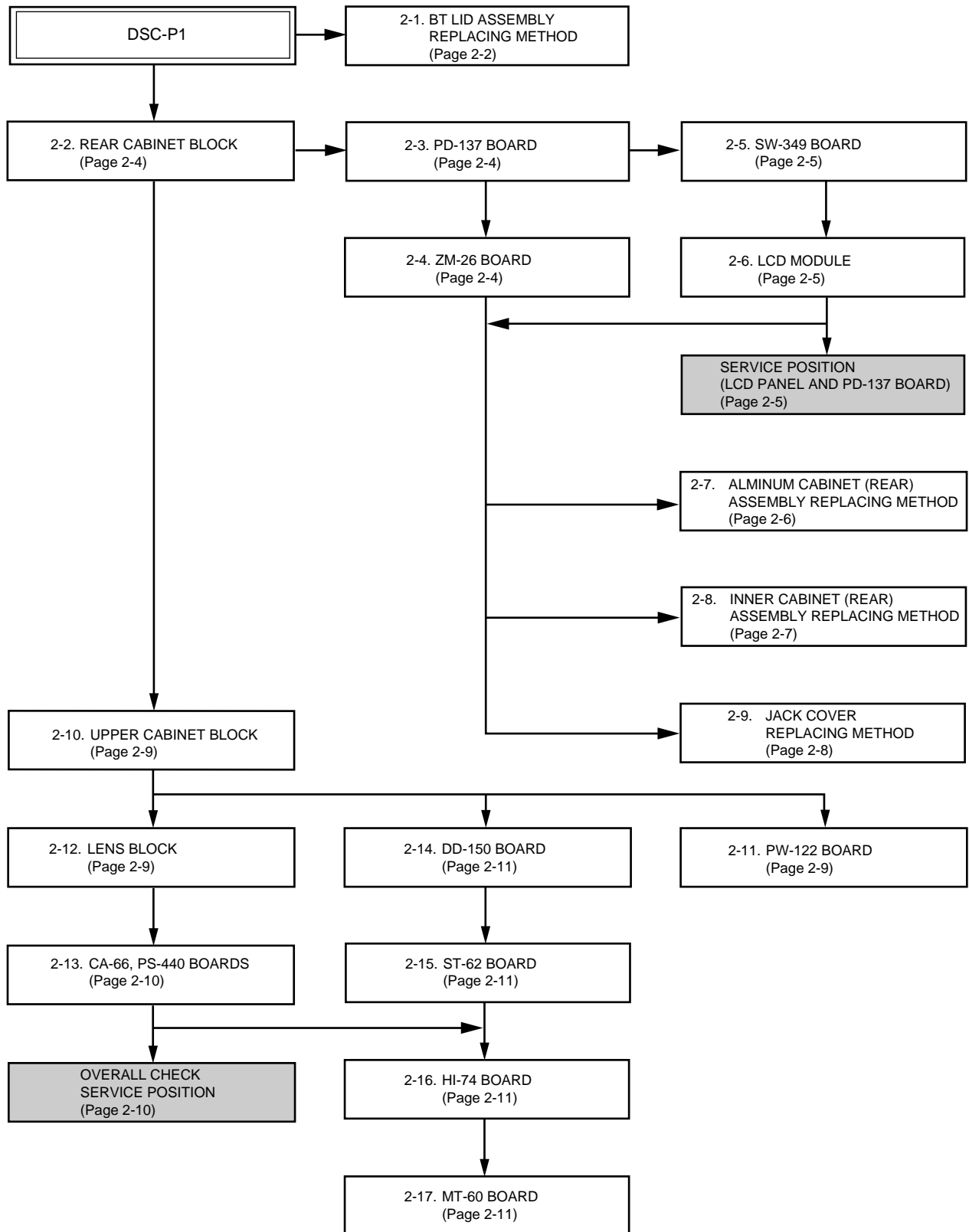

• ATTACHMENT OF CPC-9 JIG

Note 1: Don't use the 12 pin flexible board of CPC-9 jig.
It causes damage to the unit.

Note 2: The old CPC-9 jig (Parts code: J-6082-393-B)
cannot be used, because it cannot operate
the adjustment remote commander.

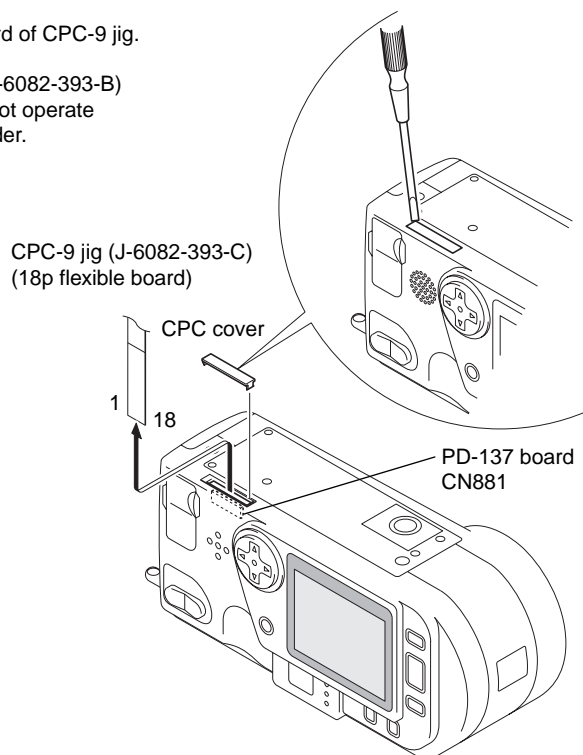

Note: Follow the disassembly procedure in the numerical order given.

2-1. BT LID ASSEMBLY REPLACING METHOD

[Note]

The shape of BT plate varies depending on the last code of BT holder assembly, as shown below. The BT lid assembly for service parts (X-3951-282-1) can be used only for the last code-3 of the BT holder assembly. For the last code-1 and -2 of the BT holder assembly, replace the BT holder assembly.

This portions are different.

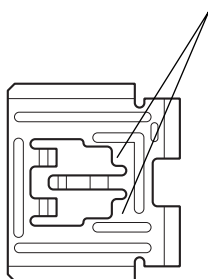

BT plate of BT holder assembly
having last code-1 and -2

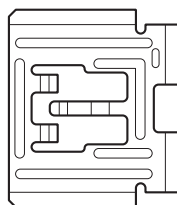

BT plate of BT holder assembly
having last code-3

BT lid assembly

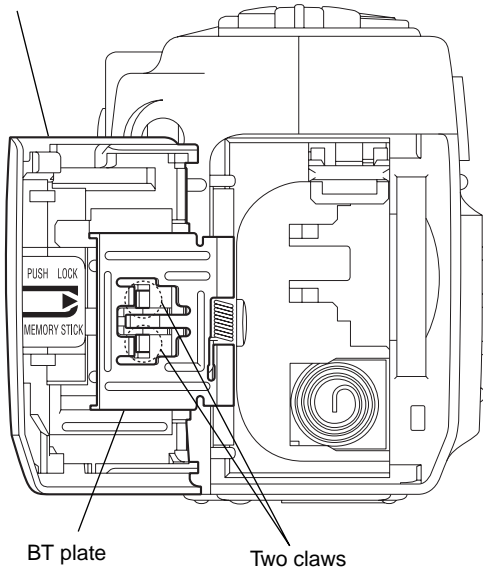

- ① Cut off the two claws of the BT inner lid, and pull off the BT lid assembly in the direction of arrow (A).

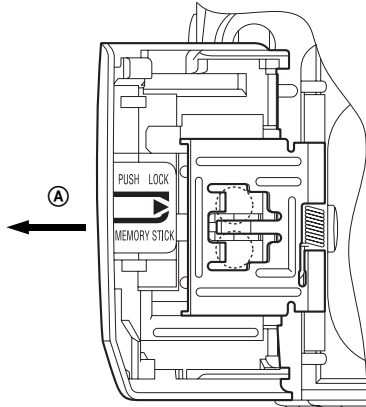

Note: After pulling off the BT lid assembly, take care not to damage the aluminum cabinet by the BT plate which will open by means of a spring force.

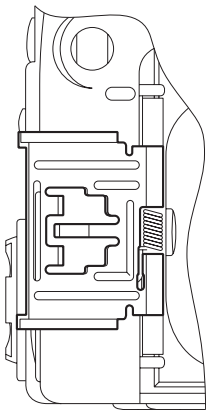

- ② Aligning with the rails of BT plate, slide new BT lid assembly in the direction of arrow (B). In such a case, slide until a click is heard, avoiding a damage of two claws by the end face of BT plate.

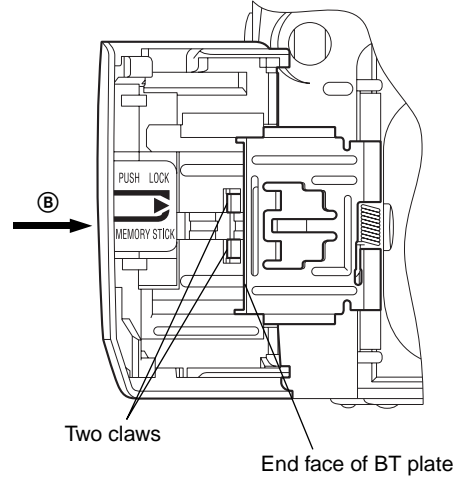

Note: As tricks, slide the BT lid assembly obliquely by the amount of a play to the BT plate as shown in the figure, taking care not to damage the two claws.

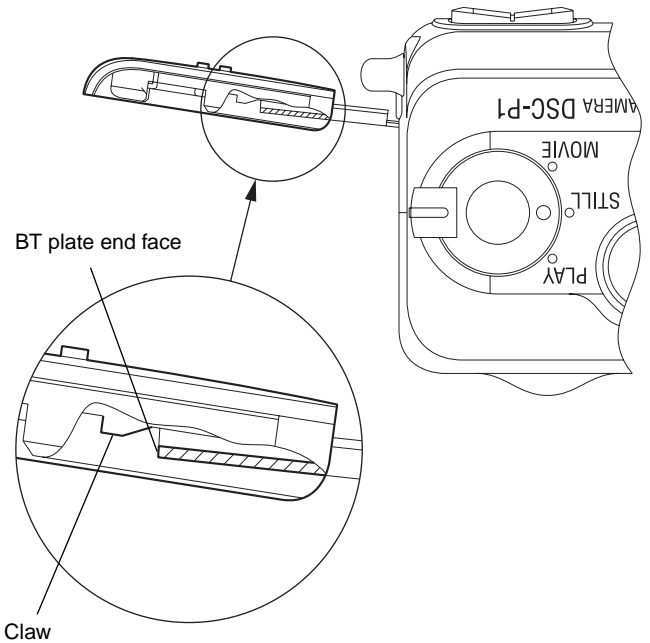

2-2. REAR CABINET BLOCK

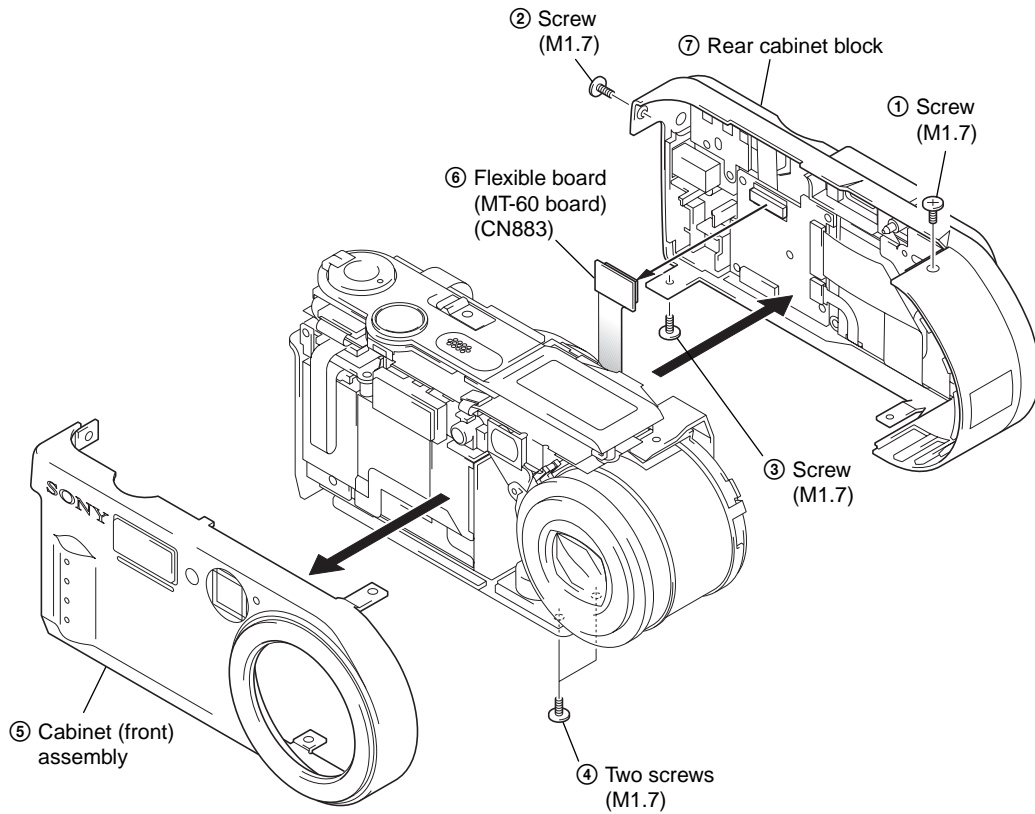

2-3. PD-137 BOARD

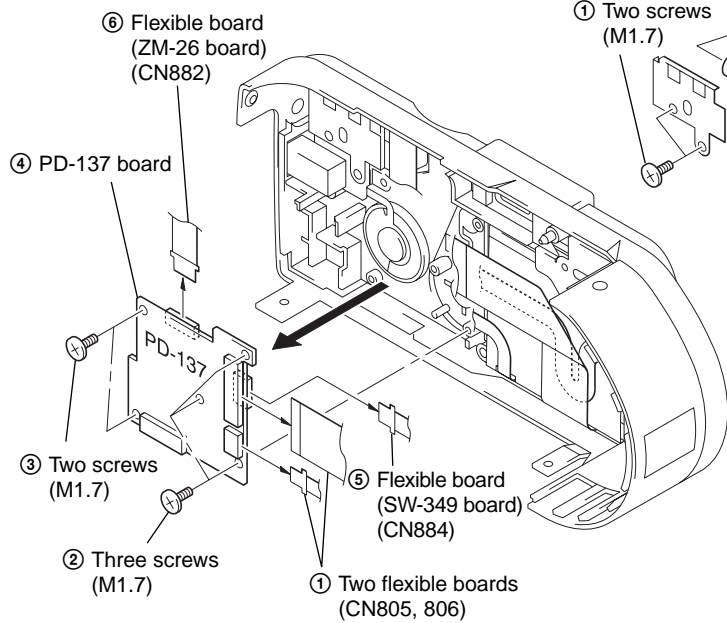

2-4. ZM-26 BOARD

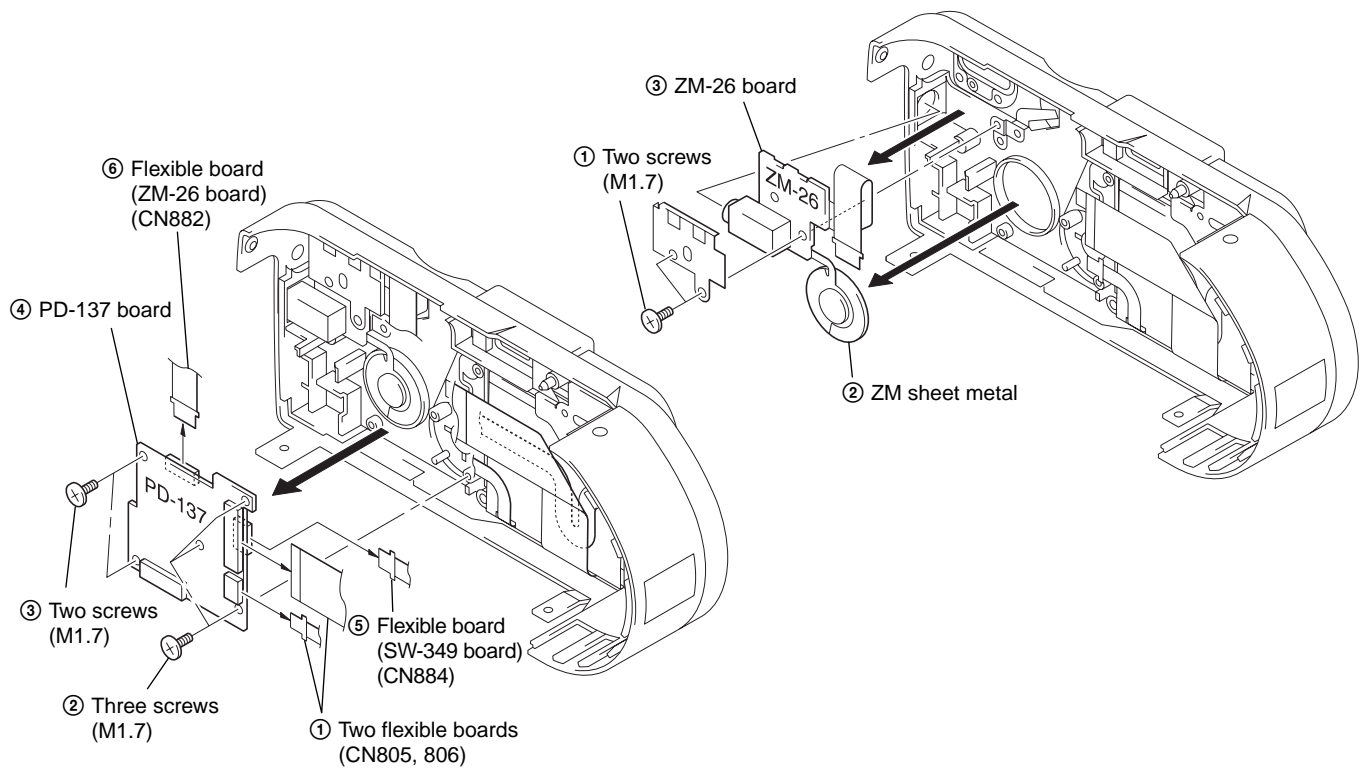

2-5. SW-349 BOARD

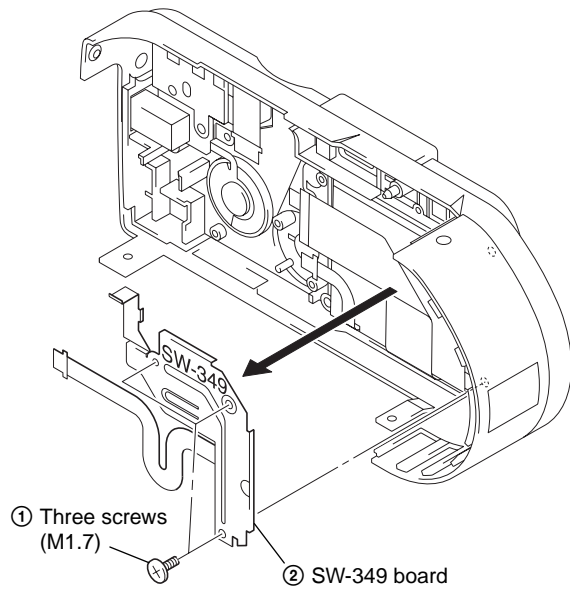

2-6. LCD MODULE

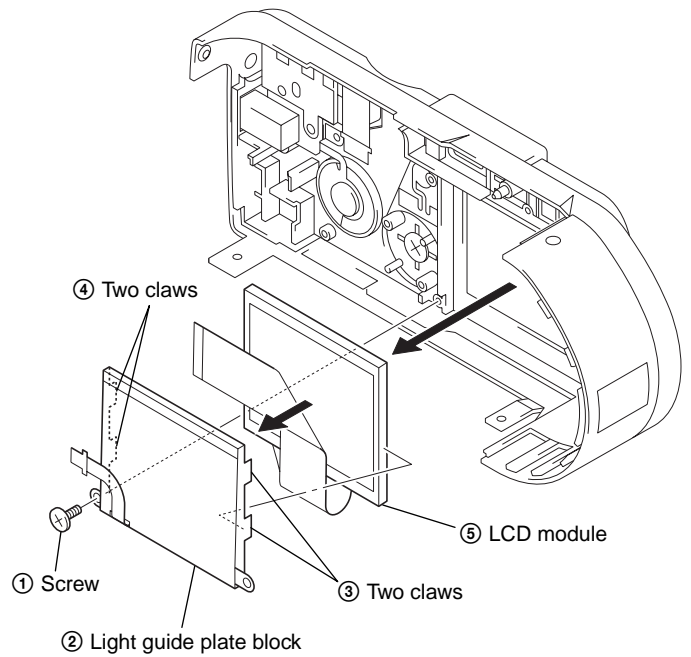

[SERVICE POSITION (LCD PANEL AND PD-137 BOARD)]

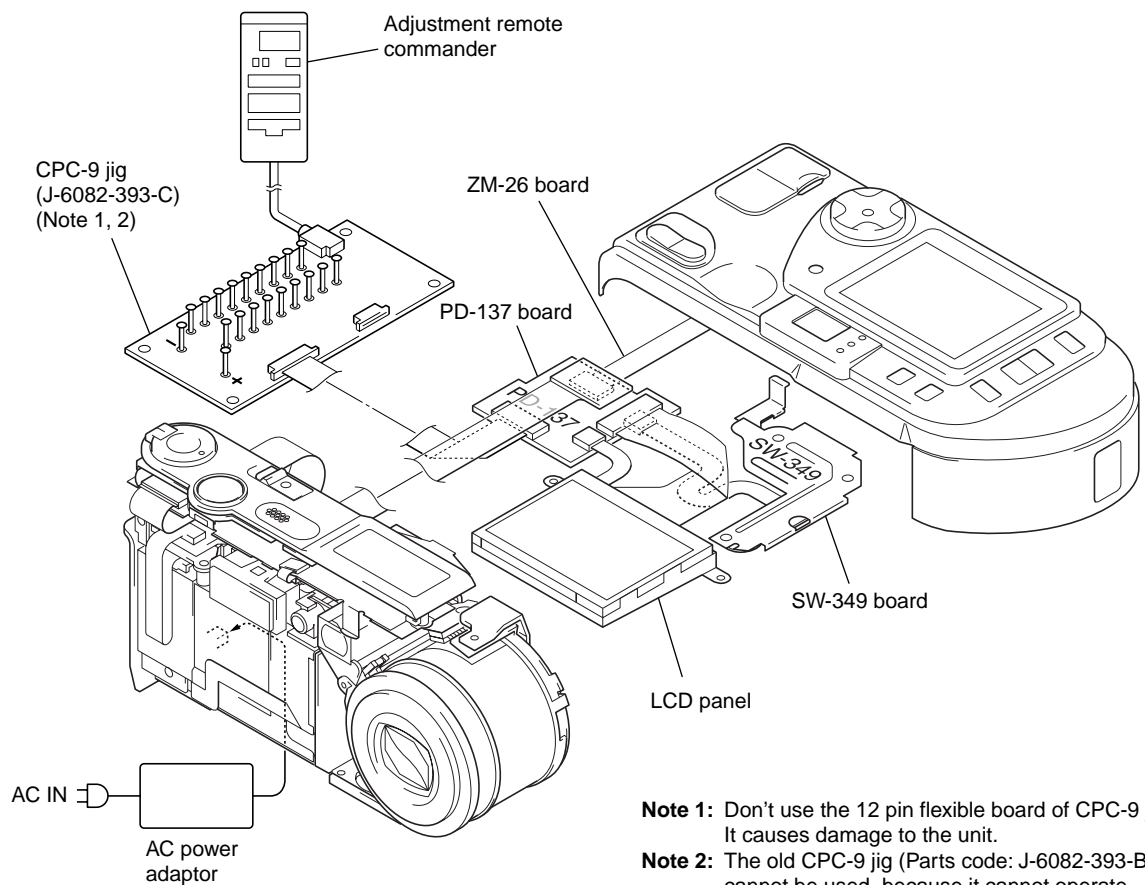

Note 1: Don't use the 12 pin flexible board of CPC-9 jig. It causes damage to the unit.

Note 2: The old CPC-9 jig (Parts code: J-6082-393-B) cannot be used, because it cannot operate the adjustment remote commander.

2-7. ALUMINUM CABINET (REAR) ASSEMBLY REPLACING METHOD

- ① Peel off the light interception sheet (F).

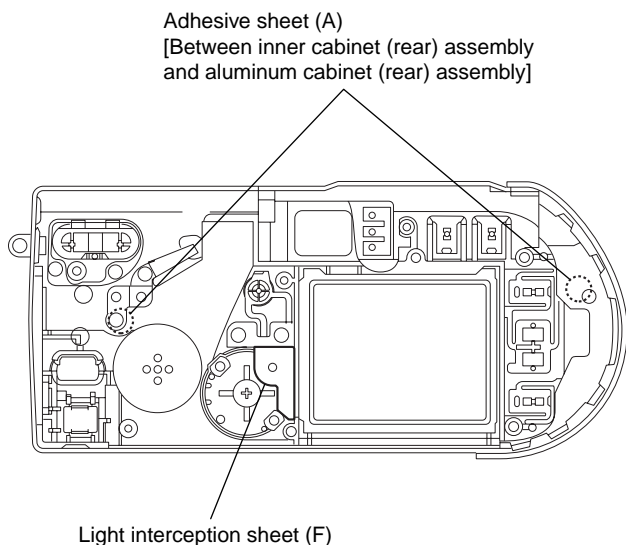

- ④ Affix adhesive sheet (P), aligning with the frame of aluminum cabinet.

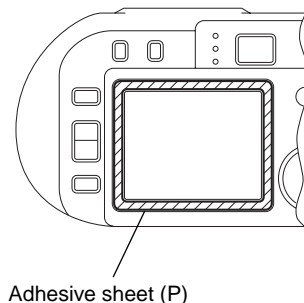

- ⑤ Affix the LCD cover, aligning with the frame of aluminum cabinet.

Note: At this time, do not touch the back of LCD cover. The back surface with a special treatment is easily affected with the pollution.

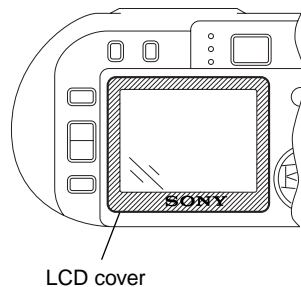

- ② From the inner cabinet (rear) assembly, remove the aluminum cabinet (rear) assembly stuck with adhesive sheet (A) at two places.

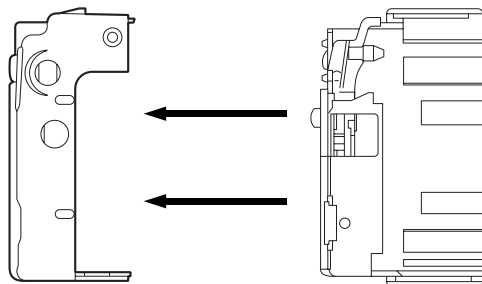

- ③ Insert new aluminum cabinet (rear) assembly, aligning with the inner cabinet. In such a case, make sure that the adhesive sheet (A) is affixed on the inner cabinet side. If adhesive sheet (A) is not present or adhesive force is reduced, affix adhesive sheet (A) (3-064-219-01) to the places shown below before insertion.

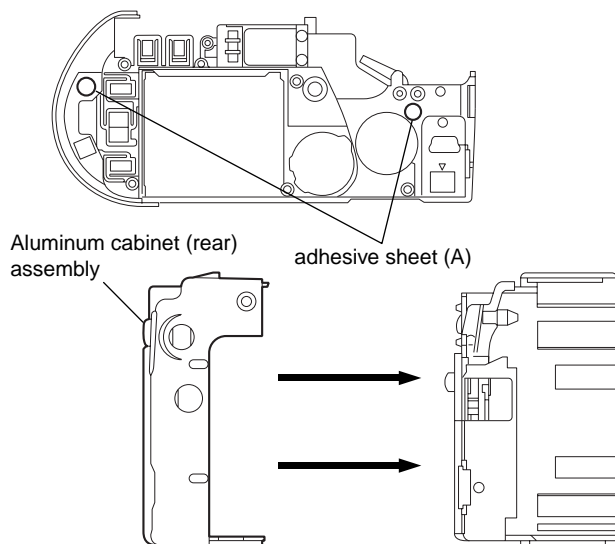

- ⑥ As shown below, affix the light interception sheet (F), aligning with the positioning boss.

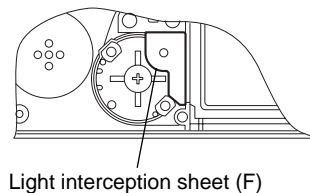

2-8. INNER CABINET (REAR) ASSEMBLY REPLACING METHOD

- ① Peel off the light interception sheet (F).

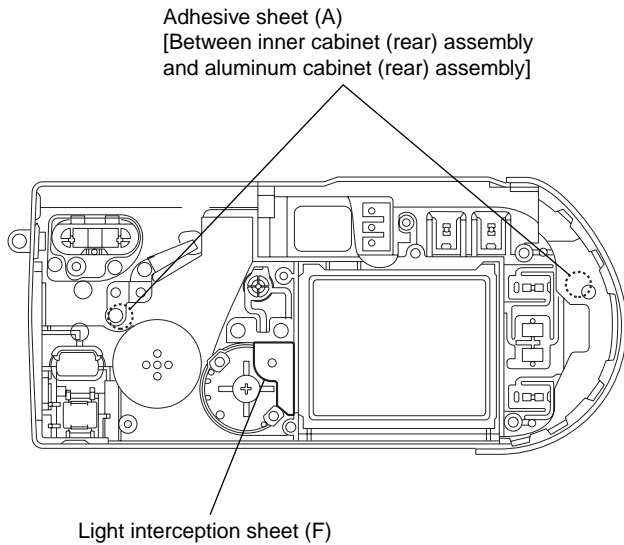

- ② From the aluminum cabinet (rear) assembly, remove the inner cabinet (rear) assembly stuck with adhesive sheet (A) at two places.

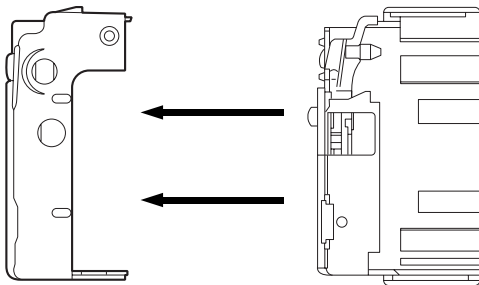

- ③ Pull off the forcibly fitted parallel pin (dia. 1.6 × 5) in the direction of arrow (A).

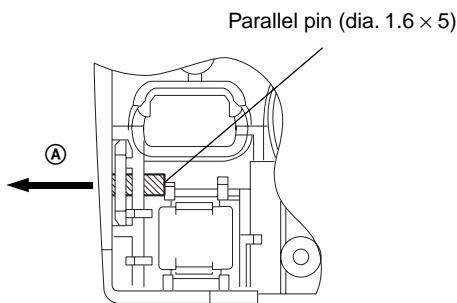

- ④ Pull the jack cover off the inner cabinet (rear).

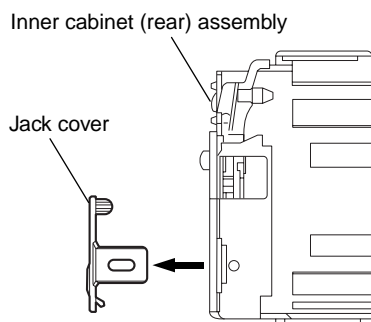

- ⑤ Insert the jack cover into new inner cabinet (rear) assembly.

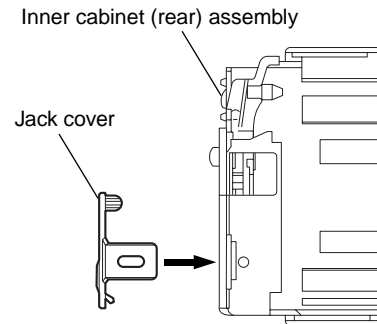

- ⑥ Forcibly fit the Parallel pin (dia. 1.6 × 5).

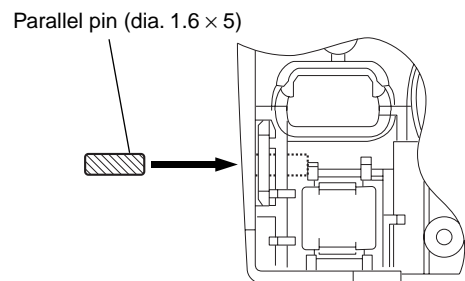

- ⑦ Check if adhesive sheet (A) remains on the aluminum cabinet side, and if so, remove it. Peel stripping sheet off the adhesive sheet (A) at two places in the inner cabinet (rear) assembly. Insert the inner cabinet (rear) assembly, aligning with the aluminum cabinet.

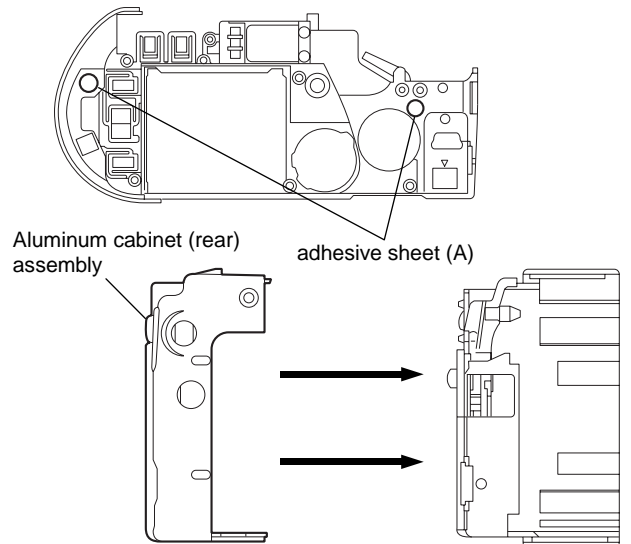

- ⑧ As shown below, affix the light interception sheet (F), aligning with the positioning boss.

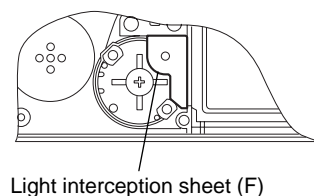

2-9. JACK COVER REPLACING METHOD

- ① Peel off the light interception sheet (F).

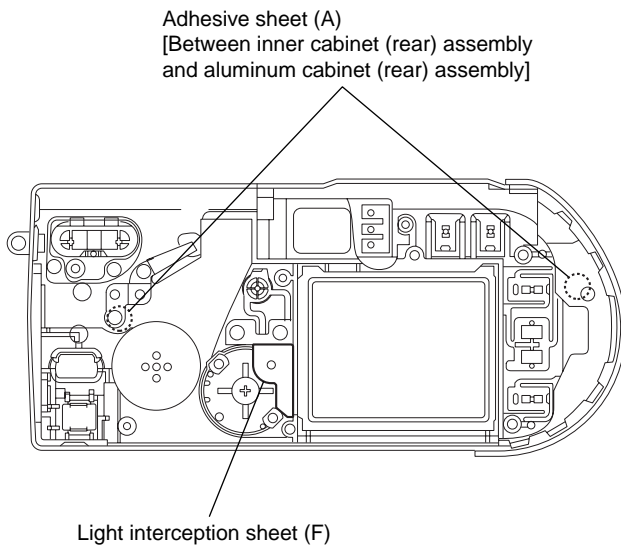

- ② From the aluminum cabinet (rear) assembly, remove the inner cabinet (rear) assembly stuck with adhesive sheet (A) at two places.

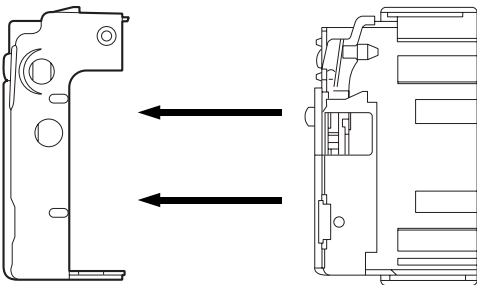

- ⑤ Insert new jack cover into the inner cabinet (rear) assembly.

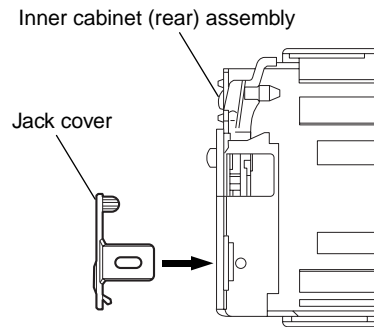

- ⑥ Forcibly fit the Parallel pin (dia. 1.6 × 5).

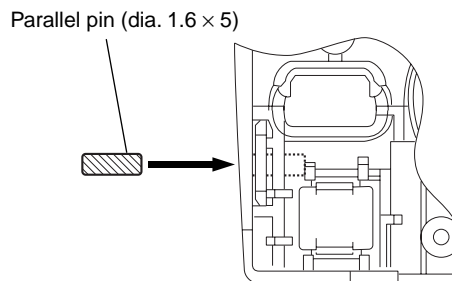

- ⑦ Insert the inner cabinet, aligning with the aluminum cabinet. In such a case, if adhesive sheet (A) is not present or an adhesive force is reduced, affix adhesive sheet (A) (3-064-219-01) before insertion.

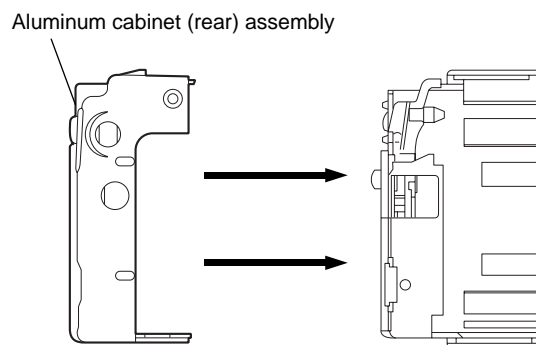

- ③ Pull off the forcibly fitted parallel pin (dia. 1.6 × 5) in the direction of arrow (A).

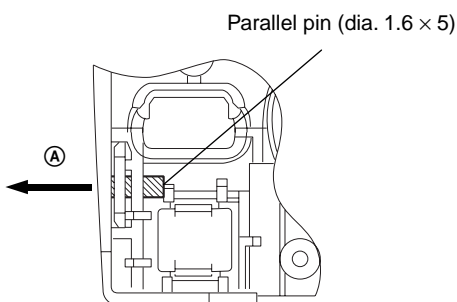

- ④ Pull the jack cover off the inner cabinet (rear).

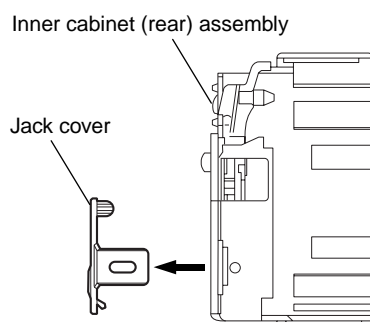

- ⑧ As shown below, affix the light interception sheet (F), aligning with the positioning boss.

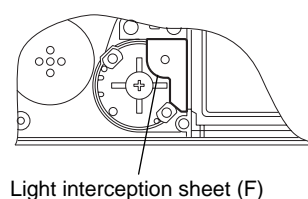

2-10. UPPER CABINET BLOCK

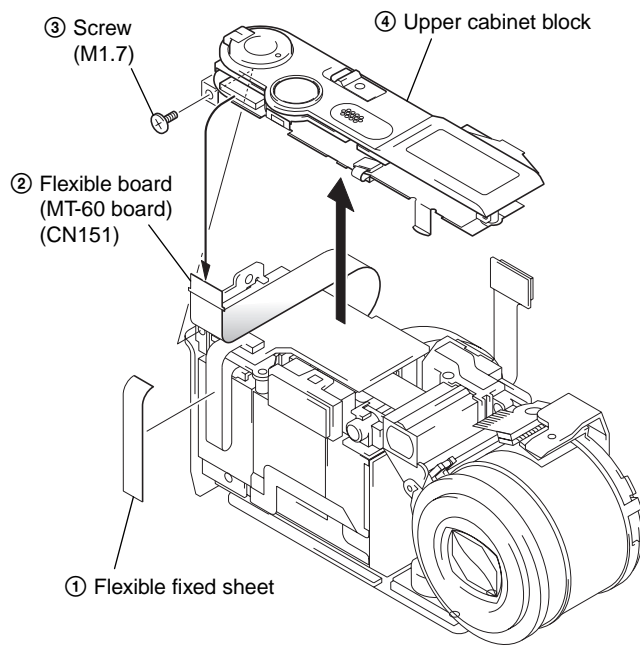

2-11. PW-122 BOARD

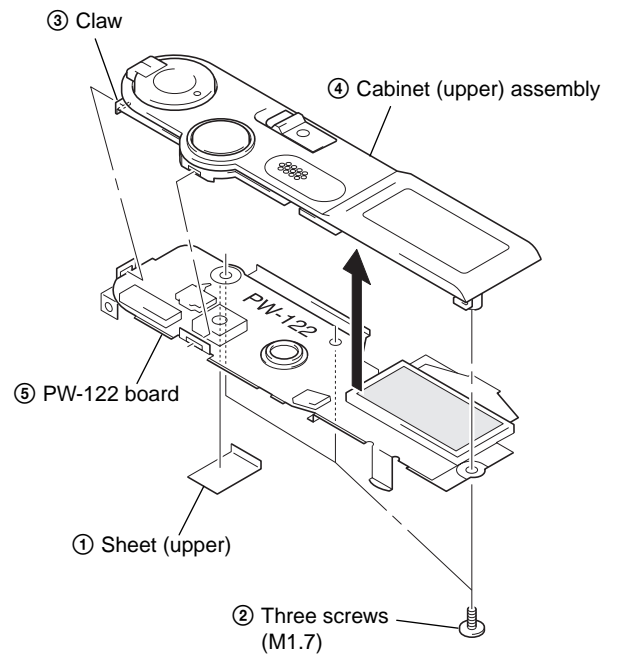

2-12. LENS BLOCK

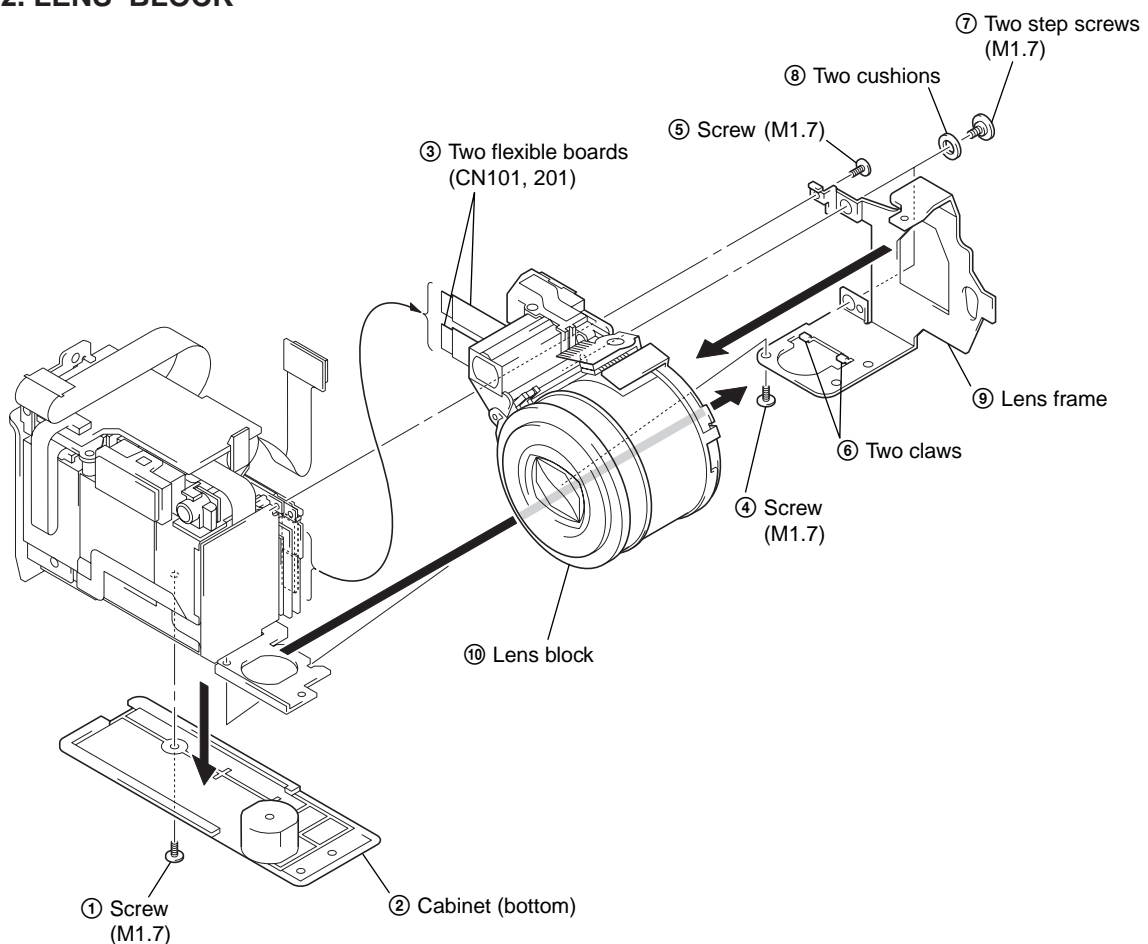

2-13. CA-66, PS-440 BOARDS

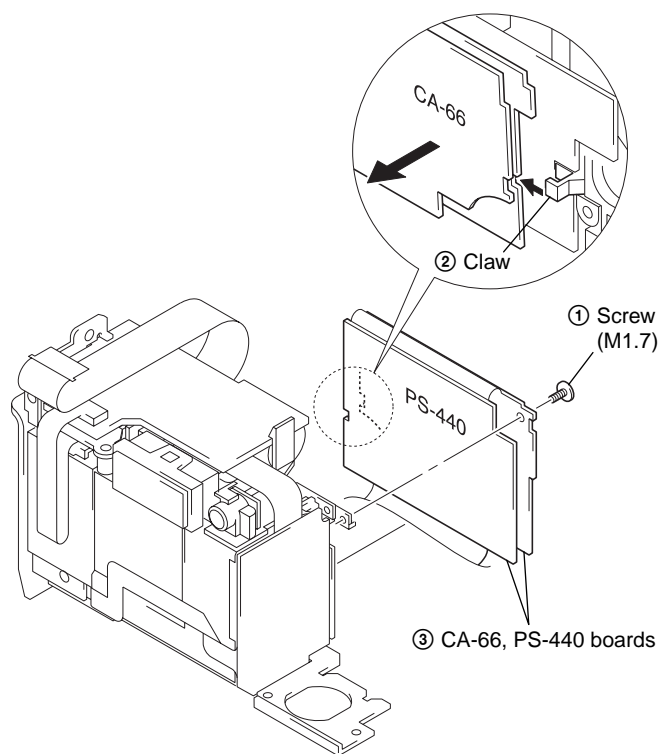

[OVERALL CHECK SERVICE POSITION]

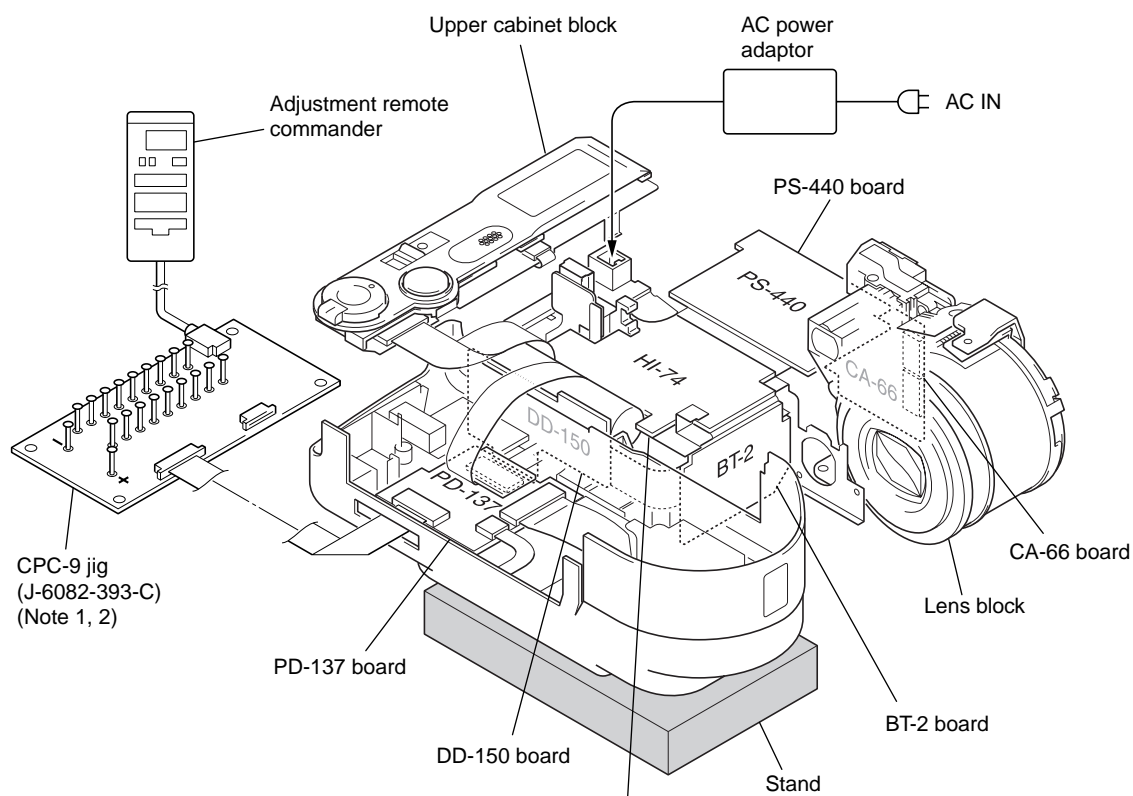

Note 1: Don't use the 12 pin flexible board of CPC-9 jig. It causes damage to the unit.

Note 2: The old CPC-9 jig (Parts code: J-6082-393-B) cannot be used, because it cannot operate the adjustment remote commander.

2-14. DD-150 BOARD

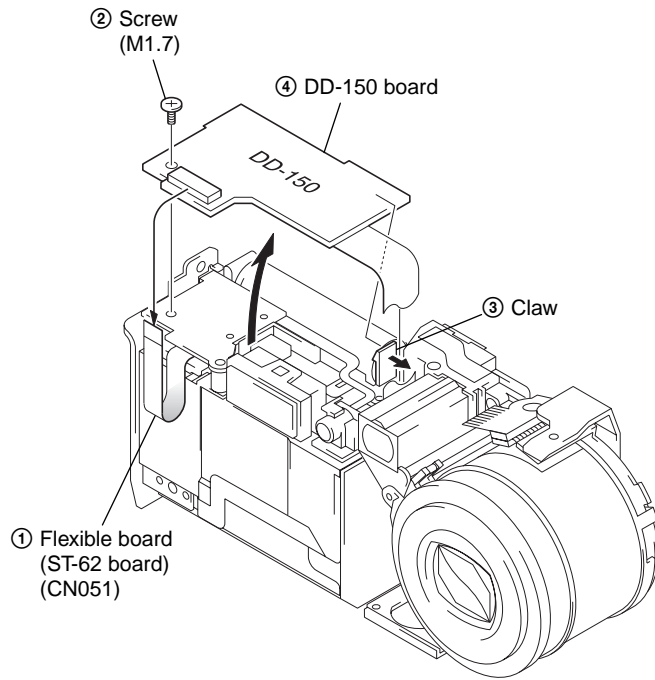

2-16. HI-74 BOARD

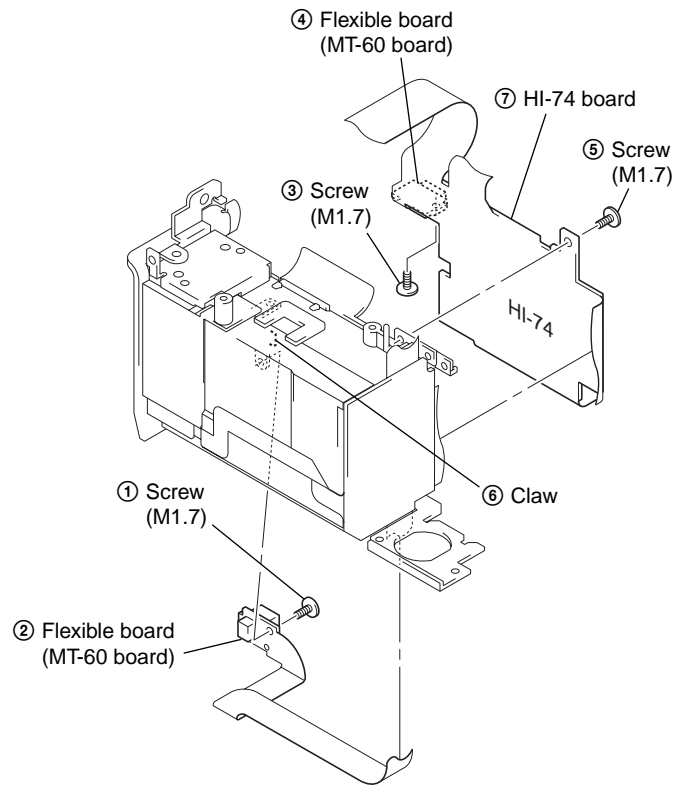

2-15. ST-62 BOARD

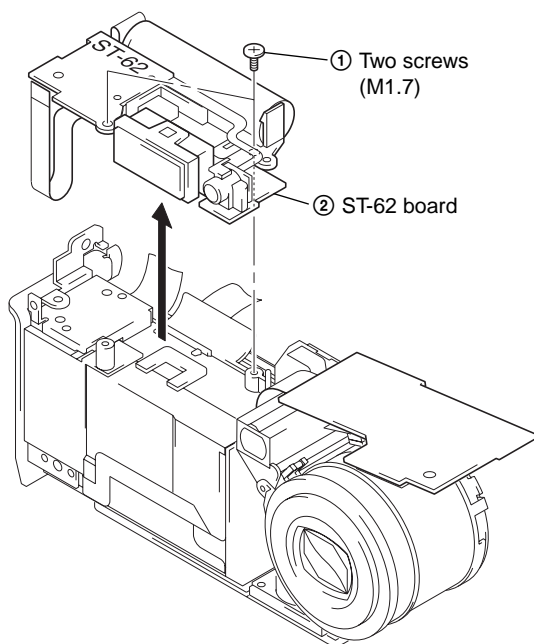

2-17. MT-60 BOARD

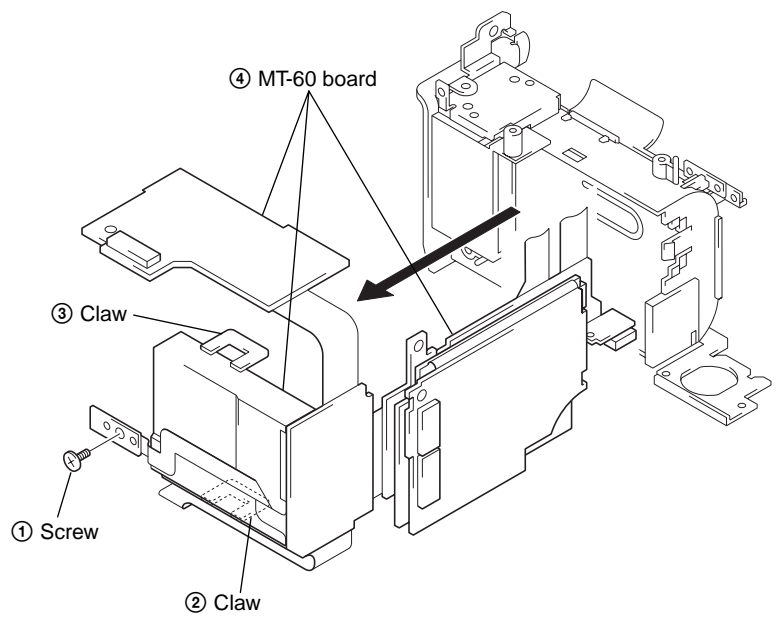

2-18. CIRCUIT BOARDS LOCATION

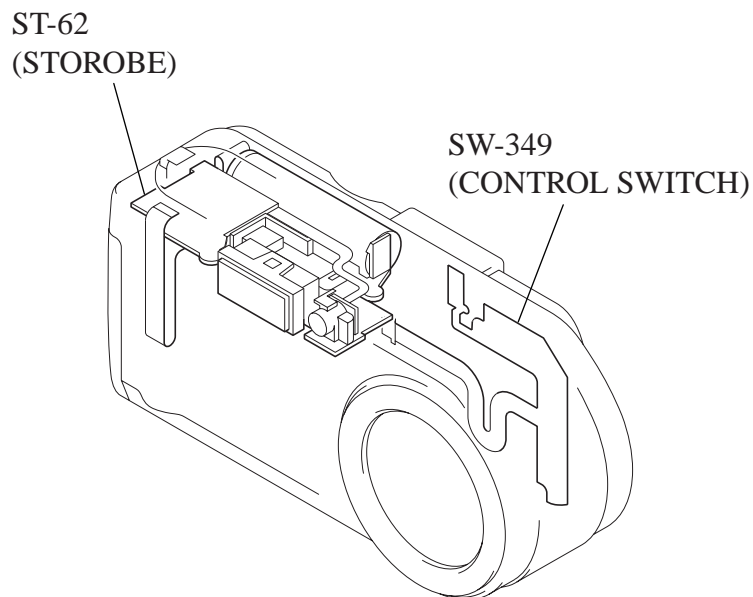
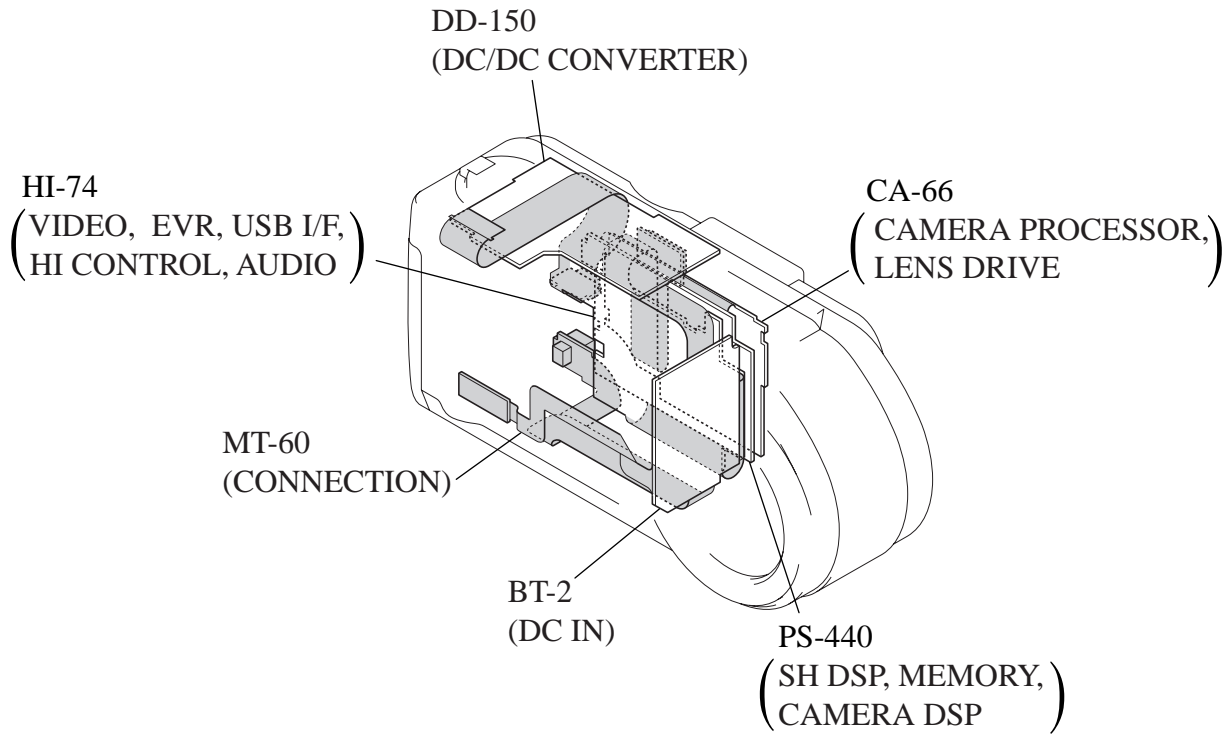

ZM-26
(ZOOM SWITCH)

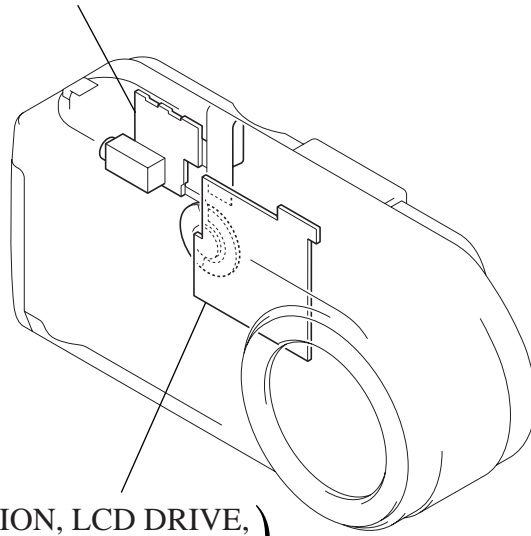

PD-137
(CONNECTION, LCD DRIVE,
TIMING GENERATOR)

PW-122
(LCD DRIVER)

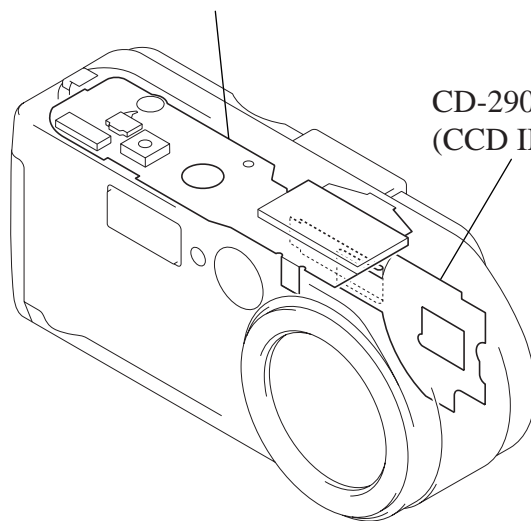

CD-290
(CCD IMAGER)

SECTION 3 BLOCK DIAGRAMS

3-1. OVERALL BLOCK DIAGRAM

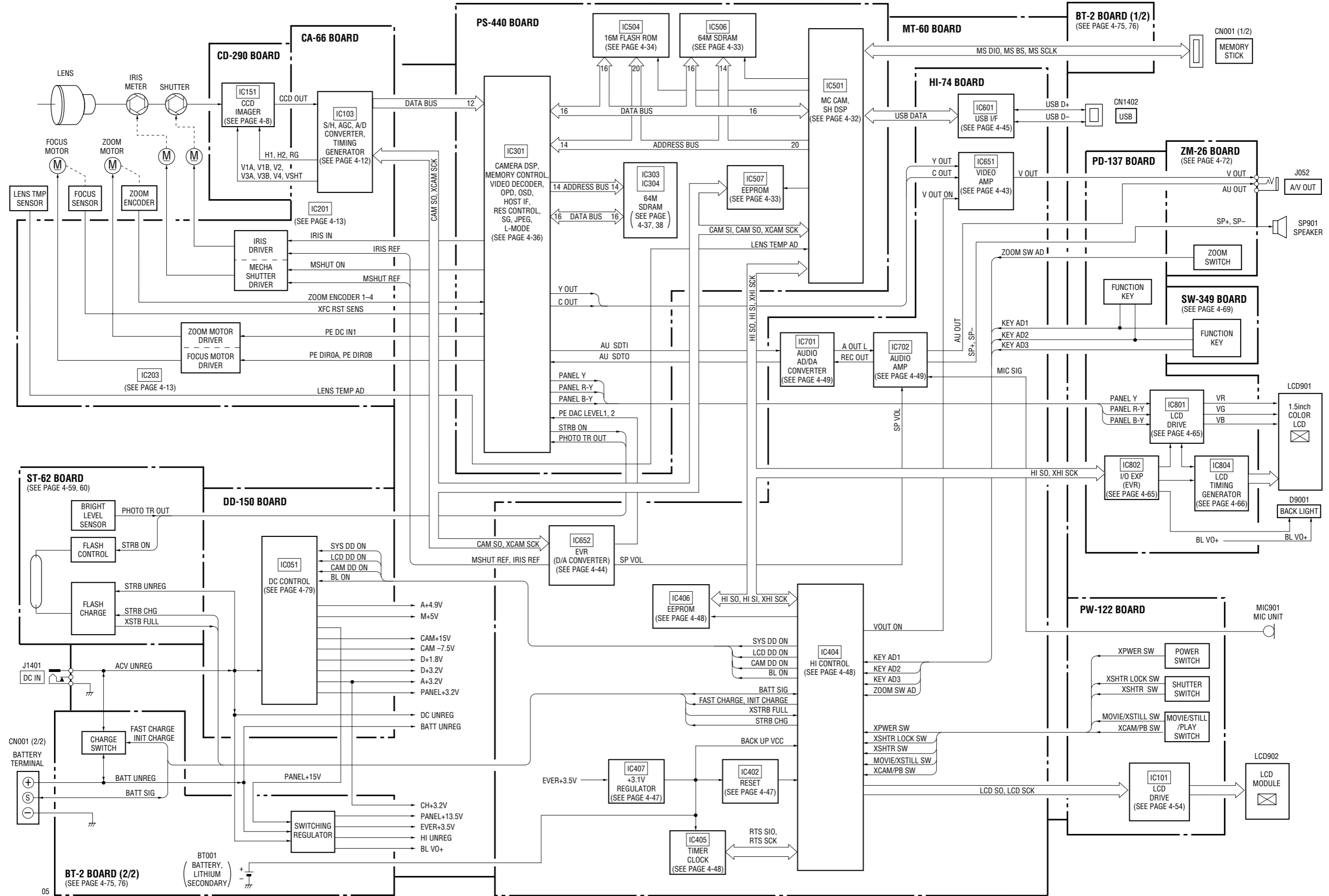

3-8. POWER BLOCK DIAGRAM 1

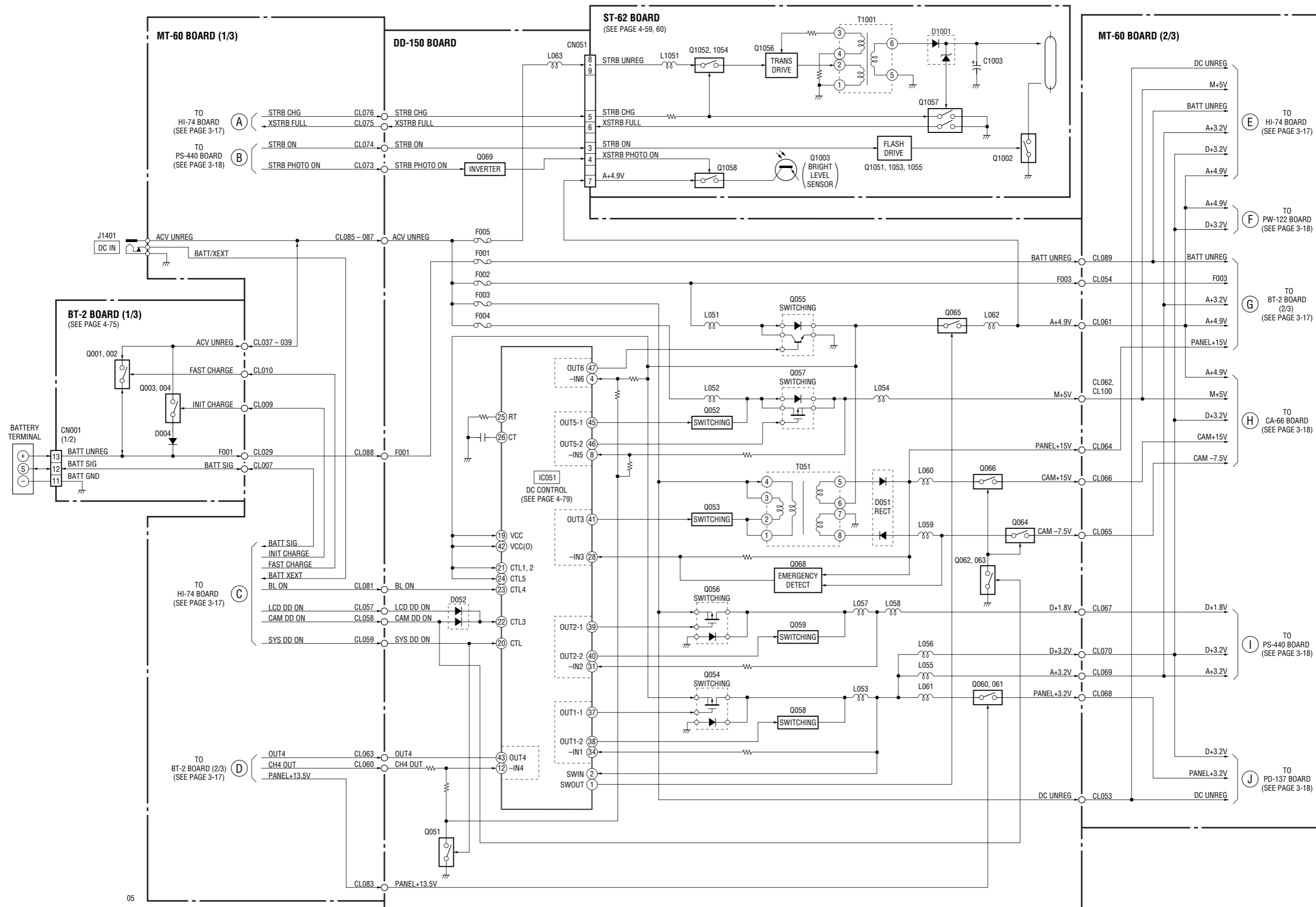

3-9. POWER BLOCK DIAGRAM 2

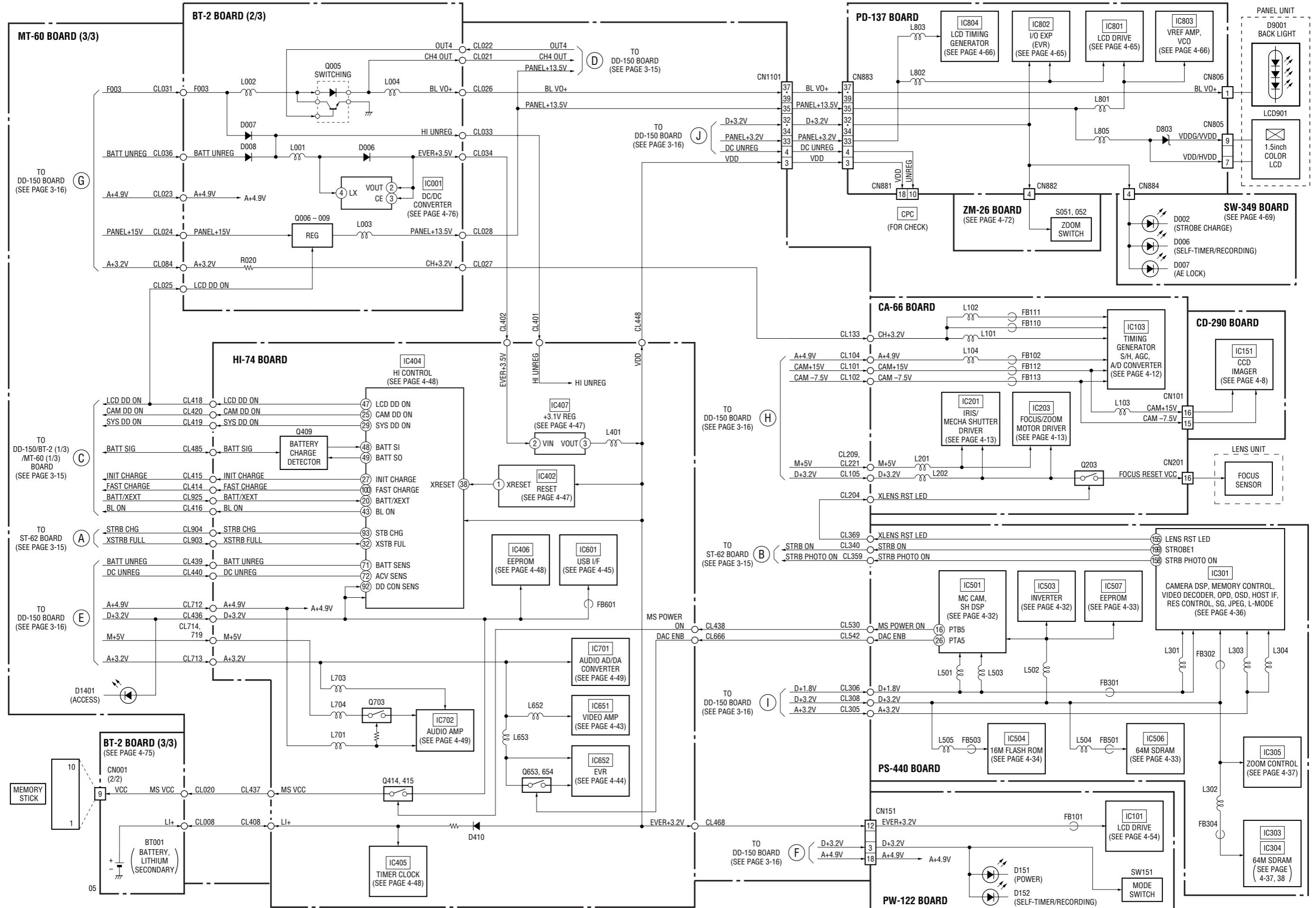

SECTION 4 PRINTED WIRING BOARDS AND SCHEMATIC DIAGRAMS

THIS NOTE IS COMMON FOR WIRING BOARDS AND SCHEMATIC DIAGRAMS

(In addition to this, the necessary note is printed in each block)

(For printed wiring boards)

- : Pattern from the side which enables seeing.
(The other layers' patterns are not indicated)
- Through hole is omitted.
- Circled numbers refer to waveforms.
- There are a few cases that the part printed on diagram isn't mounted in this model.
- Chip parts.

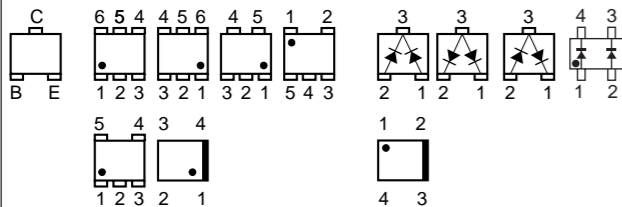

(For schematic diagrams)

- All capacitors are in μF unless otherwise noted. $\text{pF} : \mu\text{F} : \mu\text{F}$. 50 V or less are not indicated except for electrolytics and tantalums.
- Chip resistors are 1/10 W unless otherwise noted. $\text{k}\Omega=1000 \Omega$, $\text{M}\Omega=1000 \text{k}\Omega$.
- Caution when replacing chip parts.
New parts must be attached after removal of chip.
Be careful not to heat the minus side of tantalum capacitor, Because it is damaged by the heat.
- Some chip part will be indicated as follows.

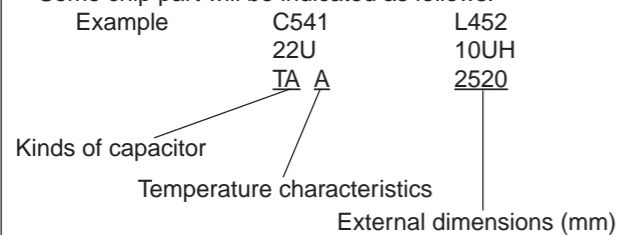

- Constants of resistors, capacitors, ICs and etc with XX indicate that they are not used.
In such cases, the unused circuits may be indicated.
- Parts with \star differ according to the model/destination.
Refer to the mount table for each function.
- All variable and adjustable resistors have characteristic curve B, unless otherwise noted.
- Signal name
XEDIT \rightarrow EDIT PB/XREC \rightarrow PB/REC
- : non flammable resistor
- : fusible resistor
- : panel designation
- : B+ Line *
- : B- Line *
- : IN/OUT direction of (+,-) B LINE. *
- : adjustment for repair. *
- Circled numbers refer to waveforms. *
- * Indicated by the color red.

Note : The components identified by mark Δ or dotted line with mark Δ are critical for safety. Replace only with part number specified.

Note : Les composants identifiés par une marque Δ sont critiques pour la sécurité. Ne les remplacer que par une pièce portant le numéro spécifiée.

(Measuring conditions voltage and waveform)

- Voltages and waveforms are measured between the measurement points and ground when camera shoots color bar chart of pattern box. They are reference values and reference waveforms. *
- (VOM of DC 10 $\text{M}\Omega$ input impedance is used)
- Voltage values change depending upon input impedance of VOM used.)

1. Connection

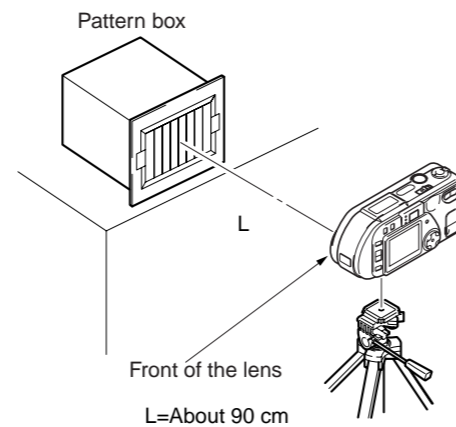

2. Adjust the distance so that the output waveform of Fig. a and the Fig. b can be obtain.

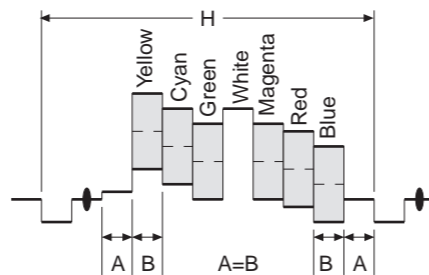

Fig. a (Video output terminal output waveform)

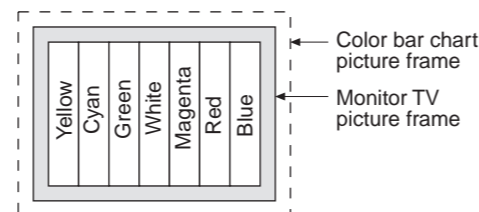
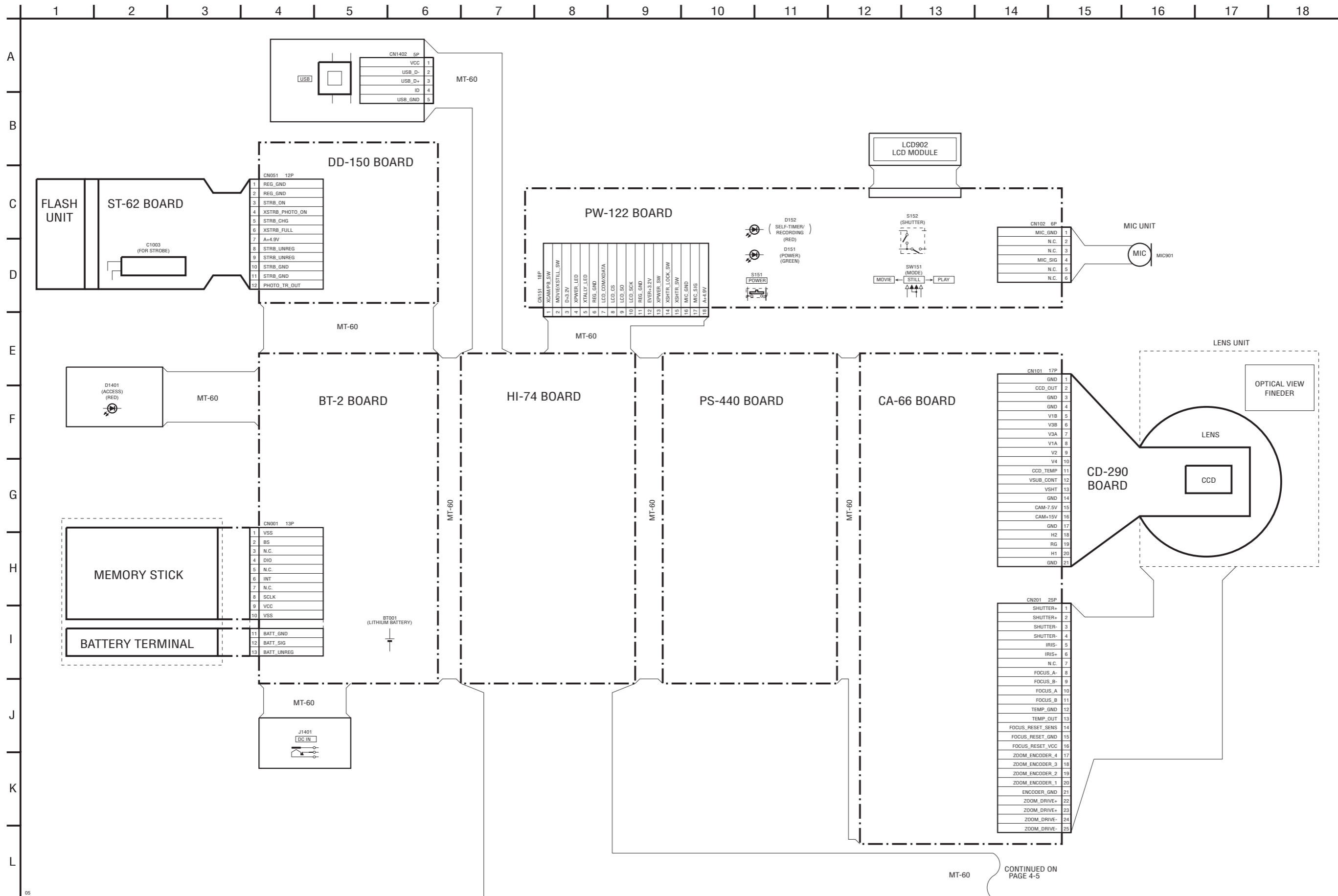

Fig.b (Picture on monitor TV)

When indicating parts by reference number, please include the board name.

4-1. FRAME SCHEMATIC DIAGRAMS

FRAME SCHEMATIC DIAGRAM (1/2)



MT-60 CONTINUED ON PAGE 4-5

FRAME SCHEMATIC DIAGRAM (2/2)

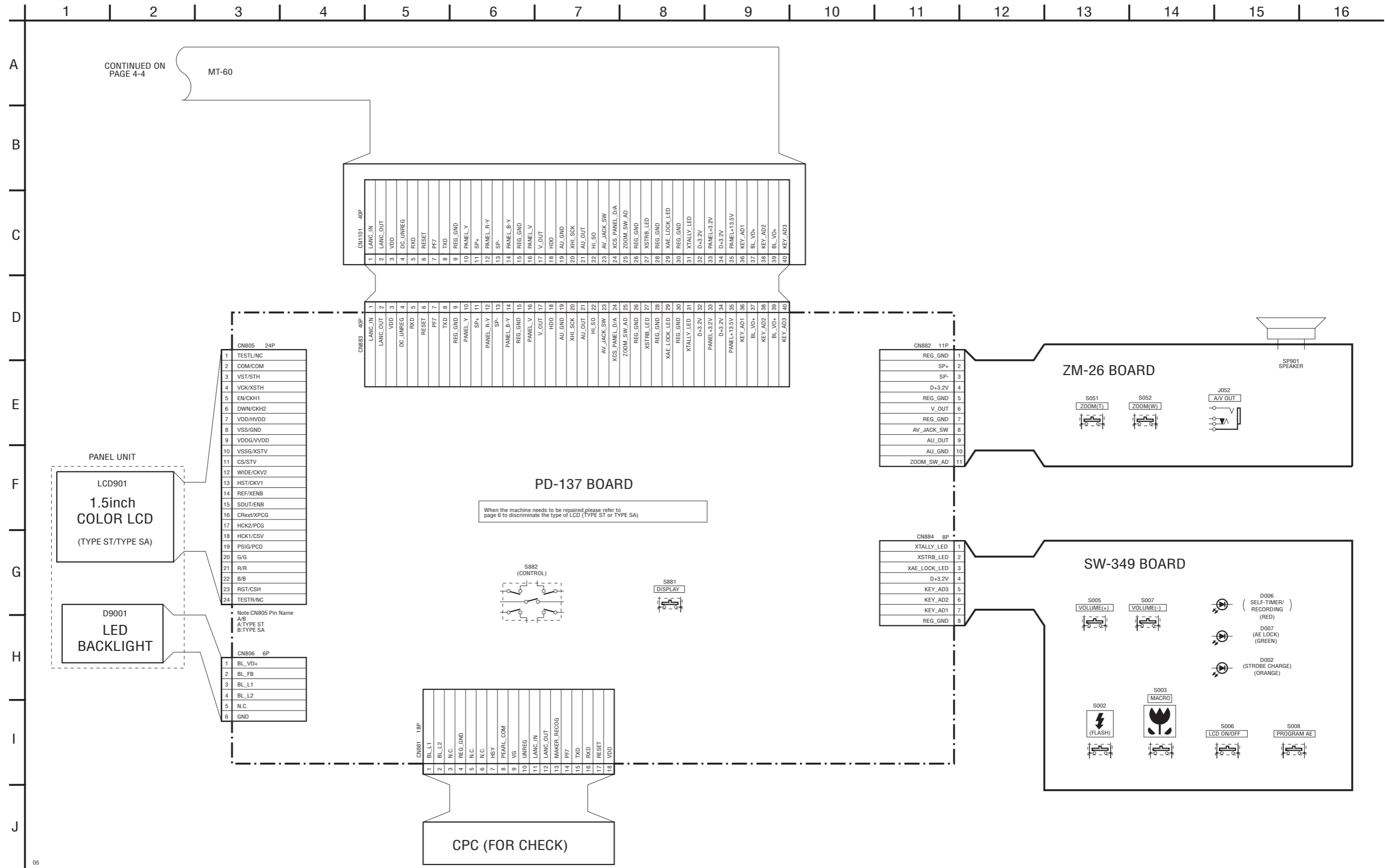

05

4-2. PRINTED WIRING BOARDS AND SCHEMATIC DIAGRAMS

CD-290 (CCD IMAGER) PRINTED WIRING BOARD AND SCHEMATIC DIAGRAM

– Ref. No.: CD-290 board; 20,000 series –

- For Printed Wiring Board.
- There are a few cases that the part isn't mounted in this model is printed on this diagram.
- Chip parts

Transistor



CD-290 BOARD (SIDE A)

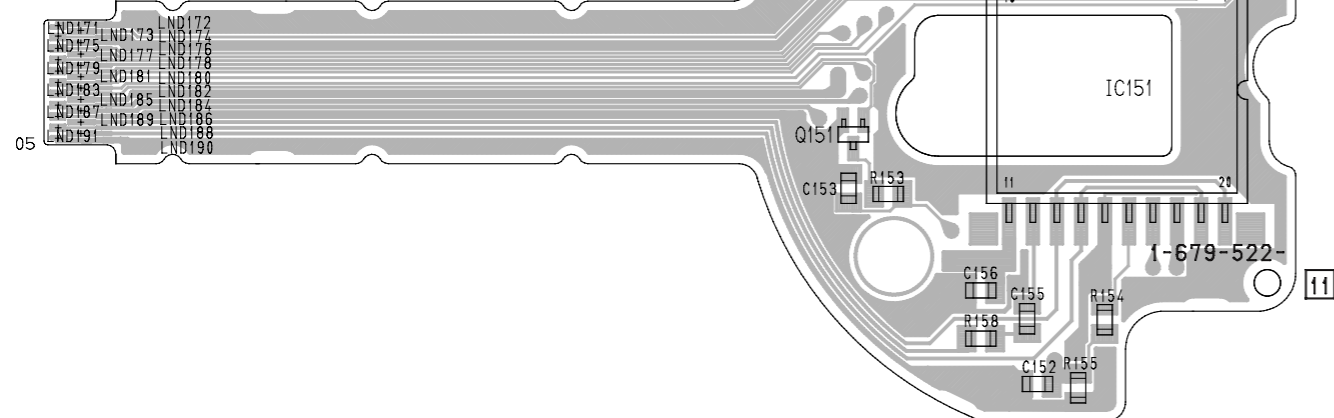

CD-290 BOARD (SIDE B)

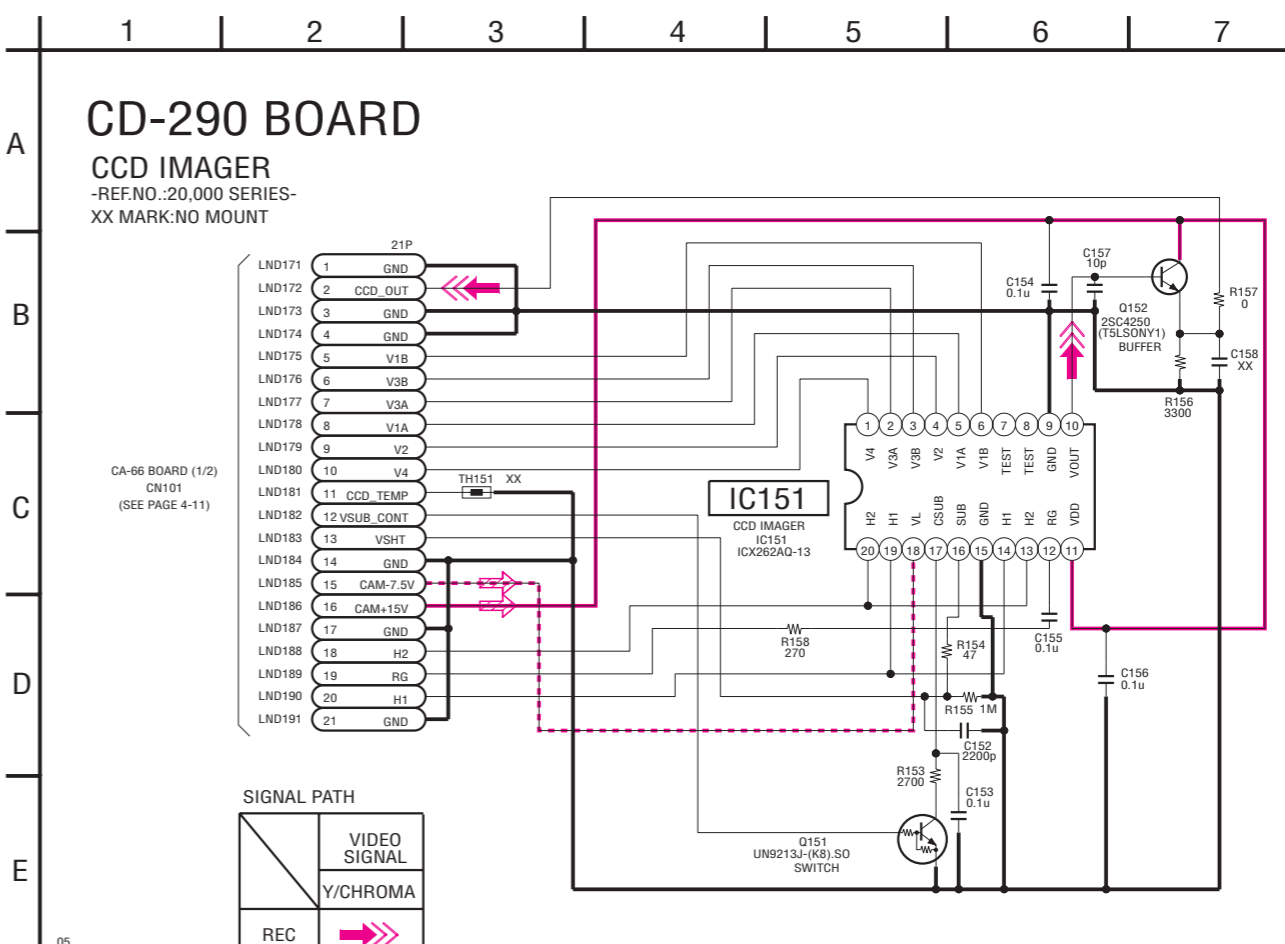
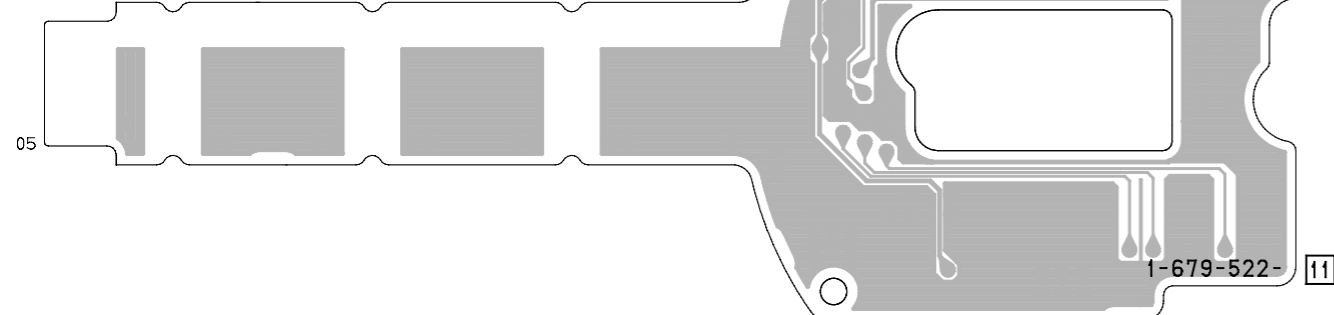

Precautions for Replacement of CCD Imager

- The CD-290 board mounted as a repair part is not equipped with a CCD imager. When replacing this board, remove the CCD imager from the old one and mount it onto the new one.
- If the CCD imager has been replaced, carry out all the adjustments for the camera section.
- As the CCD imager may be damaged by static electricity from its structure, handle it carefully like for the MOS IC. In addition, ensure that the receiver is not covered with dusts nor exposed to strong light.

PW-122 (LCD DRIVER) PRINTED WIRING BOARD

- Ref. No.: PW-122 board; 30,000 series -

- For Printed Wiring Board.
- There are a few cases that the part isn't mounted in this model is printed on this diagram.
- See page 4-85 for printed parts location.

PW-122 BOARD (SIDE A)

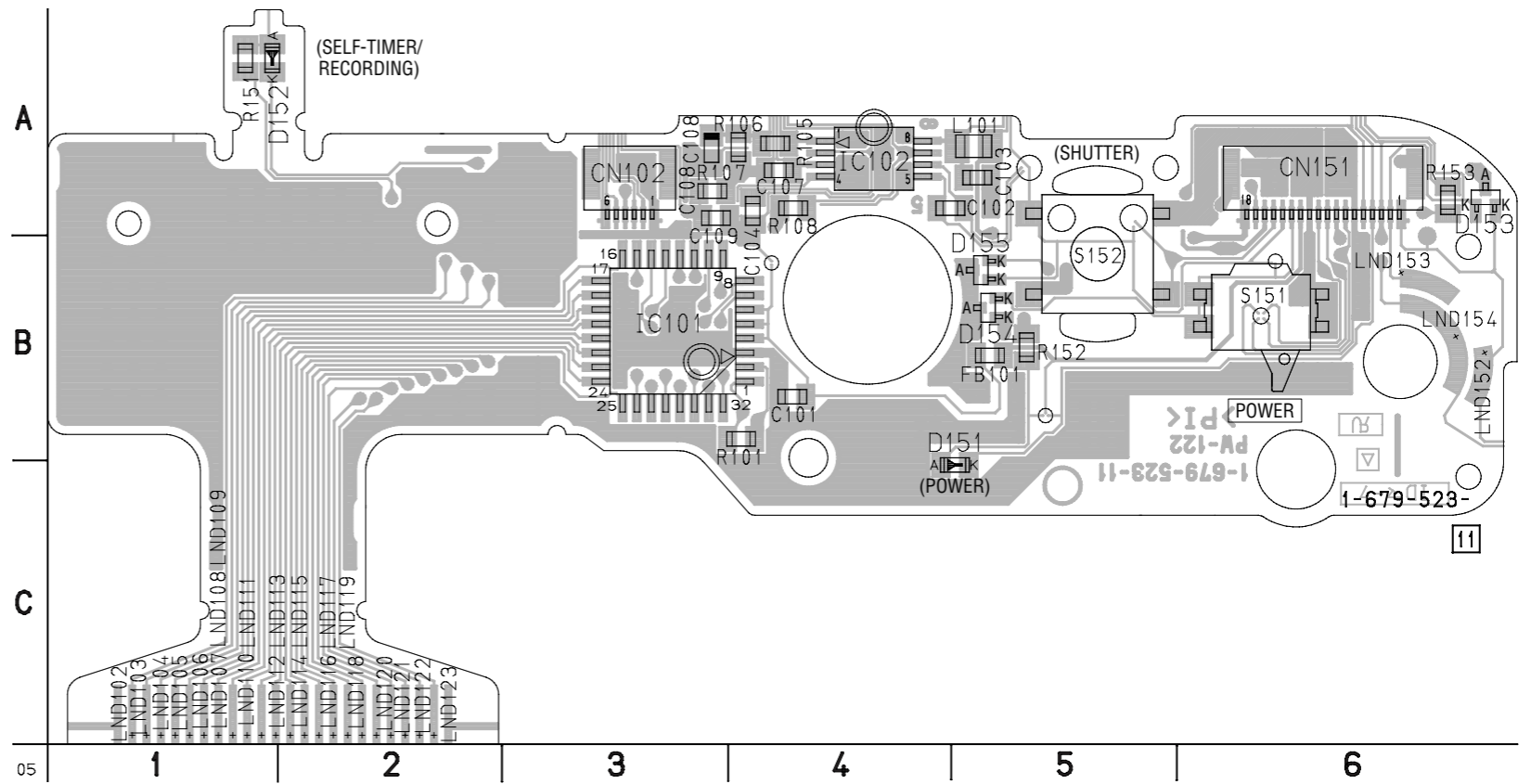

PW-122 BOARD (SIDE B)

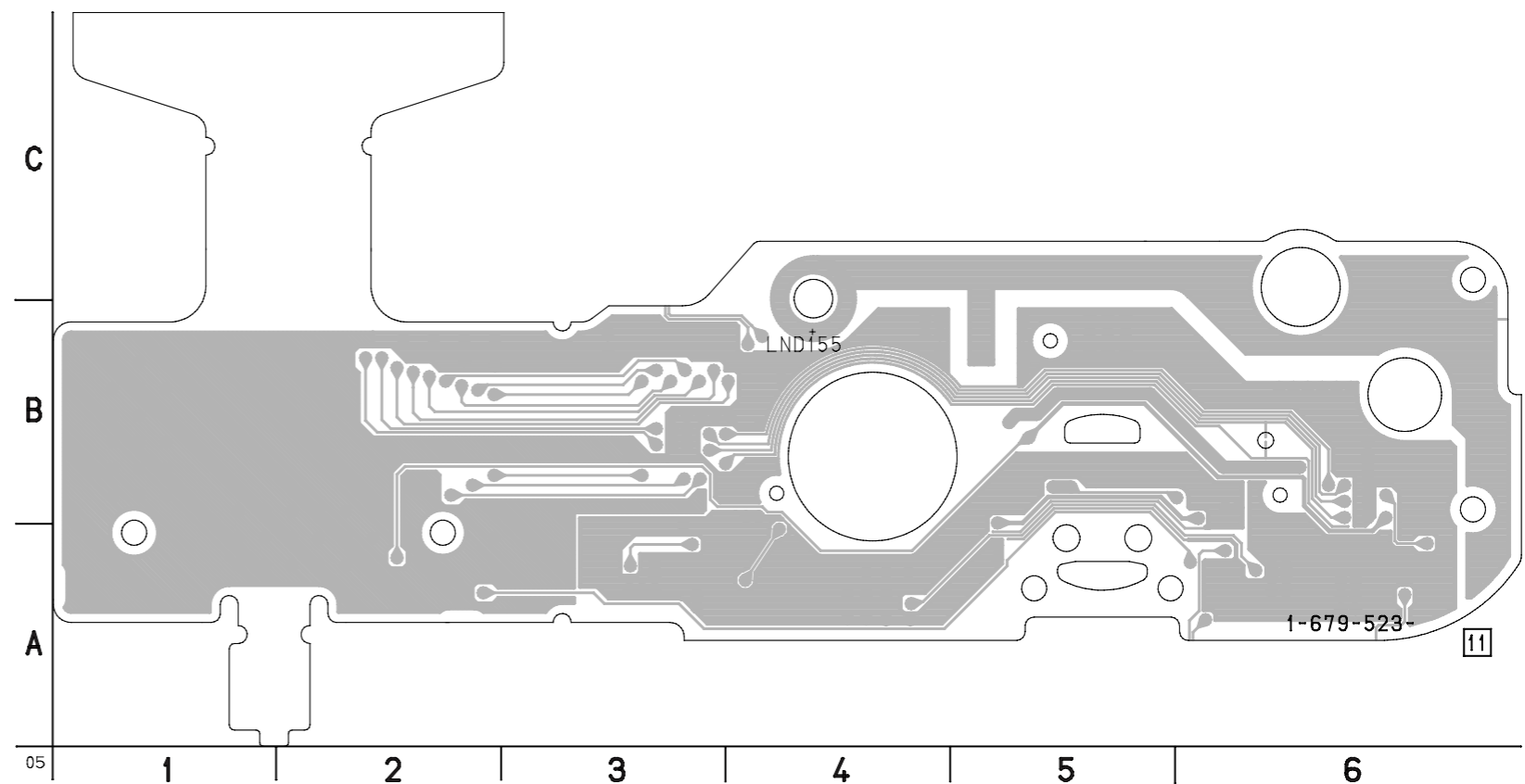

PW-122 (LCD DRIVER) SCHEMATIC DIAGRAM

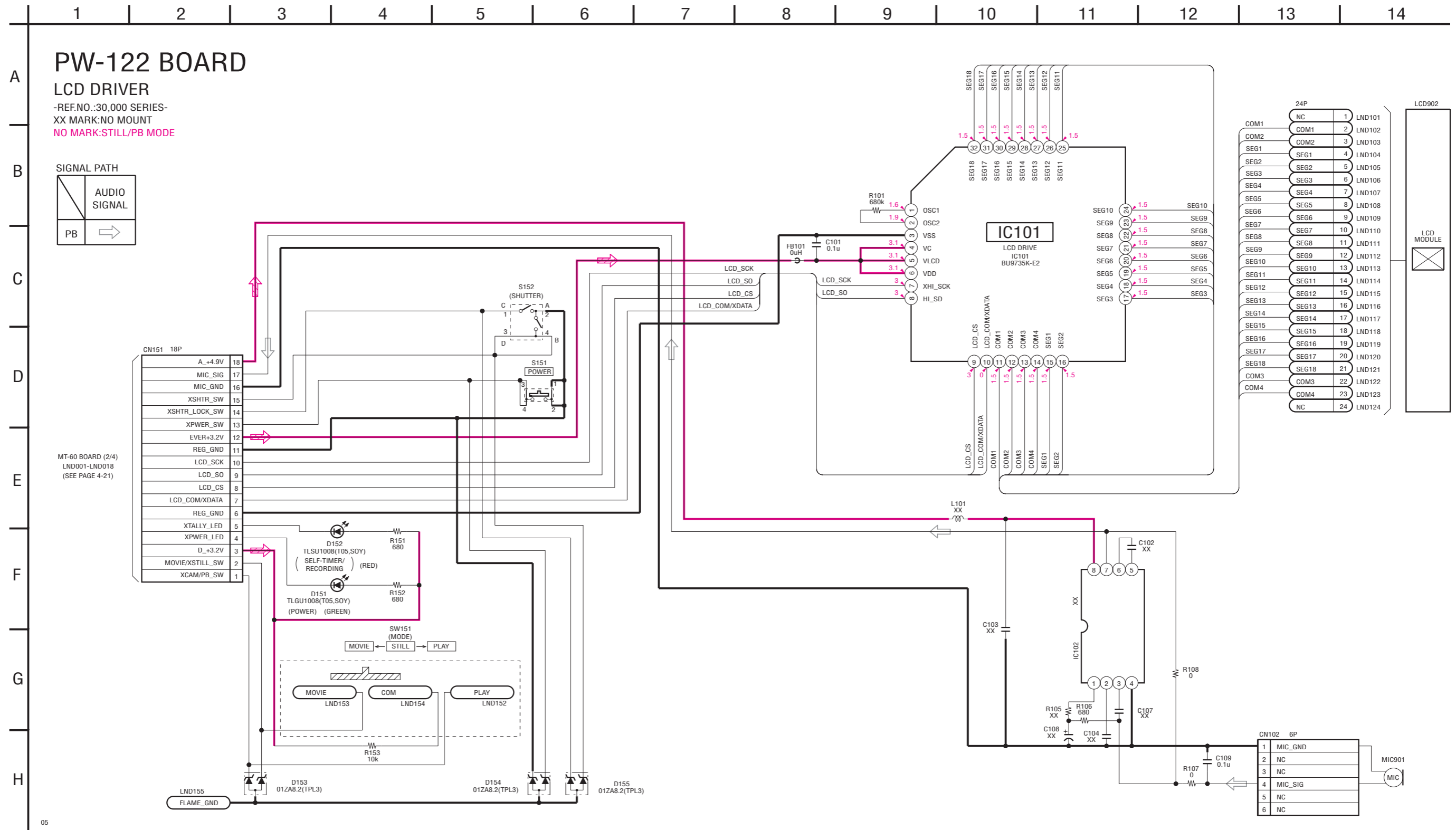

05

ST-62 (STROBE) PRINTED WIRING BOARD

- Ref. No.: ST-62 board; 10,000 series -

- For Printed Wiring Board.
- There are a few cases that the part isn't mounted in this model is printed on this diagram.
- See page 4-85 for printed parts location.
- Chip parts

Transistor

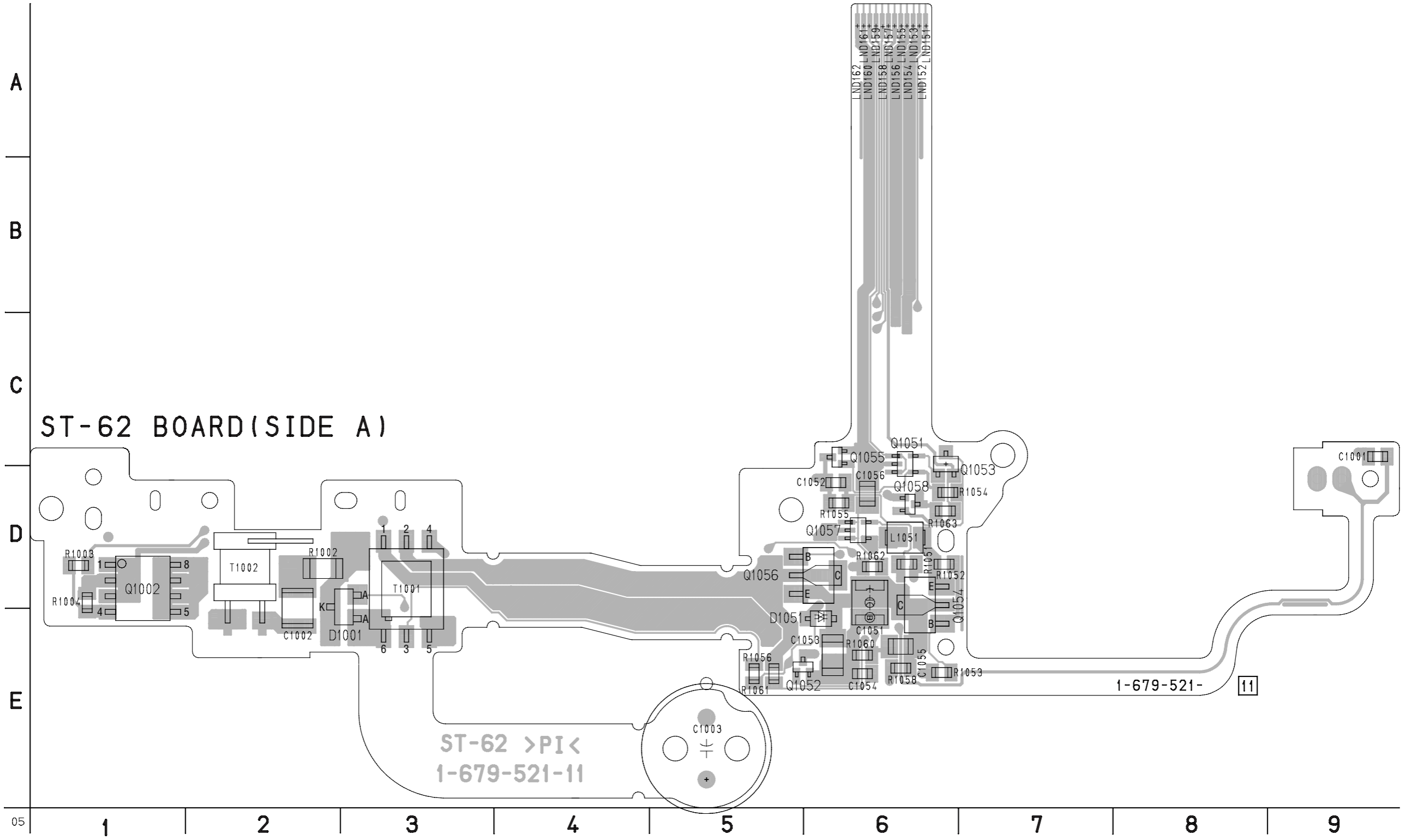
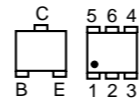

ST-62 BOARD (SIDE B)

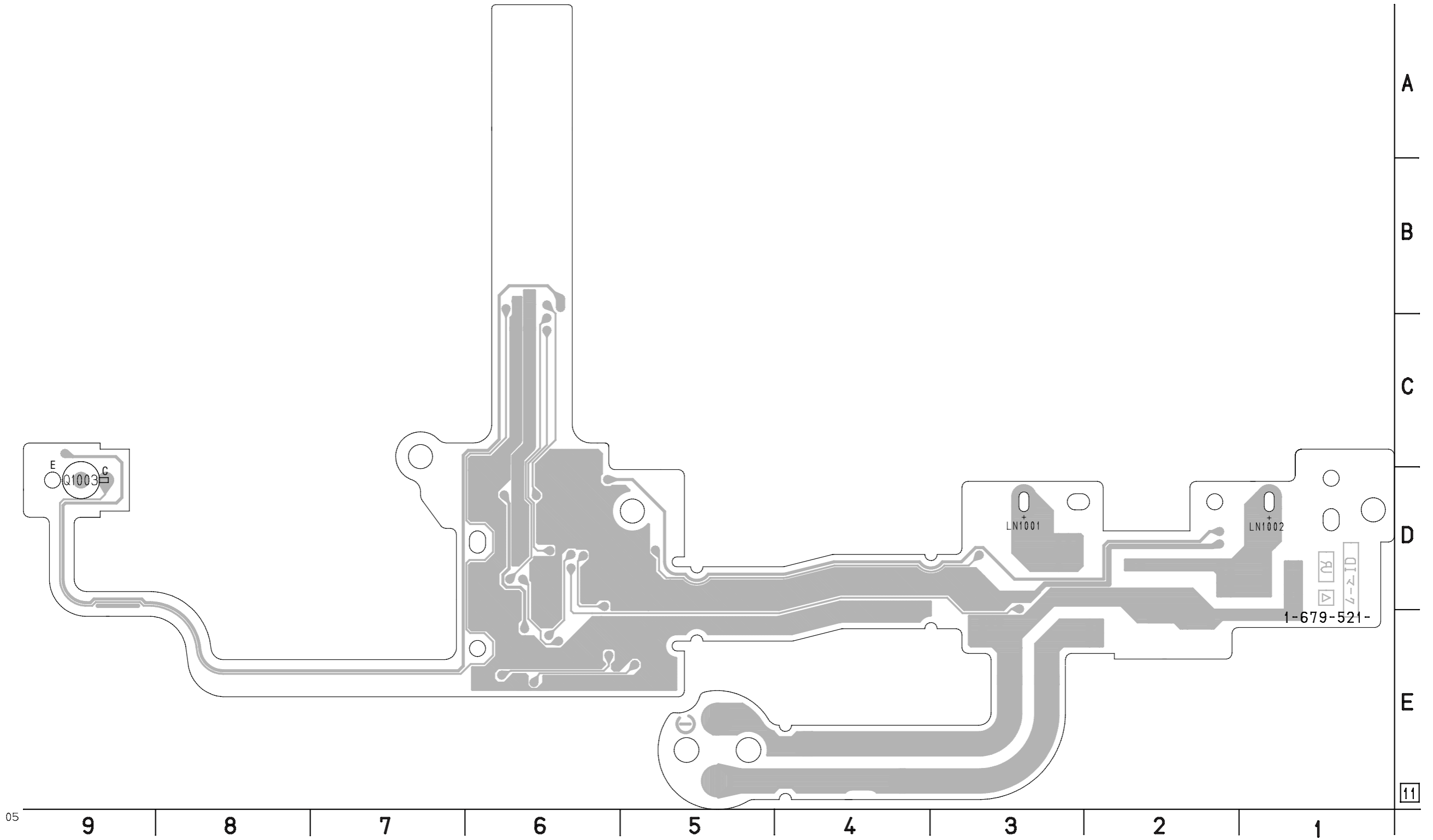

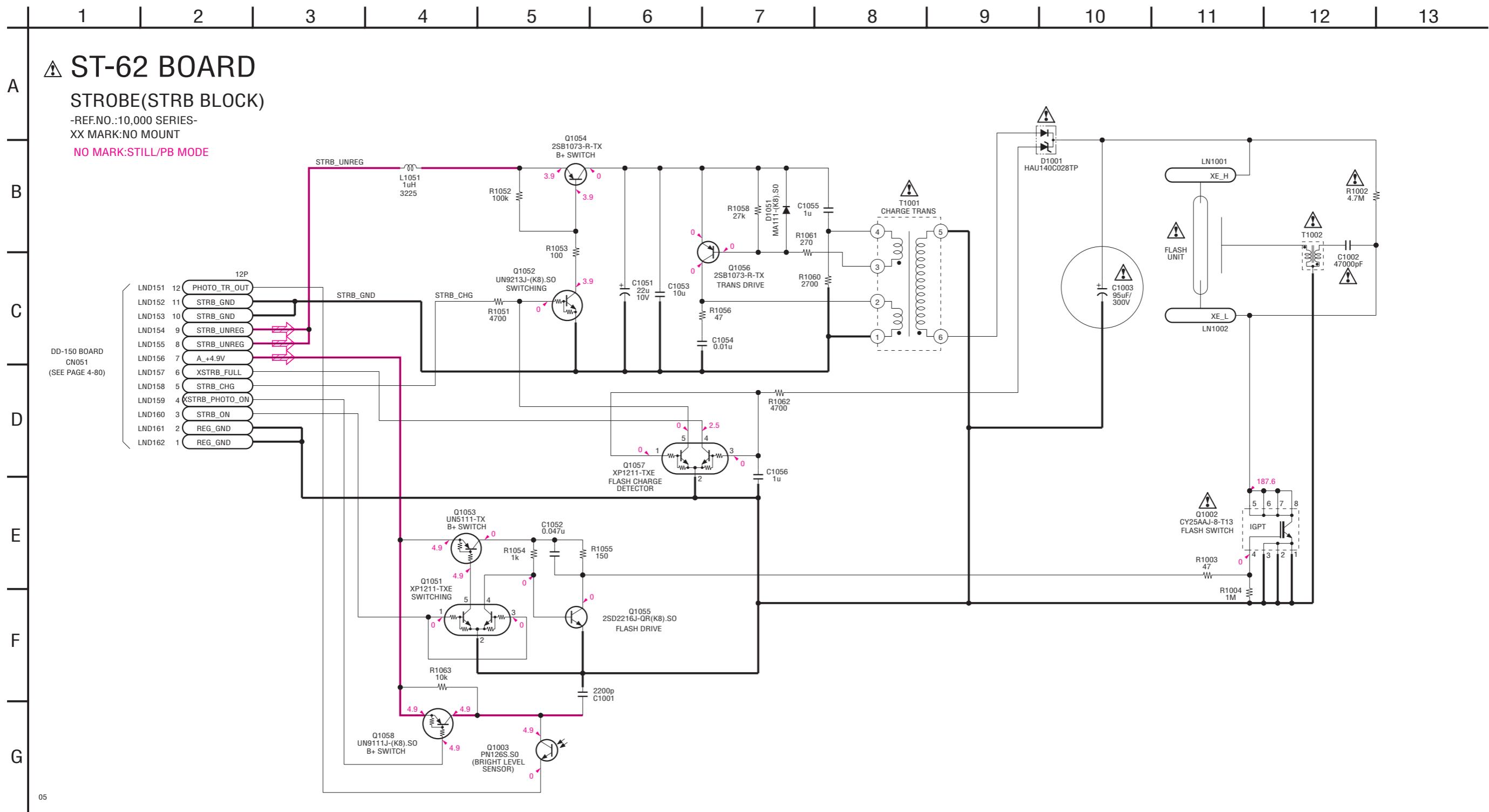

The components identified by mark \triangle or dotted line with mark \triangle are critical for safety. Replace only with part number specified.

Les composants identifiés par une marque \triangle sont critiques pour la sécurité. Ne les remplacer que par une pièce portant le numéro spécifié.

PD-137 (CONNECTION, LCD DRIVE, TIMING GENERATOR) PRINTED WIRING BOARD

– Ref. No.: PD-137 board; 10,000 series –

- For Printed Wiring Board.
- PD-137 board is four-layer print board. However, the patterns of layers 2 to 3 have not been included in the diagram.
- There are a few cases that the part isn't mounted in this model is printed on this diagram.
- See page 4-85 for printed parts location.
- Chip parts

Transistor

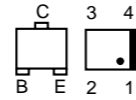

PD-137 BOARD (SIDE A)

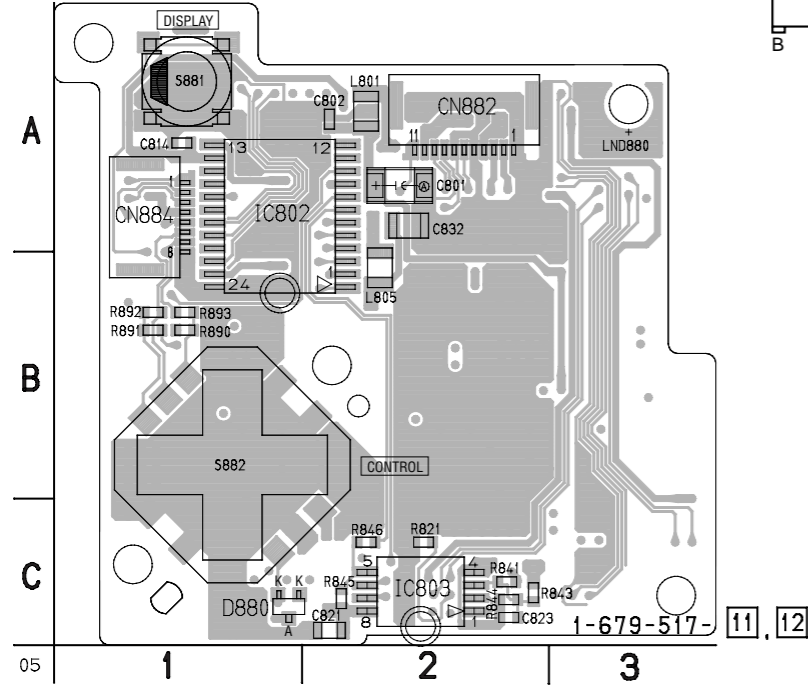

PD-137 BOARD (SIDE B)

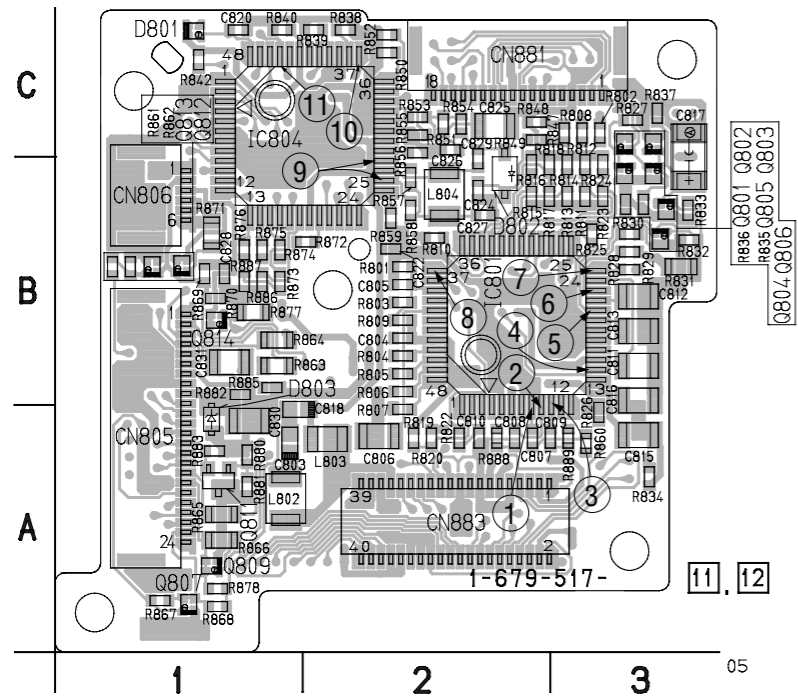

PD-137 (CONNECTION) SCHEMATIC DIAGRAM • See page 4-61 for PD-137 printed wiring board.

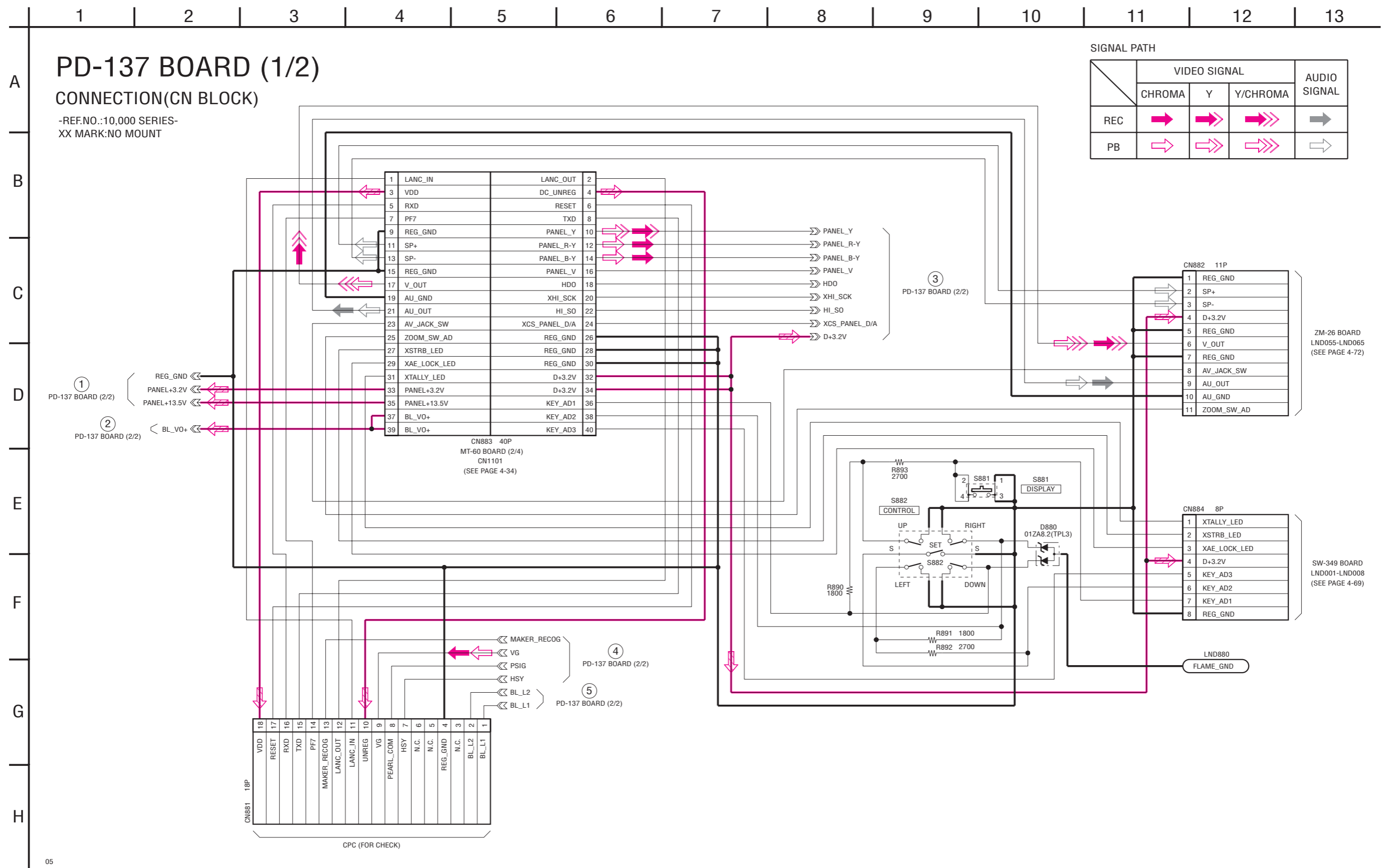

PD-137 (LCD DRIVE, TIMING GENERATOR) SCHEMATIC DIAGRAM • See page 4-61 for PD-137 printed wiring board. • See page 4-82 for waveforms.

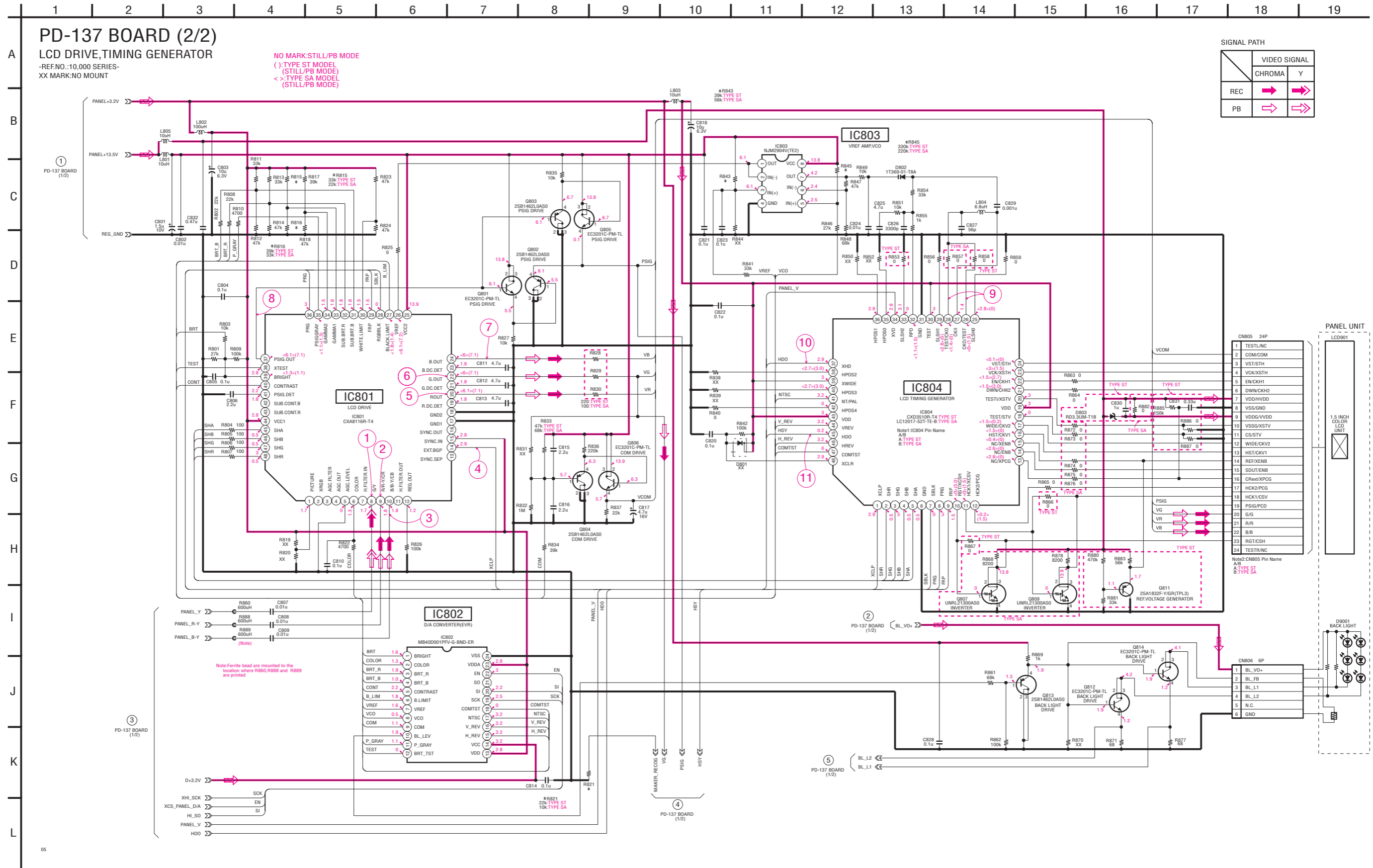

SW-349 (CONTROL SWITCH) PRINTED WIRING BOARD

– Ref. No.: SW-349 board; 20,000 series –

- For Printed Wiring Board.
- There are a few cases that the part isn't mounted in this model is printed on this diagram.
- See page 4-85 for printed parts location.

SW-349 BOARD (SIDE A)

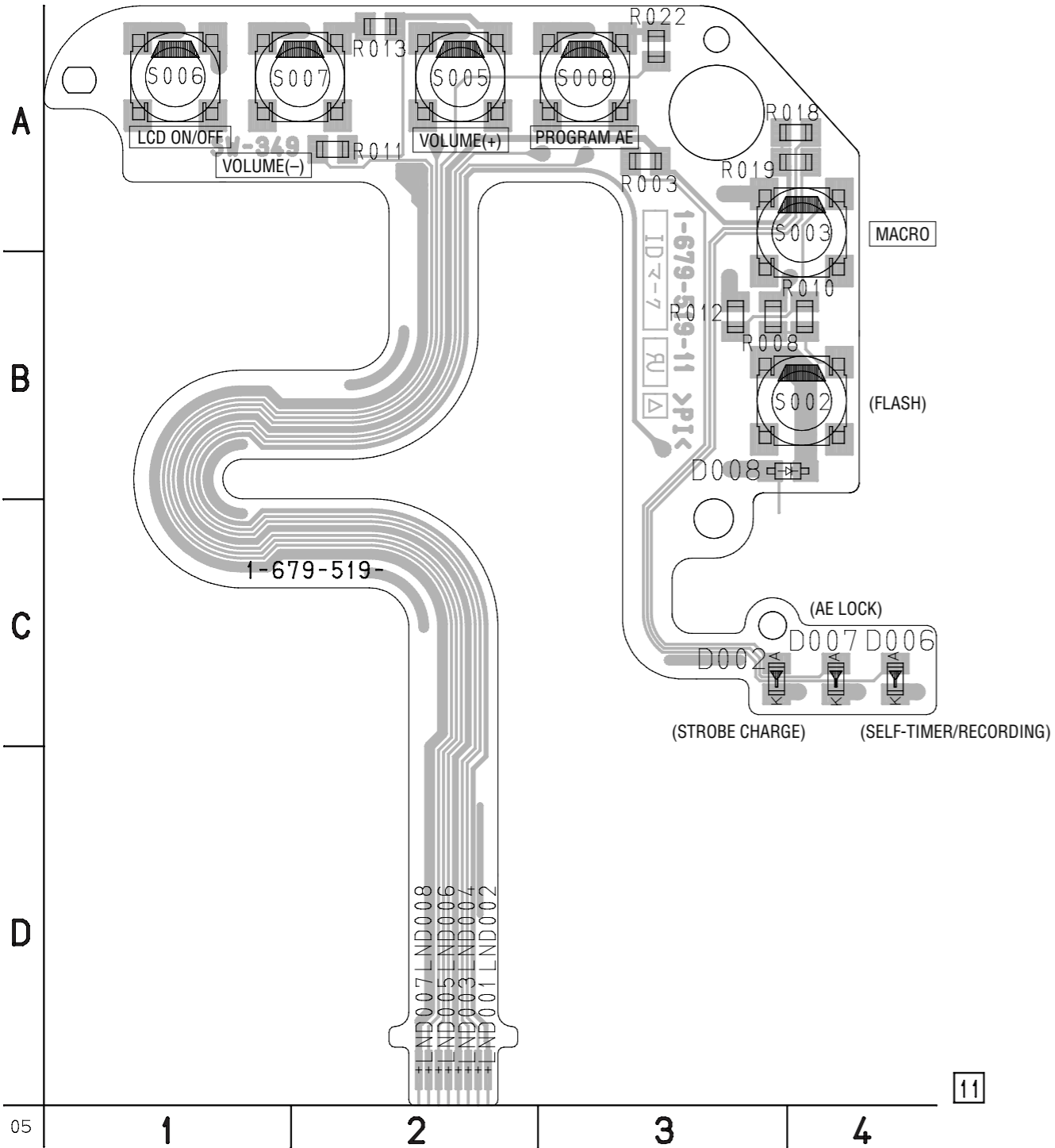

SW-349 BOARD (SIDE B)

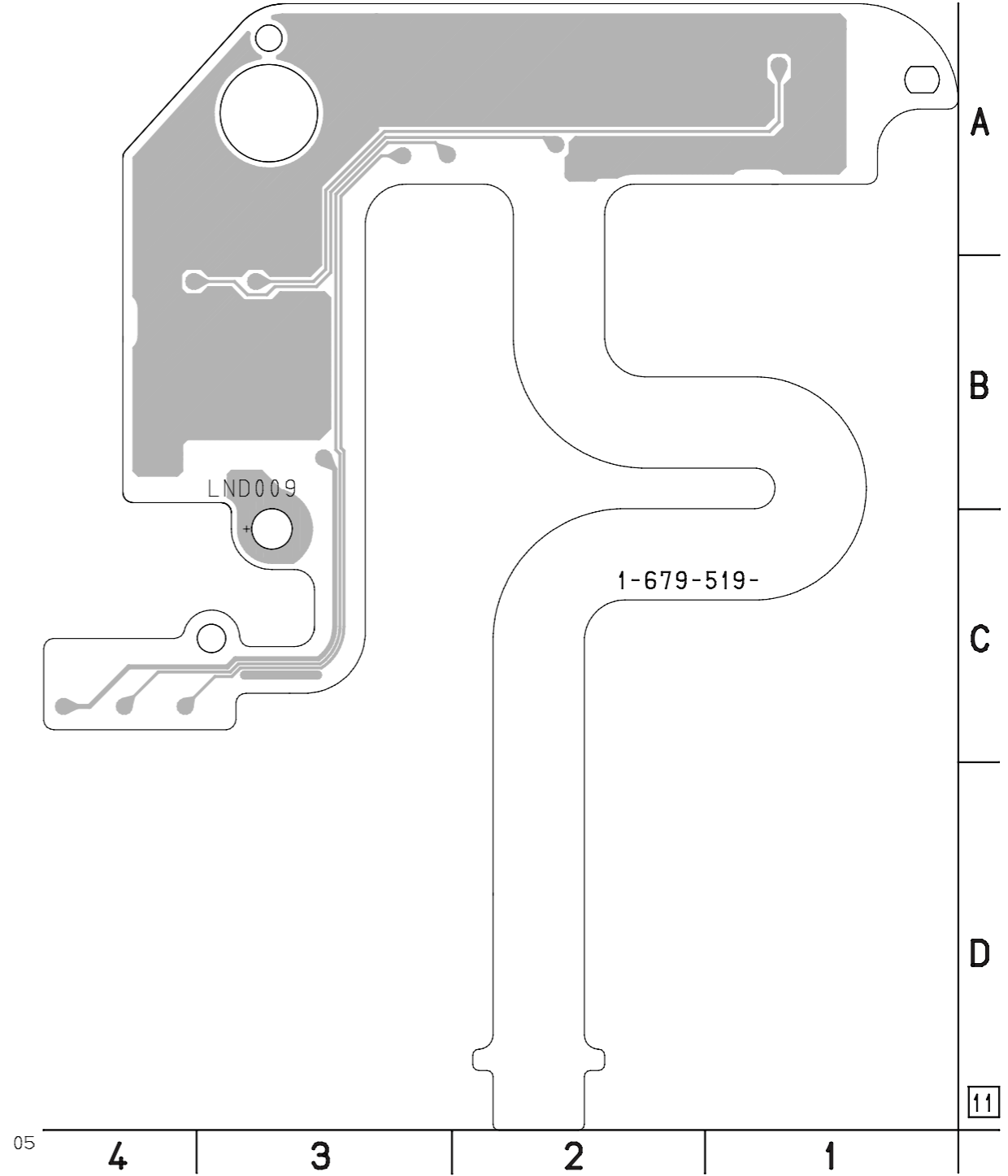

SW-349 (CONTROL SWITCH) SCHEMATIC DIAGRAM

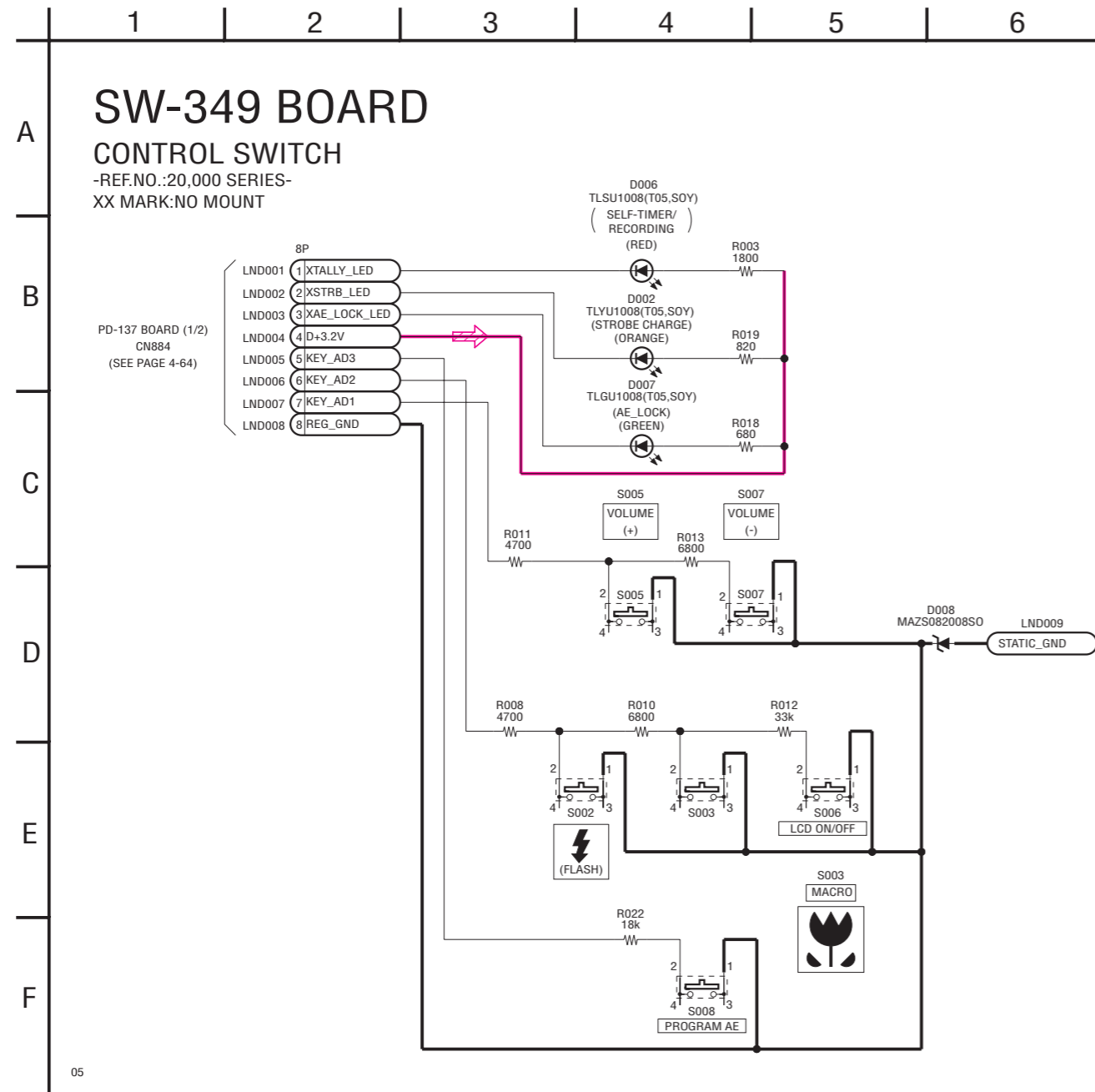

05

ZM-26 (ZOOM SWITCH) PRINTED WIRING BOARD AND SCHEMATIC DIAGRAM

– Ref. No.: ZM-26 board; 20,000 series –

- For Printed Wiring Board.
- There are a few cases that the part isn't mounted in this model is printed on this diagram.

ZM-26 BOARD (SIDE A)

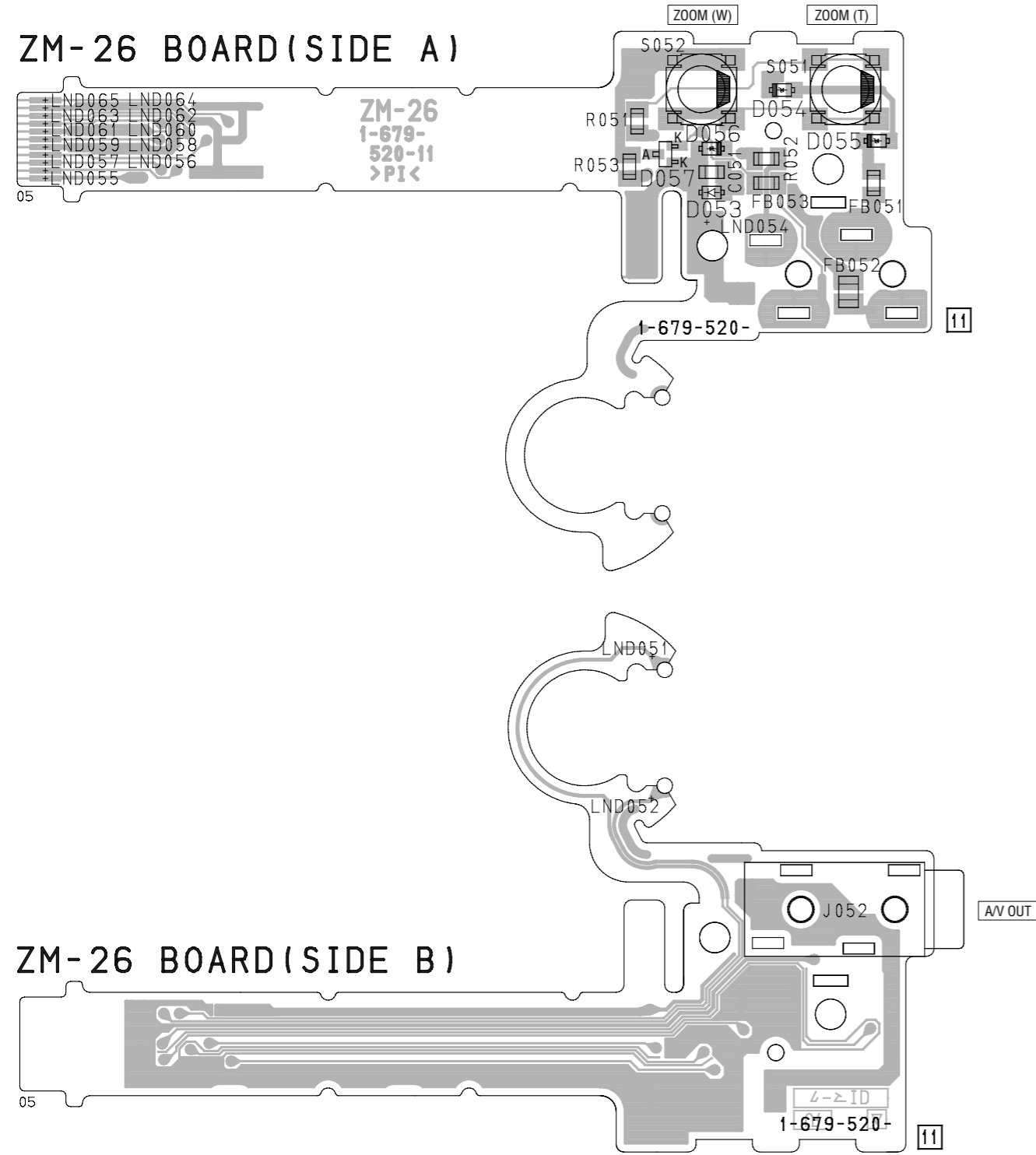

ZM-26 BOARD (SIDE B)

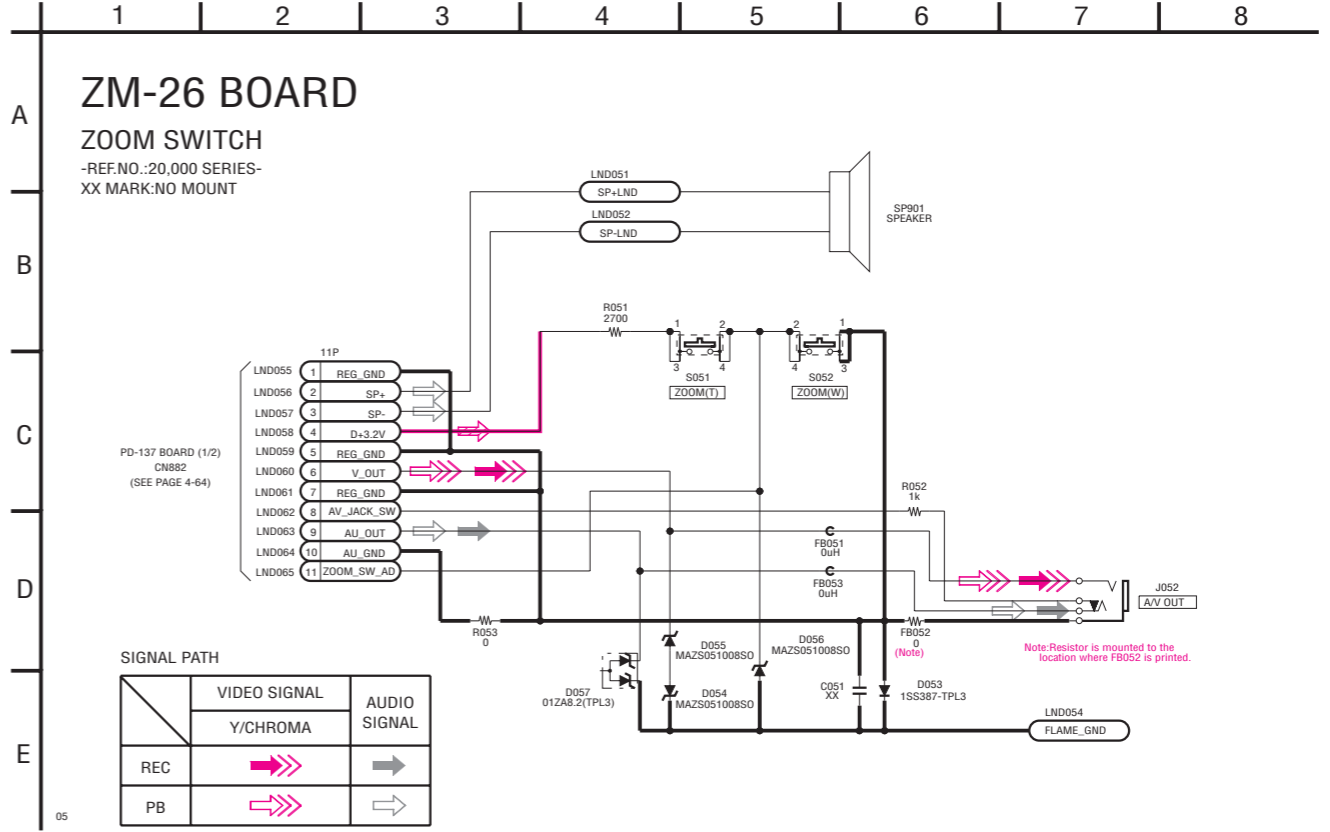
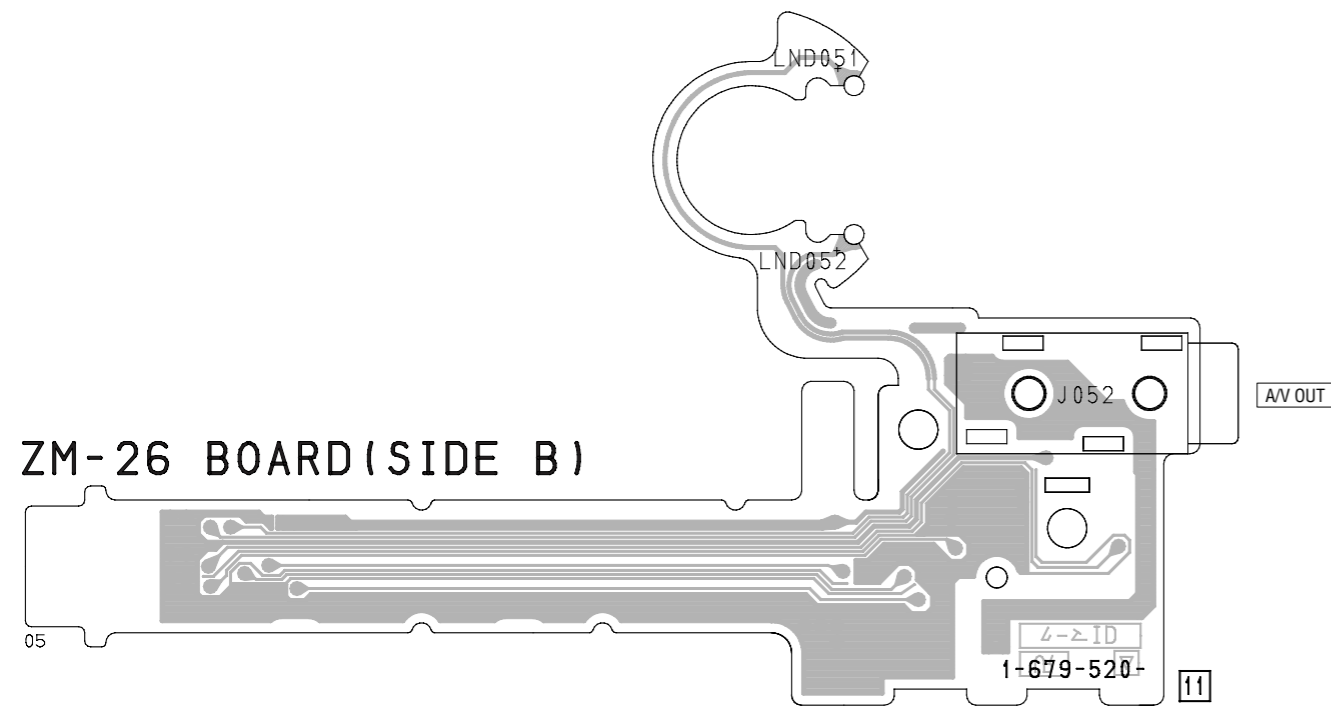

4-3. WAVEFORMS

PD-137 BOARD

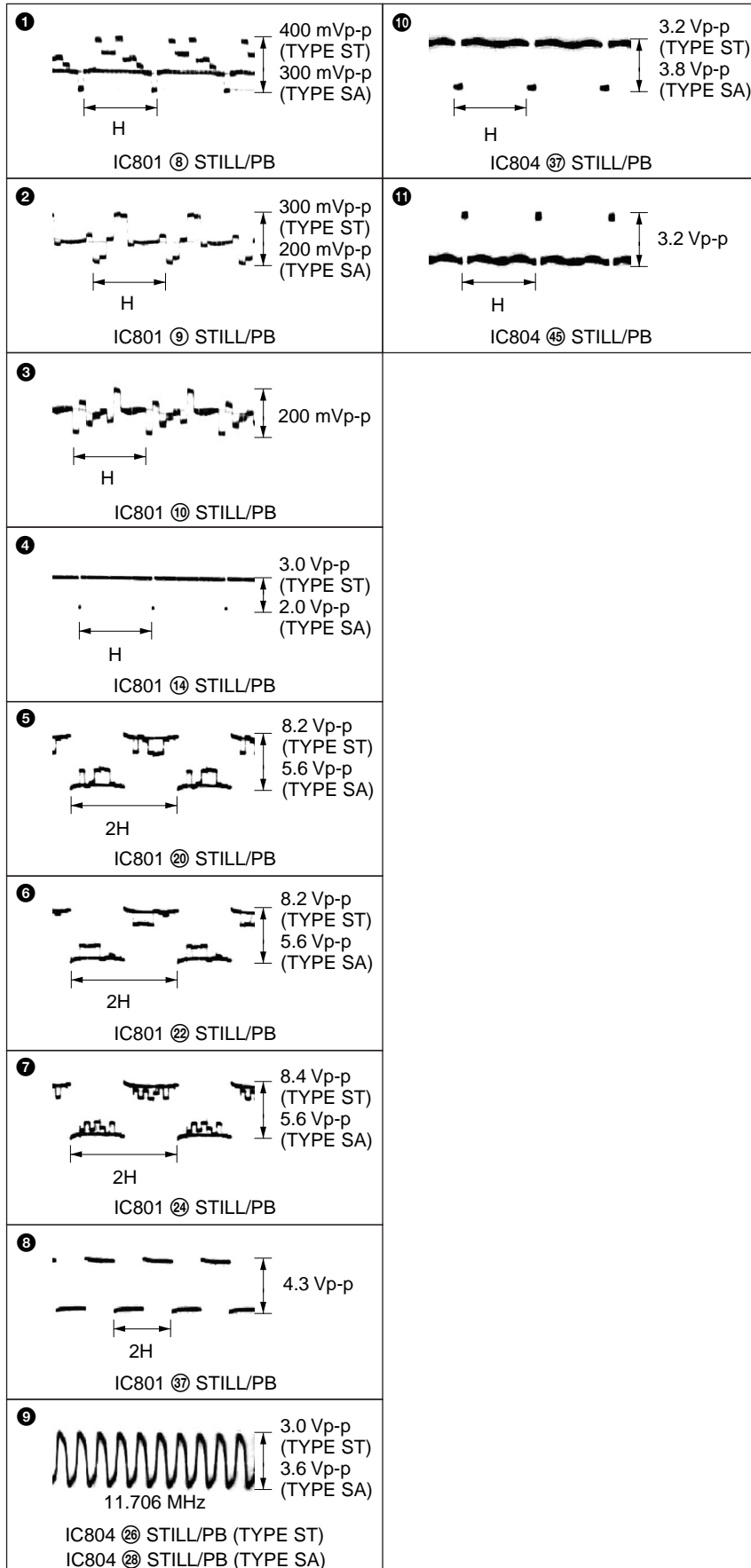

4-4. PARTS LOCATION

| PW-122 BOARD (SIDE A) | | ST-62 BOARD (SIDE A) | | ST-62 BOARD (SIDE B) | | PD-137 BOARD (SIDE A) | | PD-137 BOARD (SIDE B) | | SW-349 BOARD (SIDE A) | | | |
|--------------------------|-----|-------------------------|-----|-------------------------|-----|--------------------------|-----|--------------------------|-----|--------------------------|-----|------|-----|
| C101 | B-4 | C1001 | D-9 | Q1003 | D-9 | C801 | A-2 | C803 | A-1 | R854 | C-2 | D002 | C-3 |
| C109 | A-3 | C1002 | E-2 | | | C802 | A-2 | C804 | B-2 | R855 | C-2 | D006 | C-4 |
| | | C1003 | E-5 | | | C814 | A-1 | C805 | B-2 | R856 | B-2 | D007 | C-4 |
| CN102 | A-3 | C1051 | E-6 | | | C821 | C-2 | C806 | A-2 | R857 | B-2 | D008 | B-3 |
| CN151 | A-6 | C1052 | D-6 | | | C823 | C-3 | C807 | A-2 | R858 | B-2 | | |
| | | C1053 | E-6 | | | C832 | A-2 | C808 | A-2 | R859 | B-2 | R003 | A-3 |
| D151 | B-5 | C1054 | E-6 | | | | | C809 | A-2 | R860 | A-3 | R008 | B-3 |
| D152 | A-1 | C1055 | E-6 | | | CN882 | A-2 | C810 | A-2 | R861 | B-1 | R010 | B-4 |
| D153 | A-6 | C1056 | D-6 | | | CN884 | A-1 | C811 | B-3 | R862 | B-1 | R011 | A-2 |
| D154 | B-5 | | | | | | | C812 | B-3 | R863 | B-1 | R012 | B-3 |
| D155 | B-5 | D1001 | E-3 | | | D880 | C-1 | C813 | B-3 | R864 | B-1 | R013 | A-2 |
| | | D1051 | E-5 | | | | | C815 | A-3 | R865 | A-1 | R018 | A-4 |
| FB101 | B-5 | | | | | IC802 | A-1 | C816 | A-3 | R866 | A-1 | R019 | A-4 |
| | | L1051 | D-6 | | | IC803 | C-2 | C817 | C-3 | R867 | A-1 | R022 | A-3 |
| IC101 | B-3 | | | | | | | C818 | A-2 | R868 | A-1 | | |
| | | Q1002 | D-1 | | | L801 | A-2 | C820 | C-1 | R869 | B-1 | S002 | B-4 |
| R101 | B-4 | Q1051 | D-6 | | | L805 | B-2 | C822 | B-2 | R871 | B-1 | S003 | A-4 |
| R106 | A-4 | Q1052 | E-6 | | | | | C824 | B-2 | R872 | B-2 | S005 | A-2 |
| R107 | A-3 | Q1053 | D-7 | | | R821 | C-2 | C825 | C-2 | R873 | B-1 | S006 | A-1 |
| R108 | A-4 | Q1054 | D-6 | | | R841 | C-2 | C826 | B-2 | R874 | B-1 | S007 | A-2 |
| R151 | A-1 | Q1055 | D-6 | | | R843 | C-2 | C827 | B-2 | R875 | B-1 | S008 | A-3 |
| R152 | B-5 | Q1056 | D-5 | | | R845 | C-2 | C828 | B-1 | R876 | B-1 | | |
| R153 | A-6 | Q1057 | D-6 | | | R846 | C-2 | C829 | B-2 | R877 | B-1 | | |
| | | Q1058 | D-6 | | | R890 | B-1 | C830 | A-1 | R878 | A-1 | | |
| S151 | B-6 | | | | | R891 | B-1 | C831 | B-1 | R880 | A-1 | | |
| S152 | B-5 | | | | | R892 | B-1 | | | R881 | A-1 | | |
| | | R1002 | D-2 | | | R893 | B-1 | CN805 | A-1 | R882 | B-1 | | |
| | | R1003 | D-1 | | | | | CN806 | B-1 | R883 | A-1 | | |
| | | R1004 | D-1 | | | | | CN881 | C-2 | R885 | B-1 | | |
| | | R1051 | D-6 | | | S881 | A-1 | CN883 | A-2 | R886 | B-1 | | |
| | | R1052 | D-6 | | | S882 | B-1 | | | R887 | B-1 | | |
| | | R1053 | E-7 | | | | | D802 | B-2 | R888 | A-2 | | |
| | | R1054 | D-7 | | | | | D803 | A-1 | R889 | A-3 | | |
| | | R1055 | D-6 | | | | | | | | | | |
| | | R1056 | E-5 | | | | | IC801 | B-2 | | | | |
| | | R1058 | E-6 | | | | | IC804 | C-1 | | | | |
| | | R1060 | E-6 | | | | | | | | | | |
| | | R1061 | E-5 | | | | | L802 | A-1 | | | | |
| | | R1062 | D-6 | | | | | L803 | A-2 | | | | |
| | | R1063 | D-6 | | | | | L804 | B-2 | | | | |
| | | T1001 | D-3 | | | | | | | | | | |
| | | T1002 | D-2 | | | | | Q801 | B-3 | | | | |
| | | | | | | | | Q802 | C-3 | | | | |
| | | | | | | | | Q803 | C-3 | | | | |
| | | | | | | | | Q804 | B-3 | | | | |
| | | | | | | | | Q805 | B-3 | | | | |
| | | | | | | | | Q807 | A-1 | | | | |
| | | | | | | | | Q809 | A-1 | | | | |
| | | | | | | | | Q806 | B-3 | | | | |
| | | | | | | | | Q811 | A-1 | | | | |
| | | | | | | | | Q812 | B-1 | | | | |
| | | | | | | | | Q813 | B-1 | | | | |
| | | | | | | | | Q814 | B-1 | | | | |
| | | | | | | | | | | | | | |
| | | | | | | | | R801 | B-2 | | | | |
| | | | | | | | | R802 | C-3 | | | | |
| | | | | | | | | R803 | B-2 | | | | |
| | | | | | | | | R804 | B-2 | | | | |
| | | | | | | | | R805 | B-2 | | | | |
| | | | | | | | | R806 | B-2 | | | | |
| | | | | | | | | R807 | A-2 | | | | |
| | | | | | | | | R808 | C-3 | | | | |
| | | | | | | | | R809 | B-2 | | | | |
| | | | | | | | | R810 | B-2 | | | | |
| | | | | | | | | R811 | B-3 | | | | |
| | | | | | | | | R812 | B-3 | | | | |
| | | | | | | | | R813 | B-3 | | | | |
| | | | | | | | | R814 | B-3 | | | | |
| | | | | | | | | R815 | B-2 | | | | |
| | | | | | | | | R816 | B-2 | | | | |
| | | | | | | | | R817 | B-2 | | | | |
| | | | | | | | | R818 | B-2 | | | | |
| | | | | | | | | R822 | A-2 | | | | |
| | | | | | | | | R823 | B-3 | | | | |
| | | | | | | | | R824 | B-3 | | | | |
| | | | | | | | | R825 | B-3 | | | | |
| | | | | | | | | R826 | A-3 | | | | |
| | | | | | | | | R827 | C-3 | | | | |
| | | | | | | | | R828 | B-3 | | | | |
| | | | | | | | | R829 | B-3 | | | | |
| | | | | | | | | R830 | B-3 | | | | |
| | | | | | | | | R832 | B-3 | | | | |
| | | | | | | | | R833 | B-3 | | | | |
| | | | | | | | | R834 | A-3 | | | | |
| | | | | | | | | R835 | B-3 | | | | |
| | | | | | | | | R836 | B-3 | | | | |
| | | | | | | | | R837 | C-3 | | | | |
| | | | | | | | | R840 | C-1 | | | | |
| | | | | | | | | R842 | C-1 | | | | |
| | | | | | | | | R847 | C-3 | | | | |
| | | | | | | | | R848 | C-2 | | | | |
| | | | | | | | | R849 | C-2 | | | | |
| | | | | | | | | R851 | C-2 | | | | |
| | | | | | | | | R853 | C-2 | | | | |

SECTION 5 ADJUSTMENTS

Before starting adjustment

EVR Data Re-writing Procedure When Replacing Board

The data that is stored in the repair board, is not necessarily correct.
Perform either procedure 1 or procedure 2 or procedure 3 when replacing board.

Procedure 1

Save the EVR data of the machine in which a board is going to be replaced. Download the saved data after a board is replaced.

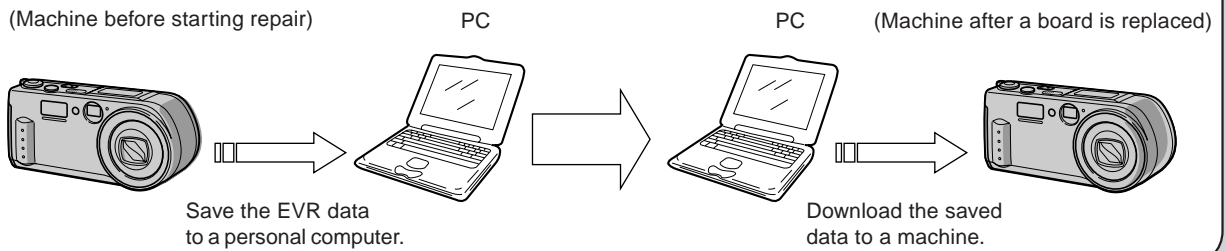

Procedure 2

Remove the EEPROM from the board of the machine that is going to be repaired. Install the removed EEPROM to the replaced board.

Remove the EEPROM and install it.

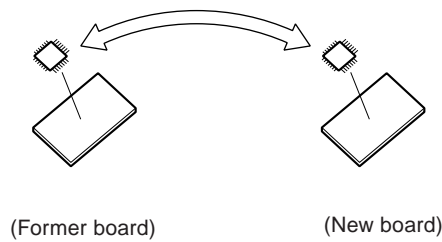

Procedure 3

When the data cannot be saved due to defective EEPROM, or when the EEPROM cannot be removed or installed, save the data from the same model of the same destination, and download it.

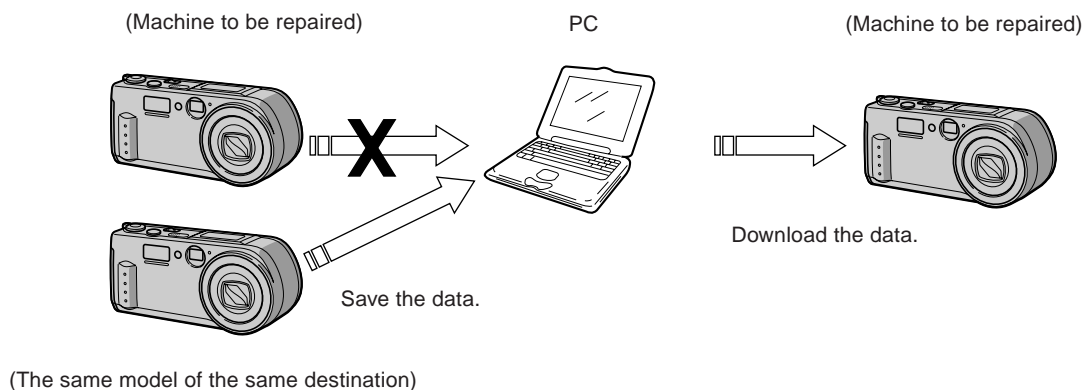

After the EVR data is saved and downloaded, check the respective items of the EVR data.
(Refer to page 5-2 for the items to be checked.)

1-1. Adjusting items when replacing main parts and boards

When replacing main parts and boards, adjust the items indicated by ● in the following table.

| Adjustment section | Adjustment | Replaced parts | | | | | | | | | | | | | | | | | | | | | |
|--|---|-------------------|------------|---------------------------|-----------|--------------|-------------|-------------|-------------|-------------------|--------------|--------------|--------------|-------------|-------------|-------------|--------------|--------------|-------------|--------------|-------------|--|---|
| | | Block replacement | | Mounted parts replacement | | | | | | Board replacement | | | | | | | | | | | | | |
| | | Lens device | Flash unit | LCD block | LCD block | CD-290 board | CA-66 board | HI-74 board | HI-74 board | PD-137 board | PD-137 board | PD-137 board | CD-290 board | CA-66 board | HI-74 board | MT-60 board | PD-137 board | PS-440 board | ST-62 board | PS-440 board | HI-74 board | | |
| Initialization of 7, B, D, E, F, page data | Initialization of D page data | | | | | | | | | | | | | | ● | | | | | | | | ● |
| | Initialization of 7, B, E, F page data | | | | | | | | | | | | | | | | | | | | | | |
| Video | Video sync level adj. | | | | | | | ● | ● | | | | | | ● | ● | | | | | | | |
| Camera | Flange back adj. | ● | | | | ● | | | | | | | | | | ● | | | | | | | |
| | F No. standard data input | ● | | | | ● | | | | | | ● | | | | ● | | | | | | | |
| | Mechanical shutter adjustment | ● | | | | ● | | | | | | ● | | | | ● | | | | | | | |
| | Light level adj. | ● | | | | ● | ● | | | | | ● | ● | | | ● | | | | | | | |
| | Auto white balance standard data input | ● | | | | ● | ● | | | | | ● | ● | | | ● | | | | | | | |
| | Auto white balance adj. | | | | | ● | ● | | | | | ● | ● | | | ● | | | | | | | |
| | Smear compensation adj. | | | | | ● | ● | | | | | ● | ● | | | ● | | | | | | | |
| | Color reproduction adj. | | | | | ● | ● | | | | | ● | ● | | | ● | | | | | | | |
| | Strobe white balance adj. | | ● | | | ● | ● | ● | | | | ● | ● | | | ● | | | ● | | | | |
| | CCD (black and white) defect compensation | | | | | ● | | | | | | ● | | | ● | | | | | | | | |
| LCD | LCD initial data input | | | | | | | | | | | | | | ● | ● | | | | | | | ● |
| | VCO adj. | | | | | | | | | | | | | | ● | ● | | | | | | | ● |
| | Black limit adj. | | | | | | | | | | | | | | ● | ● | | | | | | | ● |
| | Bright adj. | | | | | | | | | | | | | | ● | ● | | | | | | | ● |
| | Contrast adj. | | | | | | | | | | | | | | ● | ● | | | | | | | ● |
| | Color adj. | | | | | | | | | | | | | | ● | ● | | | | | | | ● |
| | VG center adj. | | | | | | | | | | | | | | ● | ● | | | | | | | ● |
| | V-COM adj. | | | | ● | | | | | | | | | | ● | ● | | | | | | | ● |
| | White balance adj. | | | ● | ● | | | | | | | | | ● | ● | | | | | | | | ● |
| System control | Battery down adj. | | | | | | | | | | | | | | ● | ● | | | | | | | ● |

Table 5-1-1

5-1. CAMERA SECTION ADJUSTMENT

1-1. PREPARATIONS BEFORE ADJUSTMENT

1-1-1. List of Service Tools

- Oscilloscope
- Color monitor
- Vectorscope
- Regulated power supply
- Digital voltmeter

| Ref. No. | Name | Parts Code | Usage |
|----------|---|--------------|---|
| J-1 | Filter for color temperature correction (C14) | J-6080-058-A | Auto white balance adjustment/check White balance adjustment/check |
| J-2 | Pattern box PTB-450 | J-6082-200-A | |
| J-3 | Color bar chart for pattern box | J-6020-250-A | |
| J-4 | Adjustment remote commander (RM-95 upgraded). (Note 1) | J-6082-053-B | |
| J-5 | Siemens star chart | J-6080-875-A | For checking the flange back |
| J-6 | Clear chart for pattern box | J-6080-621-A | |
| J-7 | CPC-9 jig (Note 2) | J-6082-393-C | For connecting the adjustment remote commander For adjusting the LCD block |
| J-8 | Mini pattern box | J-6082-353-B | For adjusting the flange back |
| J-9 | Back ground paper | J-2501-130-A | For adjusting the strobe |

Note 1: If the micro processor IC in the adjustment remote commander is not the new micro processor (UPD7503G-C56-12), The pages cannot be switched. In this case, replace with the new micro processor (8-759-148-35).

Note 2: The old CPC-9 jig (Parts code: J-6082-393-B) cannot be used, because it cannot operate the adjustment remote commander.

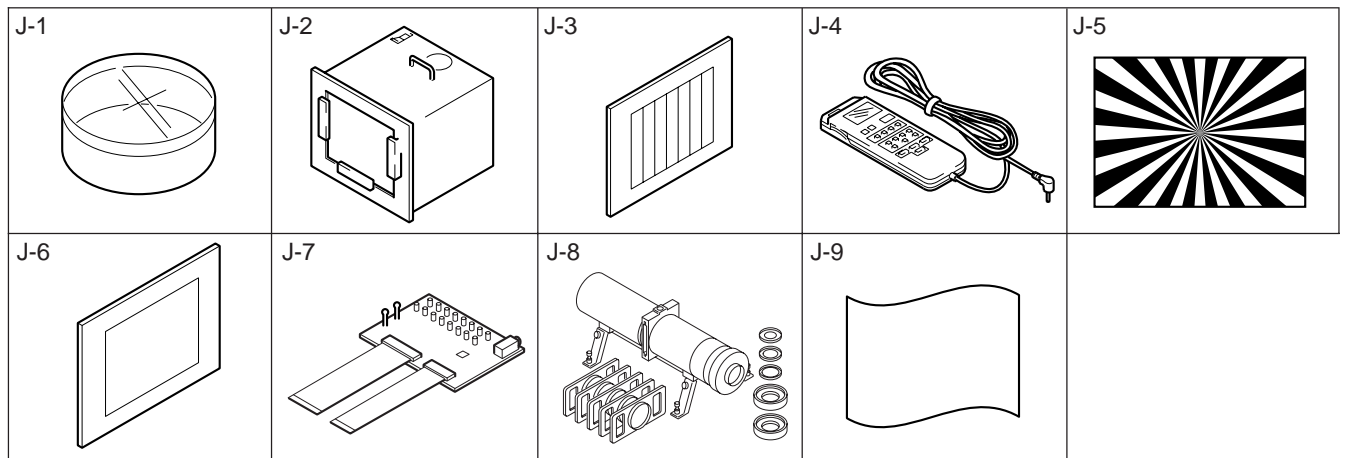

Fig. 5-1-1

1-1-2. Preparations

Note 1: For details of how remove the cabinet and boards, refer to "2. DISASSEMBLY".

Note 2: When performing only the adjustments, the lens block and boards need not be disassemble.

- 1) Connect the equipment for adjustments according to Fig. 5-1-5.
- 2) Connect the Adjusting remote commander to PD-137 board CN881 via CPC-9 jig (J-6082-393-C). (See Fig. 5-1-3)

Note 3: Setting the "Forced STILL mode power ON" Mode

- 1) Select page: 0, address: 01, and set data: 01.
- 2) Select page: D, address: 10, set data: 01, and press the PAUSE button of the adjusting remote commander.

The Above procedure will enable the camera power to be turned on. After completing adjustments, be sure to exit the "Forced STILL mode power ON Mode".

Note 4: Exiting the "Forced STILL mode power ON Mode"

- 1) Select page: 0, address: 01, and set data: 01.
- 2) Select page: D, address: 10, set data: 00, and press the PAUSE button of the adjusting remote commander.
- 3) Select page: 0, address: 01, and set data: 00.

1-1-3. Discharging of the Flashlight Power Supply

The capacitor which is used as power supply of flashlight is charged with 200 V to 300 V voltage. Discharge this voltage before starting adjustments in order to protect service engineers from electric shock during adjustment.

Discharge procedure

1. Press the FLASH button (SW-349 board S002) and turn off the FLASH LED (SW-349 board D002).
2. Fabricate the discharging jig as shown in Fig. 5-1-5 locally by yourself. Connect the discharging jig to the positive (+) and negative (-) terminal of the flash voltage charge capacitor. Allow ten seconds to discharge the voltage.

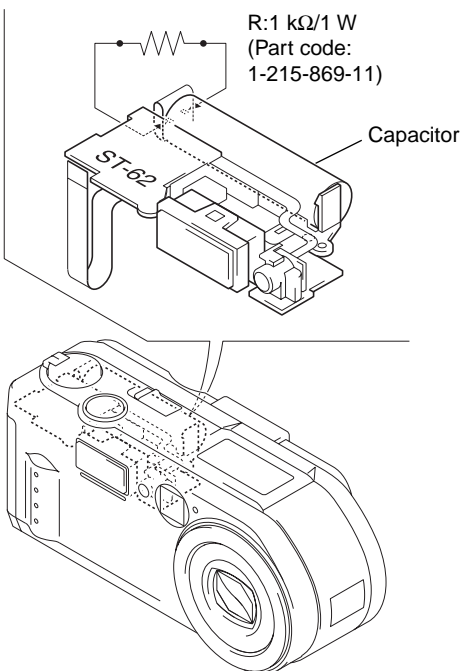

Fig. 5-1-4

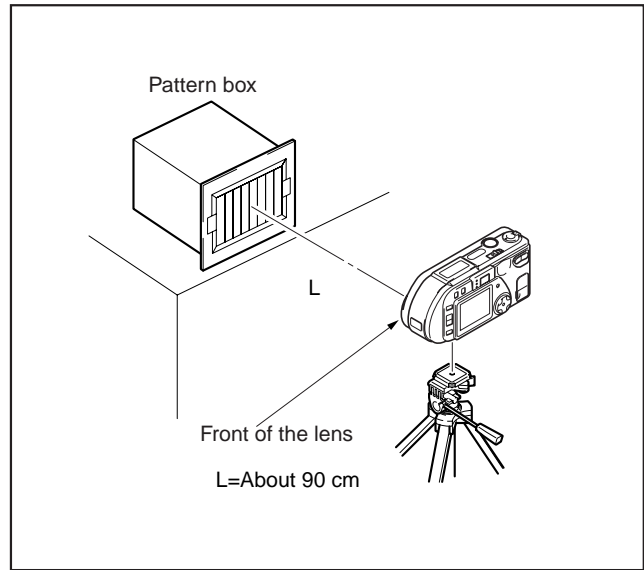
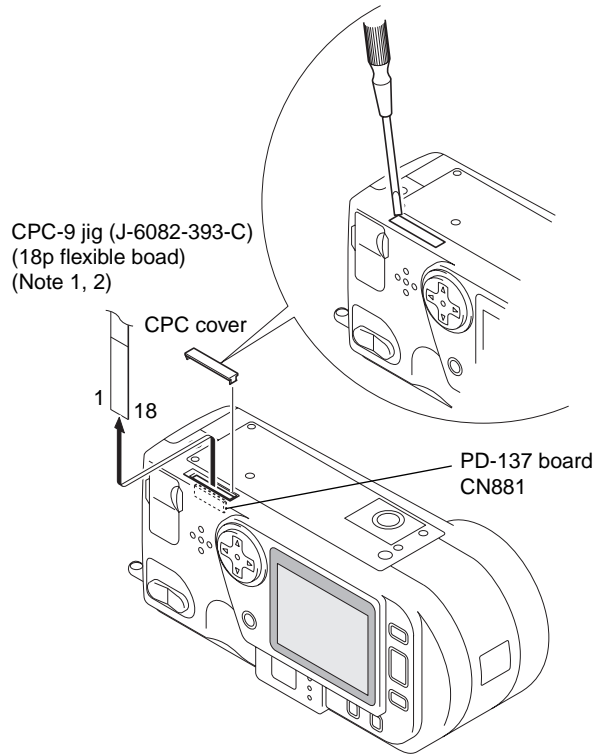

Fig. 5-1-2



Note 1: Don't use the 12 pin flexible board of CPC-9 jig. It causes damage to the unit.

Note 2: The old CPC-9 jig (Parts code: J-6082-393-B) cannot be used, because it cannot operate the adjustment remote commander.

Fig. 5-1-3

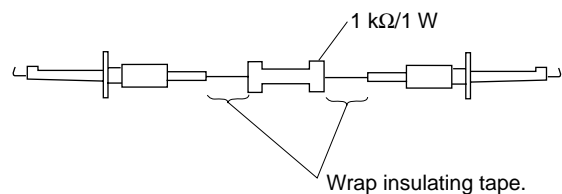

Fig. 5-1-5

Note 1: Don't use the 12 pin flexible board of CPC-9 jig.
It causes damage to the unit.

Note 2: The old CPC-9 jig (Parts code: J-6082-393-B)
cannot be used, because it cannot operate
the adjustment remote commander.

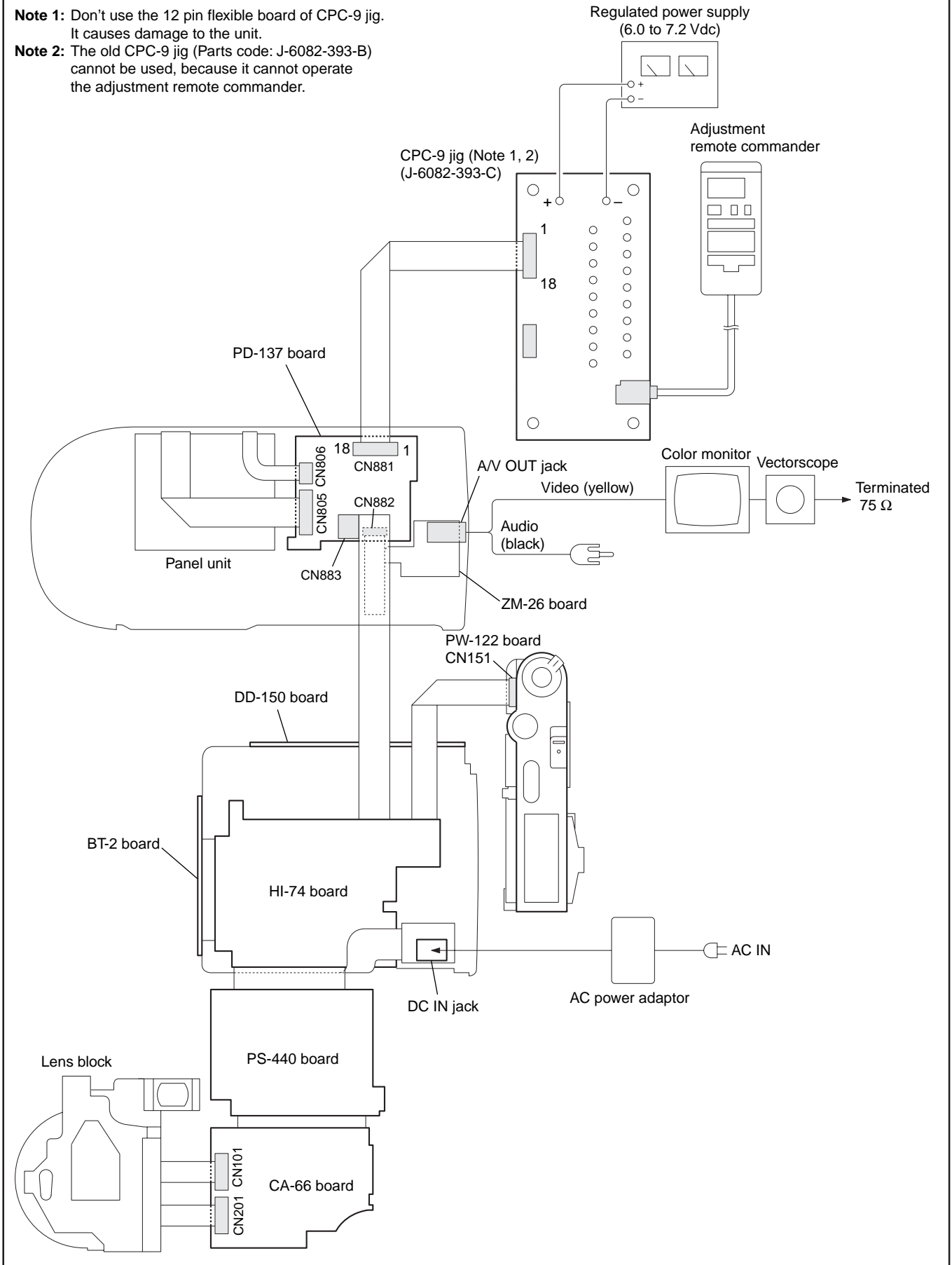

Fig. 5-1-6

1-1-4. Precautions

1. Setting the Switch

Unless otherwise specified, set the switches as follows and perform adjustments.

- | | | |
|---|---------------------------------------|--------|
| 1. PROGRAM AE button (SW-349 board S008) | 4. DEMO (Menu display) | OFF |
| AUTO (No mark indicated on LCD) | 5. VIDEO OUT (Menu display) | NTSC |
| 2. DISPLAY button (PD-137 board S881) | 6. WHITE BALANCE (Menu display) | AUTO |
| OSD OFF | 7. EXPOSURE | 0EV |
| 3. P. EFFECT (Menu display) | 8. FLASH LEVEL | NORMAL |
| OFF | | |

2. Order of Adjustments

Basically carry out adjustments in the order given.

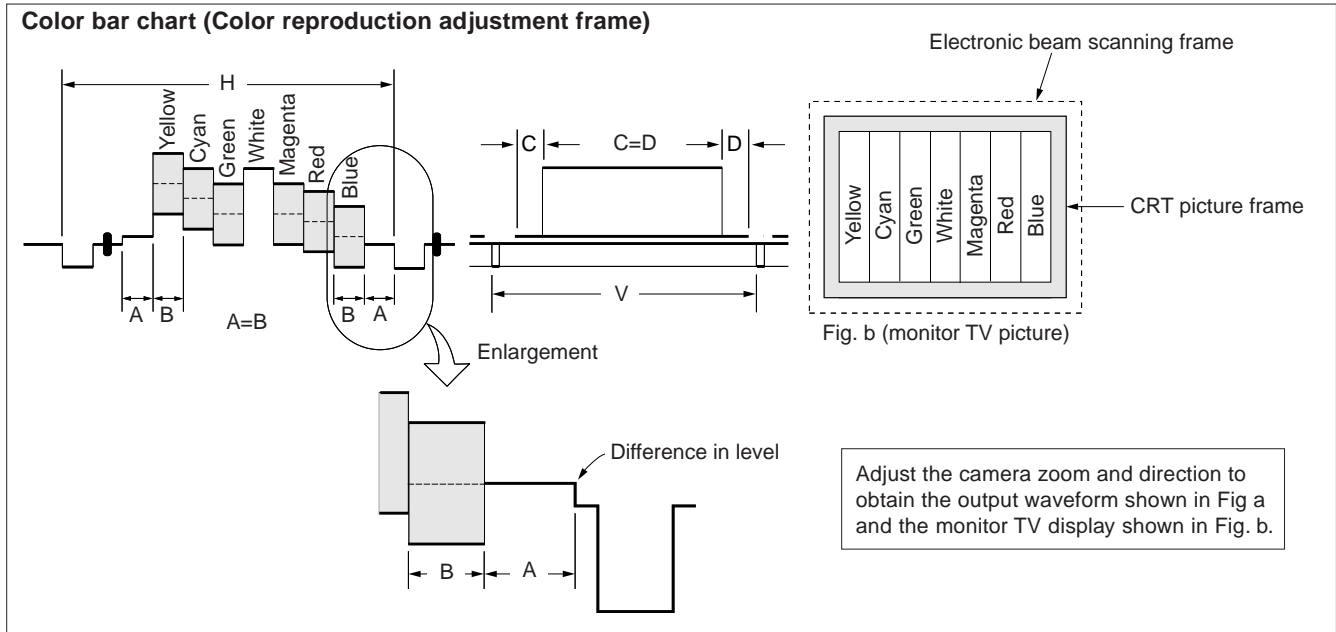

Fig. 5-1-7

3. Subjects

- 1) Color bar chart (Standard picture frame).
When performing adjustments using the color bar chart, adjust the picture frame as shown in Fig. 5-1-7. (Standard picture frame)
- 2) Clear chart (Standard picture frame)
Remove the color bar chart from the pattern box and insert a clear chart in its place. (Do not perform zoom operations during this time)
- 3) Chart for flange back adjustment
Join together a piece of white A0 size paper (1189mm × 841 mm) and a piece of black paper to make the chart shown in Fig. 5-1-8.

Note: Use a non-reflecting and non-glazing vellum paper. The size must be A0 or larger and the joint between the white and black paper must not have any undulations.

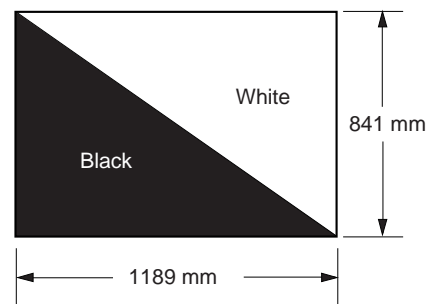

Fig. 5-1-8

4. Preparing the Flash Adjustment Box

A dark room is required to provide an accurate flash adjustment.
If it is not available, prepare the flash adjustment box as given below;

- 1) Provide woody board A, B and C of 15 mm thickness.

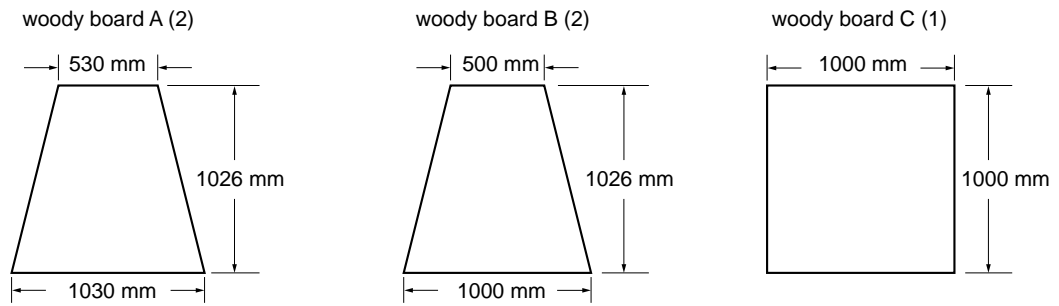

Fig. 5-1-9

- 2) Apply black mat paint to one side of woody board A and B.
- 3) Attach background paper (J-2501-130-A) to woody board C.
- 4) Assemble so that the black sides and the background paper side of woody board A, B and C are internal. (Fig 5-1-10)

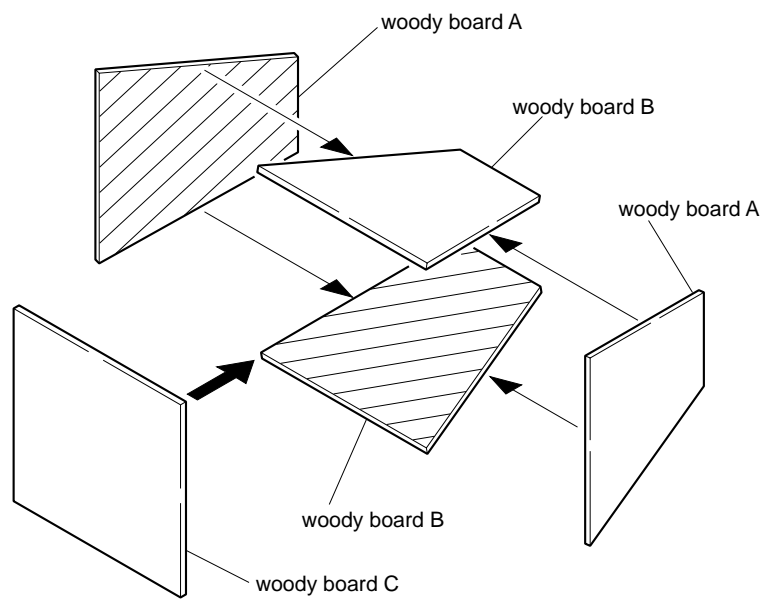

Fig. 5-1-10

1-2. INITIALIZATION OF B, D, E, F, 7 PAGE DATA

1-2-1. INITIALIZATION OF D PAGE DATA

1. Initializing D Page Data

Note: If the D page data has been initialized, the following adjustments need to be performed again.

- 1) Modification of D page data
- 2) LCD system adjustments
- 3) Battery end adjustments

| | |
|-------------------|----------|
| Adjusting page | D |
| Adjusting Address | 10 to EF |

Initializing Method:

| Order | Page | Address | Data | Procedure |
|-------|------|---------|------|--|
| 1 | 0 | 01 | 01 | |
| 2 | 2 | 03 | 00 | |
| 3 | 2 | 00 | 2D | |
| 4 | 2 | 01 | 2D | Press PAUSE button. |
| 5 | 2 | 02 | | Check the data changes to "01". |
| 6 | | | | Perform "Modification of D page Data". |

2. Modification of D Page Data

If the D page data has been initialized, change the data of the "Fixed data-2" address shown in the following table by manual input.

Modifying Method:

- 1) Before changing the data, select page: 0, address: 01, and set data: 01.
- 2) New data for changing are not shown in the tables because they are different in destination. When changing the data, copy the data built in the same model.

Note: If copy the data built in the different model, the camcorder may not operate.

- 3) When changing the data, press the PAUSE button of the adjustment remote commander each time when setting new data to write the data in the non-volatile memory.
- 4) Check that the data of adjustment addresses is the initial value. If not, change the data to the initial value.

Processing after Completing Modification of D Page Data:

| Order | Page | Address | Data | Procedure |
|-------|------|---------|------|---------------------|
| 1 | 6 | 00 | 29 | |
| 2 | 6 | 01 | 29 | Press PAUSE button. |

3. D Page Table

Note 1: Fixed data-1: Initialized data.

(Refer to "1. Initializing D Page Data")

Note 2: Fixed data-2: Modified data.

(Refer to "2. Modification of D Page Data")

| Address | Initial value | Remark |
|----------|---------------|---------------------------------|
| 00 to 0F | | |
| 10 | 00 | Test mode |
| 11 to 16 | | Fixed data-1 (Initialized data) |
| 17 | | Fixed data-2 |
| 18 to 5D | | Fixed data-1 (Initialized data) |
| 5E | | Fixed data-2 |
| 5F | | |
| 60,61 | | Fixed data-1 (Initialized data) |
| 62 | | Fixed data-2 |
| 63 | | |
| 64 to 8F | | Fixed data-1 (Initialized data) |
| 90 | 80 | Battery down adj. |
| 91 | 88 | |
| 92 | AD | |
| 93 | C2 | |
| 94 | CD | |
| 95 to 98 | | Fixed data-1 (Initialized data) |
| 99 | | Fixed data-2 |
| 9A | | |
| 9B | | |
| 9C | | |
| 9D | | |
| 9E | | |
| 9F | | |
| A0 | | |
| A1 | | |
| A2 to A7 | | Fixed data-1 (Initialized data) |
| A8 | | Fixed data-2 |
| A9 to AC | | Fixed data-1 (Initialized data) |
| AD | | Fixed data-2 |
| AE to CF | | Fixed data-1 (Initialized data) |
| D0 | 20 / 20 | Bright adj. (Note 3) |
| D1 | 62 / 58 | Color adj. (Note 3) |
| D2 | A0 / A0 | White balance adj. (Note 3) |
| D3 | 88 / 88 | |
| D4 | D0 / D0 | Contrast adj. (Note 3) |
| D5 | 90 / 90 | Black limit adj. (Note 3) |
| D6 | 90 / 90 | VG center adj.(Note 3) |
| D7 | 70 / 60 | VCO adj. (NTSC) (Note 3) |
| D8 | 98 / 90 | V-COM adj. (Note 3) |
| D9 | | Fixed data-1 (Initialized data) |
| DA | | Fixed data-2 |
| DB,DC | | Fixed data-1 (Initialized data) |
| DD | 90 / 80 | VCO adj. (PAL) (Note 3) |
| DE | | Fixed data-2 |
| DF to EF | | Fixed data-1 (Initialized data) |

Note 3: LCD TYPE SA / LCD TYPE ST

1-2-2. Initializing B, E, F, 7 Page Data

1. Initializing B, E, F, 7 Page Data

Note: If the B, E, F Page data has been initialized, “Modification of B, E, F, 7 Page Data” and following adjustments need to be performed again.

- 1) Modification of B, E, F, 7 page data
- 2) Video system adjustments
- 3) Camera system adjustments

| | |
|-------------------|----------|
| Adjusting page | F |
| Adjusting Address | 10 to FF |
| Adjusting page | E |
| Adjusting Address | 00 to FF |
| Adjusting page | B |
| Adjusting Address | 00 to FF |
| Adjusting page | 7 |
| Adjusting Address | 00 to FF |

Initializing Method:

| Order | Page | Address | Data | Procedure |
|-------|------|---------|------|---|
| 1 | 0 | 01 | 01 | |
| 2 | B | 00 | 00 | Press PAUSE button. |
| 3 | 6 | 03 | 09 | |
| 4 | 6 | 00 | 2D | |
| 5 | 6 | 01 | 2D | Press PAUSE button. |
| 6 | 6 | 02 | | Check the data changes to “01”. |
| 7 | | | | Perform “Modification of B, E, F, 7 page Data”. |

2. Modification of B, E, F, 7 Page Data

If the B, E, F, 7 Page data has been initialized, change the data of the “Fixed data-2” address shown in the following tables by manual input.

Modifying Method:

- 1) Before changing the data, select page: 0, address: 01, and set data: 01.
- 2) New data for changing are not shown in the tables because they are different in destination. When changing the data, copy the data built in the same model.
Note: If copy the data built in the different model, the camcorder may not operate.
- 3) When changing the data, press the PAUSE button of the adjustment remote commander each time when setting new data to write the data in the non-volatile memory.
- 4) Check that the data of adjustment addresses is the initial value. If not, change the data to the initial value.

Processing after Completing Modification of B, E, F, 7 Page data

| Order | Page | Address | Data | Procedure |
|-------|------|---------|------|---------------------|
| 1 | 6 | 00 | 29 | |
| 2 | 6 | 01 | 29 | Press PAUSE button. |

3. B Page Table

Note 1: Fixed data-1: Initialized data.

(Refer to “1. Initializing B, E, F, 7 Page Data”)

Note 2: Fixed data-2: Modified data.

(Refer to “2. Modification of B, E, F, 7 Page Data”)

| Address | Initial value | Remark |
|----------|---------------|---------------------------------|
| 00 | | Fixed data-2 |
| 01 to FF | | Fixed data-1 (Initialized data) |

4. E Page Table

Note 1: Fixed data-1: Initialized data.

(Refer to “1. Initializing B, E, F, 7 Page Data”)

Note 2: Fixed data-2: Modified data.

(Refer to “2. Modification of B, E, F, 7 Page Data”)

| Address | Initial value | Remark |
|----------|---------------|---------------------------------|
| 00 to FF | | Fixed data-1 (Initialized data) |

5. F Page Table

Note 1: Fixed data-1: Initialized data. (Refer to “1. Initializing B, E, F, 7 Page Data”)

Note 2: Fixed data-2: Modified data. (Refer to “2. Modification of B, E, F, 7 Page Data”)

| Address | Initial value | Remark |
|----------|---------------|--|
| 00 to 0F | | |
| 10 to 13 | | Fixed data-1 (Initialized data) |
| 14 | 00 | Flange back adj. |
| 15 | 00 | |
| 16 | 50 | |
| 17 | 00 | |
| 18 | 11 | |
| 19 | B1 | |
| 1A | 09 | |
| 1B | 0F | |
| 1C | 00 | |
| 1D | 00 | |
| 1E | 00 | |
| 1F | 00 | |
| 20 | 20 | |
| 21 | 20 | |
| 22 | 35 | |
| 23 | 40 | |
| 24 | 0A | |
| 25 | 00 | |
| 26 | 85 | Light level adj. |
| 27 | | Fixed data-1 (Initialized data) |
| 28 | 94 | Light level adj. |
| 29 | 00 | F No. standard data input |
| 2A | 00 | |
| 2B | 00 | |
| 2C | 00 | |
| 2D to 39 | | Fixed data-1 (Initialized data) |
| 3A | 2F | Auto white balance standard data input |
| 3B | 37 | |
| 3C | 40 | |
| 3D | D0 | |
| 3E | | Fixed data-1 (Initialized data) |
| 3F | B5 | Auto white balance adj. |
| 40 | 43 | Color reproduction adj. |
| 41 | 03 | |
| 42 | E9 | |
| 43 | 63 | |
| 44 | 83 | |
| 45 | D5 | |
| 46 | FE | |
| 47 | 73 | |
| 48 | 45 | |
| 49 to 4C | | Fixed data-1 (Initialized data) |
| 4D | 28 | Strobe white balance adj. |
| 4E | 6E | |
| 4F to 58 | | Fixed data-1 (Initialized data) |
| 59 | 00 | Auto white balance standard data input |
| 5A | 14 | Mechanical shutter adj. |
| 5B | | Fixed data-1 (Initialized data) |
| 5C | 63 | Color reproduction adj. |
| 5D | 83 | |
| 5E | 03 | |
| 5F | E9 | |
| 60 to 63 | | Fixed data-1 (Initialized data) |
| 64 | 10 | Strobe white balance adj. |
| 65 to 68 | | Fixed data-1 (Initialized data) |
| 69 | 02 | Strobe white balance adj. |
| 6A | 79 | |
| 6B | F8 | |

| Address | Initial value | Remark |
|----------|---------------|---------------------------------|
| 6C | 0B | Mechanical shutter adj. |
| 6D | A6 | |
| 6E | 20 | |
| 6F | 00 | |
| 70 | 20 | |
| 71 | 00 | |
| 72 | 20 | |
| 73 | 00 | |
| 74 | 20 | |
| 75 | 00 | |
| 76 | 0A | |
| 77 | AE | |
| 78 | 0A | |
| 79 | 00 | |
| 7A | 0A | |
| 7B | 00 | |
| 7C | 0A | |
| 7D | 00 | |
| 7E | 0A | |
| 7F | 00 | |
| 80 | 00 | Auto white balance adj. |
| 81 | 5A | Video sync level adj. |
| 82 to 86 | | Fixed data-1 (Initialized data) |
| 87 | FF | Flange back adj. |
| 88 | 00 | |
| 89 | 00 | |
| 8A | 00 | |
| 8B | 00 | |
| 8C | 00 | |
| 8D | 00 | |
| 8E | 00 | |
| 8F | 00 | |
| 90 | 00 | |
| 91 | 00 | |
| 92 | 00 | |
| 93 | 00 | |
| 94 | 00 | |
| 95 | 00 | |
| 96 | 00 | |
| 97 | 00 | |
| 98 | 00 | |
| 99 | 40 | |
| 9A | 00 | |
| 9B | 40 | |
| 9C | 80 | Mechanical shutter adj. |
| 9D | 00 | Smear compensation adj. |
| 9E | 00 | |
| 9F to A6 | | Fixed data-1 (Initialized data) |
| A7 | 80 | Mechanical shutter adj. |
| A8 | 80 | |
| A9 | 00 | Auto white balance adj. |
| AA | 00 | |
| AB to AD | | Fixed data-1 (Initialized data) |
| AE | 80 | Mechanical shutter adj. |
| AF | 80 | |
| B0 to D2 | | Fixed data-1 (Initialized data) |
| D3 | 00 | Mechanical shutter adj. |
| D4 | 00 | |
| D5 to FF | | Fixed data-1 (Initialized data) |

6. 7 Page Table

Note 1: Fixed data-1: Initialized data. (Refer to “1. Initializing B, E, F, 7 Page Data”)

Note 2: Fixed data-2: Modified data. (Refer to “2. Modification of B, E, F, 7 Page Data”)

| Address | Initial value | Remark |
|----------|---------------|---------------------------------|
| 00 to 5F | | Fixed data-1 (Initialized data) |
| 60 | 0F | CCD black defect compensation |
| 61 | FF | |
| 62 | 0F | |
| 63 | FF | |
| 64 | 0F | |
| 65 | FF | |
| 66 | 0F | |
| 67 | FF | |
| 68 | 0F | |
| 69 | FF | |
| 6A | 0F | |
| 6B | FF | |
| 6C | 0F | |
| 6D | FF | |
| 6E | 0F | |
| 6F | FF | |
| 70 | 0F | |
| 71 | FF | |
| 72 | 0F | |
| 73 | FF | |
| 74 | 0F | |
| 75 | FF | |
| 76 | 0F | |
| 77 | FF | |
| 78 | 0F | |
| 79 | FF | |
| 7A | 0F | |
| 7B | FF | |
| 7C | 0F | |
| 7D | FF | |
| 7E | 0F | |
| 7F | FF | |
| 80 | 0F | CCD white defect compensation |
| 81 | FF | |
| 82 | 0F | |
| 83 | FF | |
| 84 | 0F | |
| 85 | FF | |
| 86 | 0F | |
| 87 | FF | |
| 88 | 0F | |
| 89 | FF | |
| 8A | 0F | |
| 8B | FF | |
| 8C | 0F | |
| 8D | FF | |
| 8E | 0F | |
| 8F | FF | |
| 90 | 0F | |
| 91 | FF | |
| 92 | 0F | |

| Address | Initial value | Remark |
|----------|---------------|---------------------------------|
| 93 | FF | CCD white defect compensation |
| 94 | 0F | |
| 95 | FF | |
| 96 | 0F | |
| 97 | FF | |
| 98 | 0F | |
| 99 | FF | |
| 9A | 0F | |
| 9B | FF | |
| 9C | 0F | |
| 9D | FF | |
| 9E | 0F | |
| 9F | FF | |
| A0 | 0F | |
| A1 | FF | |
| A2 | 0F | |
| A3 | FF | |
| A4 to FF | | Fixed data-1 (Initialized data) |

1-3. VIDEO SYSTEM ADJUSTMENTS

1. Video Sync Level Adjustment

Adjust the sync level of the composite video signal output.

| | |
|----------------------|---|
| Mode | PLAY |
| Signal | Color bar (Test signal) |
| Measurement Point | Video terminal of A/V OUT jack (75 Ω terminated) |
| Measuring Instrument | Oscilloscope |
| Adjustment Page | F |
| Adjustment Address | 81 |
| Specified Value | A = 286 ± 5 mVp-p (NTSC) A = 300 ± 5 mVp-p (PAL) |

Menu setting:

- VIDEO OUT of SET UP menu
..... NTSC (NTSC mode)
..... PAL (PAL mode)

Adjusting method:

| Order | Page | Address | Data | Procedure |
|-------|------|---------|------|--|
| 1 | 0 | 01 | 01 | |
| 2 | 5 | F1 | 04 | |
| 3 | F | 81 | | Change the data and set the sync level (A) to the specified value. |
| 4 | | | | Press PAUSE button |

Processing after Completing Adjustments:

| Order | Page | Address | Data | Procedure |
|-------|------|---------|------|-----------|
| 1 | 5 | F1 | 00 | |
| 2 | 0 | 01 | 00 | |

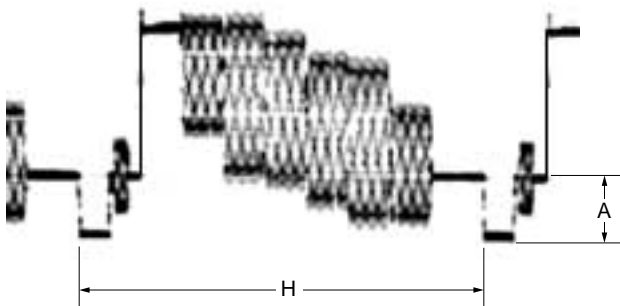

Fig. 5-1-11

2. Video Burst Level Check

Check the burst level of the composite video signal output.

| | |
|----------------------|---|
| Mode | PLAY |
| Signal | Color bar (Test signal) |
| Measurement Point | Video terminal of A/V OUT jack (75 Ω terminated) |
| Measuring Instrument | Oscilloscope |
| Specified Value | A = 286 ± 50 mVp-p (NTSC) A = 300 ± 50 mVp-p (PAL) |

Menu setting:

- VIDEO OUT of SET UP menu
..... NTSC (NTSC mode)
..... PAL (PAL mode)

Checking method:

| Order | Page | Address | Data | Procedure |
|-------|------|---------|------|---|
| 1 | 0 | 01 | 01 | |
| 2 | 5 | F1 | 04 | |
| 3 | | | | Check the burst level (A) to the specified value. |

Processing after Completing Adjustments:

| Order | Page | Address | Data | Procedure |
|-------|------|---------|------|-----------|
| 1 | 5 | F1 | 00 | |
| 2 | 0 | 01 | 00 | |

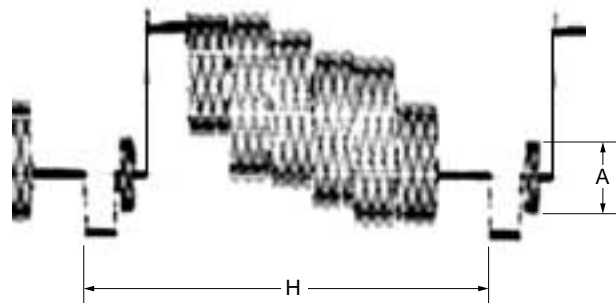

Fig. 5-1-12

1-4. CAMERA SYSTEM ADJUSTMENT

Before perform the camera system adjustments, check that the specified values of “VIDEO SYSTEM ADJUSTMENTS” are satisfied.

Data setting during camera system adjustment

Perform the following data setting before the camera system adjustments.

Data setting method:

| Order | Page | Address | Data | Procedure |
|-------|------|---------|------|---------------------|
| 1 | 0 | 01 | 01 | |
| 2 | E | 43 | 10 | Press PAUSE button. |
| 3 | E | 8F | 00 | Press PAUSE button. |
| 4 | B | 67 | 00 | Press PAUSE button. |

After completing the camera system adjustments, release the data setting:

| Order | Page | Address | Data | Procedure |
|-------|------|---------|------|---------------------|
| 1 | 0 | 01 | 01 | |
| 2 | E | 43 | 0F | Press PAUSE button. |
| 3 | E | 8F | 11 | Press PAUSE button. |
| 4 | B | 67 | 85 | Press PAUSE button. |
| 5 | 0 | 01 | 00 | |

1. Flange Back Adjustment (Using the minipattern box)

The inner focus lens flange back adjustment is carried out automatically. In whichever case, the focus will be deviated during auto focusing/manual focusing.

| | |
|----------------------|--|
| Mode | STILL |
| Subject | Siemens star chart with ND filter for minipattern box (Note 1) |
| Measurement Point | Check operation on TV monitor |
| Measuring Instrument | |
| Adjustment Page | F |
| Adjustment Address | "14 to 25, 87 to 9B" |

Note 1: Dark Siemens star chart.

Note 2: Check that the data of page: 6, address: 02 is "00".
If not, turn the power of unit OFF/ON.

Menu Setting:

VIDEO OUT of SETUP menu NTSC (NTSC mode)
(This adjustment must be performed in NTSC mode, so don't set the menu setting to "PAL")

Preparations before adjustments:

1) The minipattern box is installed as shown in the following figure.

Note 3: The attachment lenses are not used.

Note 4: Take care not to hit the mini-pattern box when extending the lens.

- 2) Install the minipattern box so that the distance between it and the front of lens of camera is less than 3 cm.
- 3) Make the height of minipattern box and the camera equal.
- 4) Check the output voltage of the regulated power supply is the specified voltage ± 0.01 Vdc.
- 5) Check that the center of Siemens star chart meets the center of shot image screen with the zoom lens at TELE end and WIDE end respectively.
- 6) Check that the data on page: F, address: 14 to 25, 87 to 9B are initial value (See table below).

| Address | Data | Address | Data | Address | Data |
|---------|------|---------|------|---------|------|
| 14 | 00 | 21 | 20 | 8F | 00 |
| 15 | 00 | 22 | 35 | 90 | 00 |
| 16 | 50 | 23 | 40 | 91 | 00 |
| 17 | 00 | 24 | 0A | 92 | 00 |
| 18 | 11 | 25 | 00 | 93 | 00 |
| 19 | B1 | 87 | FF | 94 | 00 |
| 1A | 09 | 88 | 00 | 95 | 00 |
| 1B | 0F | 89 | 00 | 96 | 00 |
| 1C | 00 | 8A | 00 | 97 | 00 |
| 1D | 00 | 8B | 00 | 98 | 00 |
| 1E | 00 | 8C | 00 | 99 | 40 |
| 1F | 00 | 8D | 00 | 9A | 00 |
| 20 | 20 | 8E | 00 | 9B | 40 |

Specified voltage: The specified voltage varies according to the minipatternbox, so adjustment the power supply output voltage to the specified voltage written on the sheet which is supplied with the minipattern box.

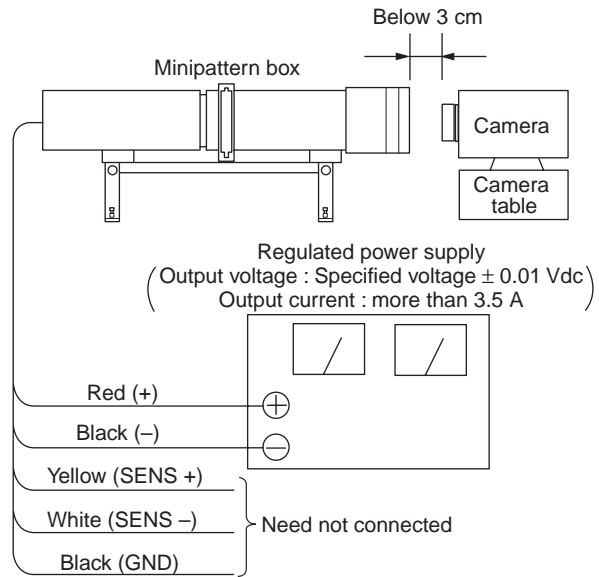

Fig. 5-1-13

Adjusting method:

| Order | Page | Address | Data | Procedure |
|-------|------|---------|------|--|
| 1 | 0 | 01 | 01 | |
| 2 | 5 | F1 | FF | |
| 3 | D | 63 | 40 | Press PAUSE button. |
| 4 | | | | Perform "Data setting during camera system adjustment". (Refer to page 5-13) |
| 5 | 6 | 01 | 13 | Press PAUSE button. |
| 6 | 6 | 01 | 27 | Press PAUSE button. (Note 5) |
| 7 | 6 | 02 | | Check the data changes to "01". |
| 8 | F | 87 | | Check the data. 00: Normal 01 to FF: Defective |

Note 5: The adjustment data will be automatically input to page: F, address: 14 to 25 and 87 to 9B.

Processing after Completing Adjustment:

| Order | Page | Address | Data | Procedure |
|-------|------|---------|------|--|
| 1 | 6 | 01 | 00 | Press PAUSE button. |
| 2 | 5 | F1 | 00 | |
| 3 | D | 63 | 00 | Press PAUSE button. |
| 4 | | | | Release the data setting performed at step 4. (Refer to page 5-13) |
| 5 | 0 | 01 | 00 | |
| 6 | | | | Perform "Flange Back Check". |

**2. Flange Back Adjustment
(Using the flange back adjustment chart)**

The inner focus lens flange back adjustment is carried out automatically. In whichever case, the focus will be deviated during auto focusing/manual focusing.

| | |
|----------------------|---|
| Mode | STILL |
| Subject | Flange back adjustment chart (2.0 m from the front of lens) (Luminance: 300 to 400 lux) |
| Measurement Point | Check operation on TV monitor |
| Measuring Instrument | |
| Adjustment Page | F |
| Adjustment Address | 14 to 25, 87 to 9B |

Note 1: Check that the data of page: 6, address: 02 is “00”.
If not, turn the power of unit OFF/ON.

Menu Setting:

VIDEO OUT of SETUP menu NTSC (NTSC mode)
(This adjustment must be performed in NTSC mode, so don't set the menu setting to “PAL”)

Preparations before adjustments:

- 1) Place the Flange back adjustment chart 2.0 m from the front of the lens.
- 2) Check that the center of Flange back adjustment chart meets the center of shot image screen with the zoom lens at TELE end and WIDE end respectively.
- 3) Check that the data on page: F, address: 14 to 25, 87 to 9B are initial value (See table below).

| Address | Data | Address | Data | Address | Data |
|---------|------|---------|------|---------|------|
| 14 | 00 | 21 | 20 | 8F | 00 |
| 15 | 00 | 22 | 35 | 90 | 00 |
| 16 | 50 | 23 | 40 | 91 | 00 |
| 17 | 00 | 24 | 0A | 92 | 00 |
| 18 | 11 | 25 | 00 | 93 | 00 |
| 19 | B1 | 87 | FF | 94 | 00 |
| 1A | 09 | 88 | 00 | 95 | 00 |
| 1B | 0F | 89 | 00 | 96 | 00 |
| 1C | 00 | 8A | 00 | 97 | 00 |
| 1D | 00 | 8B | 00 | 98 | 00 |
| 1E | 00 | 8C | 00 | 99 | 40 |
| 1F | 00 | 8D | 00 | 9A | 00 |
| 20 | 20 | 8E | 00 | 9B | 40 |

Adjusting method:

| Order | Page | Address | Data | Procedure |
|-------|------|---------|------|---|
| 1 | 0 | 01 | 01 | |
| 2 | 5 | F1 | FF | |
| 3 | D | 63 | 40 | Press PAUSE button. |
| 4 | | | | Perform “Data setting during camera system adjustment”. (Refer to page 5-13) |
| 5 | 6 | 01 | 13 | Press PAUSE button. |
| 6 | 6 | 01 | 15 | Press PAUSE button. (Note 2) |
| 7 | 6 | 02 | | Check the data changes to “01”. |
| 8 | F | 87 | | Check the data. 00: Normal 01 to FF: Defective |

Note 2:The adjustment data will be automatically input to page: F, address: 14 to 25 and 87 to 9B.

Processing after Completing Adjustment:

| Order | Page | Address | Data | Procedure |
|-------|------|---------|------|--|
| 1 | 6 | 01 | 00 | Press PAUSE button. |
| 2 | 5 | F1 | 00 | |
| 3 | D | 63 | 00 | Press PAUSE button. |
| 4 | | | | Release the data setting performed at step 4. (Refer to page 5-13) |
| 5 | 0 | 01 | 00 | |
| 6 | | | | Perform “Flange Back Check”. |

3. Flange Back Check

| | |
|----------------------|--|
| Mode | STILL |
| Subject | Siemens star (2.0 m from the front of the lens) (Luminance: approx. 200 lux) |
| Measurement Point | Check operation on TV monitor |
| Measuring Instrument | |
| Specified value | Focused at the TELE end and WIDE end |

Checking method:

| Order | Page | Address | Data | Procedure |
|-------|------|---------|------|--|
| 1 | | | | Place the Siemens star 2.0 m from the front of the lens. |
| 2 | | | | To open the IRIS , decrease the luminous intensity to the Siemens star up to a point before noise appear on the image. |
| 3 | 0 | 01 | 01 | |
| 4 | 5 | F1 | FF | |
| 5 | D | 63 | 40 | Press PAUSE button. |
| 6 | | | | Perform “Data setting during camera system adjustment”. (Refer to page 5-13) |
| 7 | | | | Shoot the Siemens star with the zoom TELE end. |
| 8 | | | | Turn on the auto focus. |
| 9 | | | | Check that the lens is focused. |
| 10 | 6 | 2C | 01 | |
| 11 | | | | While observe the TV monitor, change the zoom to the WIDE end and check that the lens is focused. |

Processing after Completing Adjustment:

| Order | Page | Address | Data | Procedure |
|-------|------|---------|------|---|
| 1 | 6 | 2C | 00 | |
| 2 | 5 | F1 | 00 | |
| 3 | D | 63 | 00 | Press PAUSE button. |
| 4 | | | | Release the data setting performed at step 6. (Refer to page 5-13) |
| 5 | 0 | 01 | 00 | |

4. F No. Standard Data Input

Compensate the unevenness of the iris meter sensitivity.

| | |
|--------------------|---|
| Mode | STILL |
| Subject | Clear chart (Color reproduction adjustment frame with the zoom lens at WIDE end) |
| Adjustment Page | F |
| Adjustment Address | 29 to 2C |

Note 1: Check that the data of page: 6, address: 02 is “00”.
If not, turn the power of unit OFF/ON.

Adjusting method:

| Order | Page | Address | Data | Procedure |
|-------|------|---------|------|---|
| 1 | | | | Shoot the Clear chart with the zoom WIDE end. |
| 2 | 0 | 01 | 01 | |
| 3 | 5 | F1 | FF | |
| 4 | D | 63 | 40 | Press PAUSE button. |
| 5 | | | | Perform “Data setting during camera system adjustment”. (Refer to page 5-13) |
| 6 | E | 51 | | Note down the data. |
| 7 | E | 51 | FF | Press PAUSE button. |
| 8 | 6 | 01 | BB | Press PAUSE button. (Note 2) |
| 9 | 6 | 02 | | Check the data changes to “01”. |

Note 2: The adjustment data will be automatically input to page: F, address: 29 to 2C.

Processing after Completing Adjustment:

| Order | Page | Address | Data | Procedure |
|-------|------|---------|------|---|
| 1 | 6 | 01 | 00 | Press PAUSE button. |
| 2 | E | 51 | | Set data noted down at step 6, and press PAUSE button. |
| 3 | 5 | F1 | 00 | |
| 4 | D | 63 | 00 | Press PAUSE button. |
| 5 | | | | Release the data setting performed at step 5. (Refer to page 5-13) |
| 6 | 0 | 01 | 00 | |

5. Mechanical Shutter Adjustment

Adjust the period which the mechanical shutter is closed, and compensate the exposure.

| | |
|--------------------|---|
| Mode | STILL |
| Subject | Clear chart (10 cm from the front of the lens) |
| Adjustment Page | F |
| Adjustment Address | 5A, 6C to 7F, 9C, A7, A8, AE, AF, D3, D4 |

Note 1: Check that the data of page: 6, address: 02 is "00".
If not, turn the power of unit OFF/ON.

Adjusting method:

| Order | Page | Address | Data | Procedure |
|-------|------|---------|------|---|
| 1 | | | | Shoot the Clear chart with the zoom WIDE end. |
| 2 | 0 | 01 | 01 | |
| 3 | 5 | F1 | FF | |
| 4 | D | 63 | 40 | Press PAUSE button. |
| 5 | | | | Perform "Data setting during camera system adjustment". (Refer to page 5-13) |
| 6 | 6 | 01 | AD | Press PAUSE button (Note 2) |
| 7 | 6 | 02 | | Check the data changes to "01". |
| 8 | 6 | AB | | Check the data. 00 : Normal 01 to FF : Defective |

Note 2: The adjustment data will be automatically input to page: F, address: 5A, 6C to 7F, 9C, A7, A8, AE, AF, D3 and D4.

Processing after Completing Adjustment:

| Order | Page | Address | Data | Procedure |
|-------|------|---------|------|---|
| 1 | 6 | 01 | 00 | Press PAUSE button. |
| 2 | 5 | F1 | 00 | |
| 3 | D | 63 | 00 | Press PAUSE button. |
| 4 | | | | Release the data setting performed at step 5. (Refer to page 5-13) |
| 5 | 0 | 01 | 00 | |

6. Picture Frame Setting

| | |
|----------------------|--|
| Mode | STILL |
| Subject | Color bar chart (Color reproduction adjustment frame) |
| Measurement Point | Video terminal of A/V OUT jack (75 Ω terminated) |
| Measuring Instrument | Oscilloscope and TV monitor |
| Specified Value | A=B, C=D, E=F |

Note 1: Displayed data of the page 1 of adjusting remote commander.

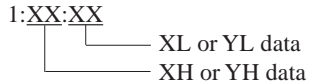

Setting method:

| Order | Page | Address | Data | Procedure |
|-------|------|---------|------|--|
| 1 | 0 | 01 | 01 | |
| 2 | 5 | F1 | FF | |
| 3 | D | 63 | 40 | Press PAUSE button. |
| 4 | | | | Perform "Data setting during camera system adjustment". (Refer to page 5-13) |
| 5 | | | | Adjust the zoom and the camera direction, and set to the picture frame to the specified position. |
| 6 | | | | Mark the position of the picture frame on the TV picture monitor, and adjust the picture frame to this position in following adjustment using "Color reproduction adjustment frame". |
| 7 | 0 | 03 | 18 | |
| 8 | 1 | | | Note down the XH and XL data. (Note 1) |
| 9 | 0 | 03 | 22 | |
| 10 | 1 | | | Note down the YH and YL data. (Note 1) |
| 11 | 0 | 03 | 00 | |
| 12 | 5 | F1 | 00 | |
| 13 | D | 63 | 00 | Press PAUSE button. |
| 14 | | | | Release the data setting performed at step 4. (Refer to page 5-13) |
| 15 | 0 | 01 | 00 | |

How to reset the zoom and focus when they deviated:

| Order | Page | Address | Data | Procedure |
|-------|------|---------|------|---------------------|
| 1 | 6 | 90 | XL | (Note 2) |
| 2 | 6 | 91 | XH | (Note 2) |
| 3 | 6 | 92 | YL | (Note 3) |
| 4 | 6 | 93 | YH | (Note 3) |
| 5 | 6 | 6C | 01 | |
| 6 | 6 | 01 | 79 | Press PAUSE button. |
| 7 | | | | Wait for 1 second. |
| 8 | 6 | 2C | 01 | |
| 9 | 6 | 01 | 00 | Press PAUSE button. |

Note 2: The data noted down at step 8 of "Setting method".

Note 3: The data noted down at step 10 of "Setting method".

Check on the oscilloscope

1. Horizontal period

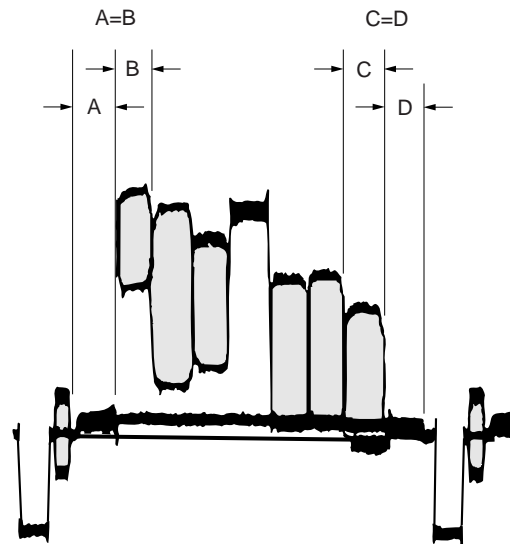

Fig. 5-1-14

2. Vertical period

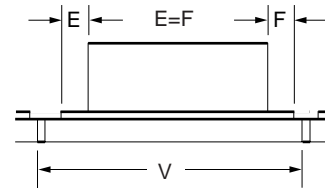

Fig. 5-1-15

Check on the TV monitor

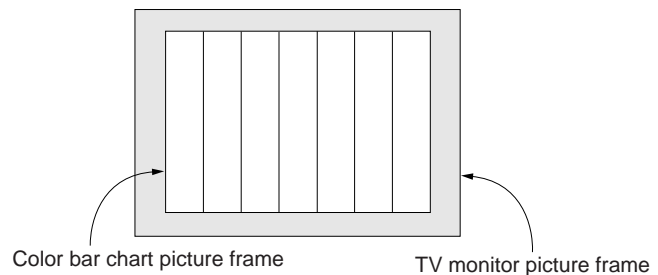

Fig. 5-1-16

7. Light Level Adjustment

Adjust the standard LV value.

| | |
|----------------------|---|
| Mode | STILL |
| Subject | Clear chart (Color reproduction adjustment frame with the zoom lens at WIDE end) |
| Measurement Point | Displayed data of page: 1 (Note 2) |
| Measuring Instrument | Adjusting remote commander |
| Adjustment Page | F |
| Adjustment Address | 26, 28 |
| Specified Value | AE level 1: 0FE0 to 1020 |

Note 1: Check that the data of page: 6, address: 02 is "00".

If not, turn the power of unit OFF/ON

Note 2: The right four digits of the page: 1 displayed data of the adjusting remote commander.

1:XX;XX

Displayed data

Adjusting method:

| Order | Page | Address | Data | Procedure |
|-------|------|---------|------|--|
| 1 | 0 | 01 | 01 | |
| 2 | 5 | F1 | FF | |
| 3 | D | 63 | 40 | Press PAUSE button. |
| 4 | | | | Perform "Data setting during camera system adjustment". (Refer to page 5-13) |
| 5 | 6 | 01 | 0D | Press PAUSE button. (Note 3) |
| 6 | 6 | 02 | | Check the data changes to "01". |
| 7 | 0 | 03 | 06 | |
| 8 | 1 | | | Check that the displayed data (Note 2) satisfies the AE level 1 specified value. |

Note 3: The adjustment data will be automatically input to page: F, address: 26 and 28.

Processing after Completing Adjustment:

| Order | Page | Address | Data | Procedure |
|-------|------|---------|------|--|
| 1 | 0 | 03 | 00 | |
| 2 | 6 | 01 | 00 | Press PAUSE button. |
| 3 | 5 | F1 | 00 | |
| 4 | D | 63 | 00 | Press PAUSE button. |
| 5 | | | | Release the data setting performed at step 4. (Refer to page 5-13) |
| 6 | 0 | 01 | 00 | |

8. Auto White Balance Standard Data Input

Adjust the white balance standard data at 3200K.

| | |
|--------------------|--|
| Mode | STILL |
| Subject | Clear chart (Color reproduction adjustment frame) |
| Adjustment Page | F |
| Adjustment Address | 3A to 3D, 59 |

Note 1: Check that the data of page: 6, address: 02 is "00".

If not, turn the power of unit OFF/ON.

Note 2: Refer to "Picture Frame Setting" for XH, XL, YH and YL.

Adjusting method:

| Order | Page | Address | Data | Procedure |
|-------|------|---------|------|--|
| 1 | 0 | 01 | 01 | |
| 2 | 5 | F1 | FF | |
| 3 | D | 63 | 40 | Press PAUSE button. |
| 4 | | | | Perform "Data setting during camera system adjustment". (Refer to page 5-13) |
| 5 | 6 | 90 | 00 | |
| 6 | 6 | 91 | 04 | |
| 7 | 6 | 92 | 00 | |
| 8 | 6 | 93 | 30 | |
| 9 | 6 | 6C | 01 | |
| 10 | 6 | 2C | 01 | |
| 11 | 6 | 01 | 79 | Press PAUSE button. |
| 12 | | | | Wait for 3 seconds. |
| 13 | 6 | 01 | 11 | Press PAUSE button. |
| 14 | 6 | 01 | 0B | Press PAUSE button. (Note 3) |
| 15 | 6 | 02 | | Check the data changes to "01". |
| 16 | 6 | 90 | XL | (Note 2) |
| 17 | 6 | 91 | XH | (Note 2) |
| 18 | 6 | 92 | YL | (Note 2) |
| 19 | 6 | 93 | YH | (Note 2) |
| 20 | 6 | 6C | 01 | |
| 21 | 6 | 2C | 01 | |
| 22 | 6 | 01 | 79 | Press PAUSE button. |
| 23 | | | | Wait for 3 seconds |

Note 3: The adjustment data will be automatically input to page: F, address: 3A to 3D and 59.

Processing after Completing Adjustment:

| Order | Page | Address | Data | Procedure |
|-------|------|---------|------|--|
| 1 | 6 | 01 | 00 | Press PAUSE button. |
| 2 | 6 | 6C | 00 | |
| 3 | 6 | 2C | 00 | |
| 4 | 5 | F1 | 00 | |
| 5 | D | 63 | 00 | Press PAUSE button. |
| 6 | | | | Release the data setting performed at step 4. (Refer to page 5-13) |
| 7 | 0 | 01 | 00 | |
| 8 | | | | Perform "Auto White Balance Adjustment". |

9. Auto White Balance Adjustment

Adjust to the proper auto white balance output data.

If it is not correct, auto white balance and color reproducibility will be poor.

| | |
|----------------------|--|
| Mode | STILL |
| Subject | Clear chart (Color reproduction adjustment frame) |
| Filter | Filter C14 for color temperature correction |
| Measurement Point | Displayed data of page: 1 (Note 3) |
| Measuring Instrument | Adjusting remote commander |
| Adjustment Page | F |
| Adjustment Address | 3F, 40, 80, A9, AA |
| Specified Value | R ratio: 28E0 to 2A20 B ratio: 5C60 to 5DA0 |

Note 1: Perform “Auto White Balance Reference Data Input” before this adjustment.

Note 2: Check that the data of page: 6, address: 02 is “00”.
If not, turn the power of unit OFF/ON.

Note 3: The right four digits of the page: 1 displayed data of the adjusting remote commander.

1:XX:XX

————— Displayed data

Note 4: Refer to “Picture Frame Setting” for XH, XL, YH and YL.

Adjusting method:

| Order | Page | Address | Data | Procedure |
|-------|------|----------------------|----------------------|--|
| 1 | | | | Place the C14 filter on the lens. |
| 2 | 0 | 01 | 01 | |
| 3 | 5 | F1 | FF | |
| 4 | D | 63 | 40 | Press PAUSE button. |
| 5 | | | | Perform “Data setting during camera system adjustment”. (Refer to page 5-13) |
| 6 | F | 27 | | Note down the data. |
| 7 | F | 27 | 80 | Press PAUSE button. |
| 8 | 6 | 90 | 00 | |
| 9 | 6 | 91 | 04 | |
| 10 | 6 | 92 | 00 | |
| 11 | 6 | 93 | 30 | |
| 12 | 6 | 6C | 01 | |
| 13 | 6 | 2C | 01 | |
| 14 | 6 | 01 | 79 | Press PAUSE button. |
| 15 | | | | Wait for 3 seconds. |
| 16 | 6 | 01 | A7 | Press PAUSE button. |
| 17 | F | 49 4A 4B 4C | | Note down the data. |
| 18 | F | 49 4A 4B 4C | 29 80 5D 00 | Press PAUSE button. |

| | | | | |
|----|---|----|----|---|
| 19 | 6 | 01 | A5 | Press PAUSE button. (Note 5) |
| 20 | 6 | 02 | | Check the data changes to “01”. |
| 21 | 6 | 01 | 3F | Press PAUSE button. |
| 22 | 0 | 03 | 04 | |
| 23 | 1 | | | Check that the displayed data (Note 3) satisfied the R ratio specified value. |
| 24 | 0 | 03 | 05 | |
| 25 | 1 | | | Check that the displayed data (Note 3) satisfied the B ratio specified value. |
| 26 | 6 | 90 | XL | (Note 4) |
| 27 | 6 | 91 | XH | (Note 4) |
| 28 | 6 | 92 | YL | (Note 4) |
| 29 | 6 | 93 | YH | (Note 4) |
| 30 | 6 | 6C | 01 | |
| 31 | 6 | 2C | 01 | |
| 32 | 6 | 01 | 79 | Press PAUSE button. |
| 33 | | | | Wait for 3 seconds |
| 34 | 6 | 01 | 11 | Press PAUSE button. |
| 35 | 6 | 13 | 88 | Press PAUSE button. |
| 36 | 6 | 01 | D3 | Press PAUSE button. (Note 5) |
| 37 | 6 | 02 | 01 | Check the data changes to “01”. |

Note 5: The adjustment data will be automatically input to page: F, address: 3F, 40, 80, A9 and AA.

Processing after Completing Adjustment:

| Order | Page | Address | Data | Procedure |
|-------|------|----------------------|------|--|
| 1 | 0 | 03 | 00 | |
| 2 | 6 | 01 | 00 | Press PAUSE button. |
| 3 | F | 27 | | Set data noted down at step 6, and press PAUSE button. |
| 4 | F | 49 4A 4B 4C | | Set data noted down at step 17, and press PAUSE button. |
| 5 | 6 | 13 | 00 | Press PAUSE button. |
| 6 | 5 | F1 | 00 | |
| 7 | D | 63 | 00 | Press PAUSE button. |
| 8 | | | | Release the data setting performed at step 5. (Refer to page 5-13) |
| 9 | 0 | 01 | 00 | |

10. Smear Compensation Adjustment

Adjust the smear compensation data from white balance standard data at 3200K.

| | |
|--------------------|--|
| Mode | STILL |
| Subject | Clear chart (Color reproduction adjustment frame) |
| Adjustment Page | F |
| Adjustment Address | 9D, 9E |

Note 1: Perform “Auto White Balance Standard Data Input” and “Auto White Balance Adjustment” before this adjustment.

Note 2: Check that the data of page: 6, address: 02 is “00”.
If not, turn the power of unit OFF/ON.

Adjusting method:

| Order | Page | Address | Data | Procedure |
|-------|------|---------|------|---|
| 1 | 0 | 01 | 01 | |
| 2 | 5 | F1 | FF | |
| 3 | D | 63 | 40 | Press PAUSE button. |
| 4 | | | | Perform “Data setting during camera system adjustment”. (Refer to page 5-13) |
| 5 | F | 27 | | Note down the data. |
| 6 | F | 27 | 80 | Press PAUSE button. |
| 7 | 6 | 01 | 11 | Press PAUSE button. |
| 8 | 6 | 13 | 88 | Press PAUSE button. |
| 9 | 6 | 01 | D1 | Press PAUSE button. (Note 3) |
| 10 | 6 | 02 | | Check the data changes to “01”. |

Note 3: The adjustment data will be automatically input to page: F, address: 9D and 9E.

Processing after Completing Adjustment:

| Order | Page | Address | Data | Procedure |
|-------|------|---------|------|---|
| 1 | 6 | 01 | 00 | Press PAUSE button. |
| 2 | F | 27 | | Set data noted down at step 5, and press PAUSE button. |
| 3 | 6 | 13 | 00 | Press PAUSE button. |
| 4 | 5 | F1 | 00 | |
| 5 | D | 63 | 00 | Press PAUSE button. |
| 6 | | | | Release the data setting performed at step 4. (Refer to page 5-13) |
| 7 | 0 | 01 | 00 | |

11. Color Reproduction Adjustment

Adjust the color separation matrix coefficient so that proper color reproduction is produced.

| | |
|--------------------|--|
| Mode | STILL |
| Subject | Color bar chart (Color reproduction adjustment frame) |
| Adjustment Page | F |
| Adjustment Address | 41 to 48, 5C to 5F |

Note 1: Perform “Auto White Balance Reference Data Input” before this adjustment.

Note 2: Check that the data of page: 6, address: 02 is “00”.
If not, turn the power of unit OFF/ON.

Adjusting method:

| Order | Page | Address | Data | Procedure |
|-------|------|---------|------|---|
| 1 | 0 | 01 | 01 | |
| 2 | 5 | F1 | FF | |
| 3 | D | 63 | 40 | Press PAUSE button. |
| 4 | | | | Perform “Data setting during camera system adjustment”. (Refer to page 5-13) |
| 5 | 6 | 01 | AB | Press PAUSE button. |
| 6 | 6 | 01 | A9 | Press PAUSE button (Note 3) |
| 7 | 6 | 02 | | Check the data changes to “01”. |

Note 3: The adjustment data will be automatically input to page: F, address: 41 to 48 and 5C to 5F.

Processing after Completing Adjustment:

| Order | Page | Address | Data | Procedure |
|-------|------|---------|------|---|
| 1 | 6 | 01 | 00 | Press PAUSE button. |
| 2 | 5 | F1 | 00 | |
| 3 | D | 63 | 00 | Press PAUSE button. |
| 4 | | | | Release the data setting performed at step 4. (Refer to page 5-13) |
| 5 | 0 | 01 | 00 | |
| 6 | | | | Perform “Color Reproduction Check”. |

12. Color Reproduction Check

| | |
|----------------------|--|
| Mode | STILL |
| Subject | Color bar chart (Color reproduction adjustment frame) |
| Measurement Point | Video terminal of A/V OUT jack (75 Ω terminated) |
| Measuring Instrument | Vectorscope |
| Specified Value | All color luminance points should settle within each color reproduction frame. |

Menu setting:

- VIDEO OUT of SET UP menu
 NTSC (NTSC mode)
 PAL (PAL mode)

Checking method:

| Order | Page | Address | Data | Procedure |
|-------|------|---------|------|---|
| 1 | 0 | 01 | 01 | |
| 2 | 5 | F1 | FF | |
| 3 | D | 63 | 40 | Press PAUSE button. |
| 4 | | | | Perform "Data setting during camera system adjustment". (Refer to page 5-13) |
| 5 | 6 | 10 | 01 | |
| 6 | E | 52 | | Note down the data. |
| 7 | E | 52 | 0A | Press PAUSE button. |
| 8 | 6 | 01 | 0F | Press PAUSE button. |
| 9 | | | | Check the each color luminance point is in each color reproduction frame. |

Processing after Completing Adjustment:

| Order | Page | Address | Data | Procedure |
|-------|------|---------|------|--|
| 1 | 6 | 01 | 00 | Press PAUSE button. |
| 2 | 6 | 10 | 00 | |
| 3 | E | 52 | | Set data noted down at step 6, and press PAUSE button. |
| 4 | 5 | F1 | 00 | |
| 5 | D | 63 | 00 | Press PAUSE button. |
| 6 | | | | Release the data setting performed at step 4. (Refer to page 5-13) |
| 7 | 0 | 01 | 00 | |

For NTSC mode

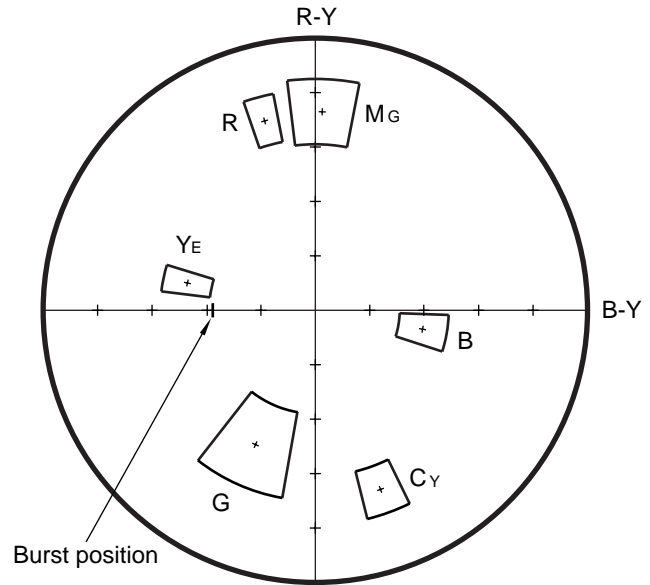

Fig. 5-1-17

For PAL mode

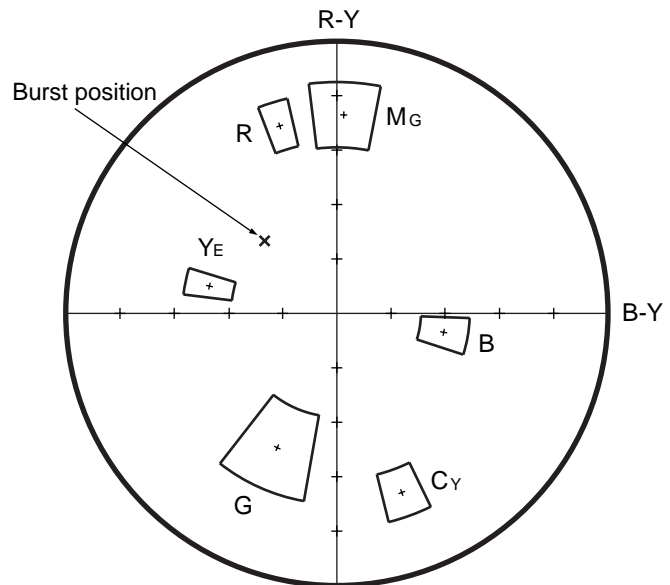

Fig. 5-1-18

13. Auto White Balance Check

| | | |
|----------------------|--|---|
| Mode | STILL | |
| Subject | Clear chart (Color reproduction adjustment frame) | |
| Measurement Point | Displayed data of of Page: 1 (Note 2) | Video terminal A/V OUT jack (75 Ω terminated) |
| Measuring Instrument | Adjustment remote commander | Vectorscope |
| Specified Value | R ratio: 3E00 to 4200 B ratio: 3E00 to 4200 | Fig. 5-1-19 (A) and (B) |

Note 1: Refer to “Picture Frame Setting” for XH, XL, YH and YL.

Note 2: The right four digits of the page: 1 displayed data of the adjusting remote commander.

1:XX:XX

————— Displayed data

Checking method:

| Order | Page | Address | Data | Procedure |
|-------------------------------------|------|---------|------|--|
| 1 | | | | Check that the lens is not covered with either filter. |
| 2 | 0 | 01 | 01 | |
| 3 | 5 | F1 | FF | |
| 4 | D | 63 | 40 | Press PAUSE button. |
| 5 | | | | Perform “Data setting during camera system adjustment”. (Refer to page 5-13) |
| 6 | 6 | 90 | 00 | |
| 7 | 6 | 91 | 04 | |
| 8 | 6 | 92 | 00 | |
| 9 | 6 | 93 | 30 | |
| 10 | 6 | 6C | 01 | |
| 11 | 6 | 2C | 01 | |
| 12 | 6 | 01 | 79 | Press PAUSE button. |
| 13 | | | | Wait for 3 seconds. |
| INDOOR data check | | | | |
| 14 | E | 52 | | Note down the data. |
| 15 | E | 52 | 1A | Press PAUSE button. |
| 16 | 6 | 01 | 0F | Press PAUSE button. |
| 17 | 0 | 03 | 04 | |
| 18 | 1 | | | Check that the displayed data (Note 2) satisfied the R ratio specified value. |
| 19 | 0 | 03 | 05 | |
| 20 | 1 | | | Check that the displayed data (Note 2) satisfied the B ratio specified value. |
| INDOOR luminance point check | | | | |
| 21 | 0 | 03 | 00 | |
| 22 | | | | Check that the center of the white luminance point within the circle shown Fig 5-1-19 (A). |

| OUTDOOR luminance point check | | | | |
|-------------------------------|---|----|----|---|
| 23 | | | | Place the C14 filter on the lens. |
| 24 | E | 4B | | Note down the data. |
| 25 | E | 4B | 20 | Press PAUSE button. |
| 26 | 6 | 01 | 3F | Press PAUSE button. |
| 27 | | | | Check that the center of the white luminance point settles in the circle shown Fig 5-1-19 (B). |
| 28 | 6 | 90 | XL | (Note 1) |
| 29 | 6 | 91 | XH | (Note 1) |
| 30 | 6 | 92 | YL | (Note 1) |
| 31 | 6 | 93 | YH | (Note 1) |
| 32 | 6 | 6C | 01 | |
| 33 | 6 | 2C | 01 | |
| 34 | 6 | 01 | 79 | Press PAUSE button. |
| 35 | | | | Wait for 3 seconds. |

Processing after Completing Adjustment:

| Order | Page | Address | Data | Procedure |
|-------|------|---------|------|--|
| 1 | 6 | 01 | 00 | Press PAUSE button. |
| 2 | 6 | 6C | 00 | |
| 3 | E | 4B | | Set data noted down at step 24, and press PAUSE button. |
| 4 | E | 52 | | Set data noted down at step 14, and press PAUSE button. |
| 5 | 6 | 2C | 00 | |
| 6 | 5 | F1 | 00 | |
| 7 | D | 63 | 00 | Press PAUSE button. |
| 8 | | | | Release the data setting performed at step 5. (Refer to page 5-13) |
| 9 | 0 | 01 | 00 | |

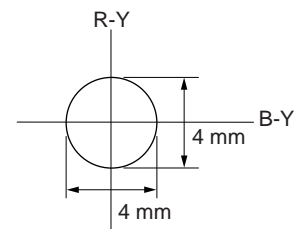

Fig. 5-1-19 (A)

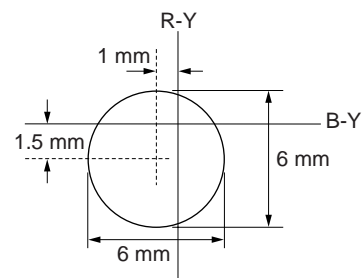

Fig. 5-1-19 (B)

14. Strobe White Balance Adjustment

Adjust the white balance when the strobe light flashed.

| | |
|--------------------|---|
| Mode | STILL |
| Subject | Flash adjustment box (Note 3) (1.0 m from the front of lens) |
| Adjustment Page | F |
| Adjustment Address | 4D, 4E, 64, 69, 6A, 6B |
| Specified Value | Y level data: 64 to 98 (Note 4) R-Y level data: FA to FF or 00 to 06 (Note 5) B-Y level data: FA to FF or 00 to 06 (Note 5) A/D integral value data: 0020 or more (Note 6) |

Note 1: Perform “Flange Back Adjustment”, “Light Level Adjustment” and “Auto White Balance Adjustment” before this adjustment.

Note 2: Perform this adjustment in the Flash adjustment box.

Note 3: Refer to “4. Preparing the Flash adjustment box”. (See page 5-7)

Note 4: Displayed data of page: F, address: 64, of the adjusting remote commander.

F:XX:64

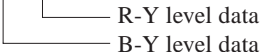

Note 5: The right four digits of the page: 1 displayed data of the adjusting remote commander.

1:XX:XX

Note 6: Displayed data of page: F, address: 69, 6A of the adjusting remote commander.

F:XX:69

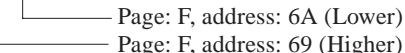
F:XX:6A

XX XX

Note 7: Check that the data of page: 6, address: 02 is “00”. If not, turn the power of unit OFF/ON.

Switch setting:

1) FLASH ON

Checking method:

| Order | Page | Address | Data | Procedure |
|-------|------|---------|------|--|
| 1 | 0 | 01 | 01 | |
| 2 | 5 | F1 | FF | |
| 3 | D | 63 | 40 | Press PAUSE button. |
| 4 | | | | Perform “Data setting during camera system adjustment”. (Refer to page 5-13) |
| 5 | 6 | 90 | 00 | |
| 6 | 6 | 91 | 00 | |
| 7 | 6 | 92 | 00 | |
| 8 | 6 | 93 | 60 | |
| 9 | 6 | 6C | 01 | |
| 10 | 6 | 2C | 01 | |
| 11 | 6 | 01 | 79 | Press PAUSE button. |
| 12 | 7 | 01 | 44 | Press PAUSE button. |
| 13 | | | | Wait for 5 seconds. |

| Order | Page | Address | Data | Procedure |
|-------|------|----------|------|--|
| 14 | 6 | 01 | 67 | Press PAUSE button. |
| 15 | 6 | 02 | | Check the data changes to “01”. |
| 16 | 6 | 01 | 00 | Press PAUSE button. |
| 17 | 6 | 01 | 79 | Press PAUSE button. |
| 18 | | | | Wait for 1 second. |
| 19 | 6 | 01 | 67 | Press PAUSE button. |
| 20 | 6 | 02 | | Check the data changes to “01”. |
| 21 | 6 | 01 | 00 | Press PAUSE button. |
| 22 | 6 | 01 | 79 | Press PAUSE button. |
| 23 | | | | Wait for 1 second. |
| 24 | 6 | 01 | B9 | Press PAUSE button. (Note 8) |
| 25 | 6 | 02 | | Check the data changes to “01”. |
| 26 | 6 | 01 | 00 | Press PAUSE button. |
| 27 | 6 | 01 | 79 | Press PAUSE button. |
| 28 | | | | Wait for 1 second. |
| 29 | 6 | 01 | 67 | PAUSE button. |
| 30 | 6 | 02 | | Check the data changes to “01”. |
| 31 | F | 64 | | Check that the Y level data (Note 4) satisfies the specified value. |
| 32 | 0 | 03 | 02 | |
| 33 | 1 | | | Check that the R-Y, B-Y level data (Note 5) satisfies the specified value. |
| 34 | F | 69 6A | | Check that the A/D integral value data (Note 6) satisfies the specified value. |

Note 8: The adjustment data will be automatically input to page: F, address: 4D, 4E, 64 and 69 to 6B.

Processing after Completing Adjustment:

| Order | Page | Address | Data | Procedure |
|-------|------|---------|------|--|
| 1 | 6 | 2C | 00 | |
| 2 | 6 | 93 | 00 | |
| 3 | 6 | 01 | 00 | Press PAUSE button. |
| 4 | 6 | 6C | 00 | |
| 5 | 7 | 01 | 04 | Press PAUSE button. |
| 6 | 0 | 03 | 00 | |
| 7 | 5 | F1 | 00 | |
| 8 | D | 63 | 00 | Press PAUSE button. |
| 9 | | | | Release the data setting performed at step 4. (Refer to page 5-13) |
| 10 | 0 | 01 | 00 | |

15. CCD Black Defect Compensation

| | |
|----------------------|---|
| Mode | STILL |
| Subject | Clear chart (25 cm from the front of lens) |
| Measurement Point | Displayed data of page: 6, address: 55 |
| Measuring Instrument | Adjusting remote commander |
| Adjustment Page | 7 |
| Adjustment Address | 60 to 87 |

Note 1: Check that there are no dust, no dirt and reflection of the clear chart.

Note 2: Any subject other than the clear chart should be in the screen.

Adjusting method:

| Order | Page | Address | Data | Procedure |
|-------|------|---------|------|---|
| 1 | 0 | 01 | 01 | |
| 2 | 5 | F1 | FF | |
| 3 | D | 63 | 40 | Press PAUSE button. |
| 4 | | | | Perform "Data setting during camera system adjustment". (Refer to page 5-13) |
| 5 | F | DF | | Note down the data. |
| 6 | F | DF | 4C | Press PAUSE button. |
| 7 | 6 | 2C | 01 | |
| 8 | 6 | 90 | 00 | |
| 9 | 6 | 91 | 04 | |
| 10 | 6 | 92 | 00 | |
| 11 | 6 | 93 | 00 | |
| 12 | 6 | 6C | 01 | |
| 13 | 6 | 01 | 79 | Press PAUSE button. |
| 14 | 6 | 30 | 01 | |
| 15 | | | | Wait for 2 seconds. |
| 16 | 6 | 01 | 8D | Press PAUSE button. (Note 3) |
| 17 | 6 | 02 | | Check the data changes to "01". |
| 18 | 6 | 55 | | Check the data. 00 to 0A : Normal 0B to FF : Defective |
| 19 | 6 | 01 | 00 | Press PAUSE button. |
| 20 | F | DF | 5A | Press PAUSE button. |
| 21 | 6 | 01 | 89 | Press PAUSE button. |
| 22 | 6 | 02 | | Check the data changes to "01". |
| 23 | 6 | 55 | | Check the data. 00: Normal 01 to FF: Defective |

Note 3: The adjustment data will be automatically input to page: 7, address: 60 to 87.

Processing after Completing Adjustment:

| Order | Page | Address | Data | Procedure |
|-------|------|---------|------|--|
| 1 | F | DF | | Set data noted down at step 5, and press PAUSE button. |
| 2 | 6 | 01 | 00 | Press PAUSE button. |
| 3 | 6 | 2C | 00 | |
| 4 | 6 | 30 | 00 | |
| 5 | 6 | 6C | 00 | |
| 6 | 6 | 91 | 00 | |
| 7 | 5 | F1 | 00 | |
| 8 | D | 63 | 00 | Press PAUSE button. |
| 9 | | | | Release the data setting performed at step 4. (Refer to page 5-13) |
| 10 | 0 | 01 | 00 | |

16. CCD White Defect Compensation

| | |
|----------------------|---|
| Mode | STILL |
| Subject | Clear chart (25 cm from the front of lens) |
| Measurement Point | Displayed data of page: 6, address: 55 |
| Measuring Instrument | Adjusting remote commander |
| Adjustment Page | 7 |
| Adjustment Address | 88 to A3 |

Note 1: Check that there are no dust, no dirt and reflection of the clear chart.

Note 2: Any subject other than the clear chart should be in the screen.

Adjusting method:

| Order | Page | Address | Data | Procedure |
|-------|------|---------|------|---|
| 1 | 0 | 01 | 01 | |
| 2 | 5 | F1 | FF | |
| 3 | D | 63 | 40 | Press PAUSE button. |
| 4 | | | | Perform "Data setting during camera system adjustment". (Refer to page 5-13) |
| 5 | F | DE | | Note down the data. |
| 6 | F | DE | 1E | Press PAUSE button. |
| 7 | F | E3 | | Note down the data. |
| 8 | F | E3 | 0E | Press PAUSE button. |
| 9 | 6 | 01 | 8B | Press PAUSE button. (Note 3) |
| 10 | 6 | 02 | | Check the data changes to "01". |
| 11 | 6 | 55 | | Check the data. 00 to 7F: Normal 80 to FF: Defective |
| 12 | 6 | 01 | 00 | Press PAUSE button. |
| 13 | F | DE | 1E | Press PAUSE button. |
| 14 | F | E3 | 60 | Press PAUSE button. |
| 15 | 6 | 01 | 87 | Press PAUSE button. |
| 16 | 6 | 02 | | Check the data changes to "01". |
| 17 | 6 | 55 | | Check the data. 00: Normal 01 to FF: Defective |

Note 3: The adjustment data will be automatically input to page: 7, address: 88 to A3.

Processing after Completing Adjustment:

| Order | Page | Address | Data | Procedure |
|-------|------|---------|------|--|
| 1 | F | DE | | Set data noted down at step 5, and press PAUSE button. |
| 2 | F | E3 | | Set data noted down at step 7, and press PAUSE button. |
| 3 | 6 | 01 | 00 | Press PAUSE button. |
| 4 | 5 | F1 | 00 | |
| 5 | D | 63 | 00 | Press PAUSE button. |
| 6 | | | | Release the data setting performed at step 4. (Refer to page 5-13) |
| 7 | 0 | 01 | 00 | |

1-5. LCD SYSTEM ADJUSTMENTS

Before perform the camera system adjustments, check that the specified values of “VIDEO SYSTEM ADJUSTMENTS” are satisfied.

Note 1: Taken an extreme care not to destroy the liquid crystal display module by static electricity when replacing it.

Note 2: Set the LCD BRIGHT (Menu display) to the center.

[Adjusting connector]

Most of the measuring points for adjusting the LCD system are concentrated in CN 881 of the PD-137 board.

Connect the Measuring Instruments via the CPC-9 jig (J-6082-393-C).

The following table shows the Pin No. and signal name of CN 881.

| Pin No. | Signal Name | Pin No. | Signal Name |
|---------|-------------|---------|-------------|
| 1 | BL_L1 | 10 | UNREG |
| 2 | BL_L2 | 11 | LANC IN |
| 3 | N. C. | 12 | LANC OUT |
| 4 | REG_GND | 13 | MAKER_RECOG |
| 5 | N. C. | 14 | PF7 |
| 6 | N. C. | 15 | TXD |
| 7 | HSY | 16 | RXD |
| 8 | PEARL_COM | 17 | RESET |
| 9 | VG | 18 | VDD |

[LCD type check]

By measuring the resistor value between Pin ⑬ of CN881 and Pin ④ of CN881, the type LCD can be discriminated.

PD-137 board CN881

| Resistor value | LCD type |
|----------------|----------|
| 10 kΩ | TYPE SA |
| 22 kΩ | TYPE ST |

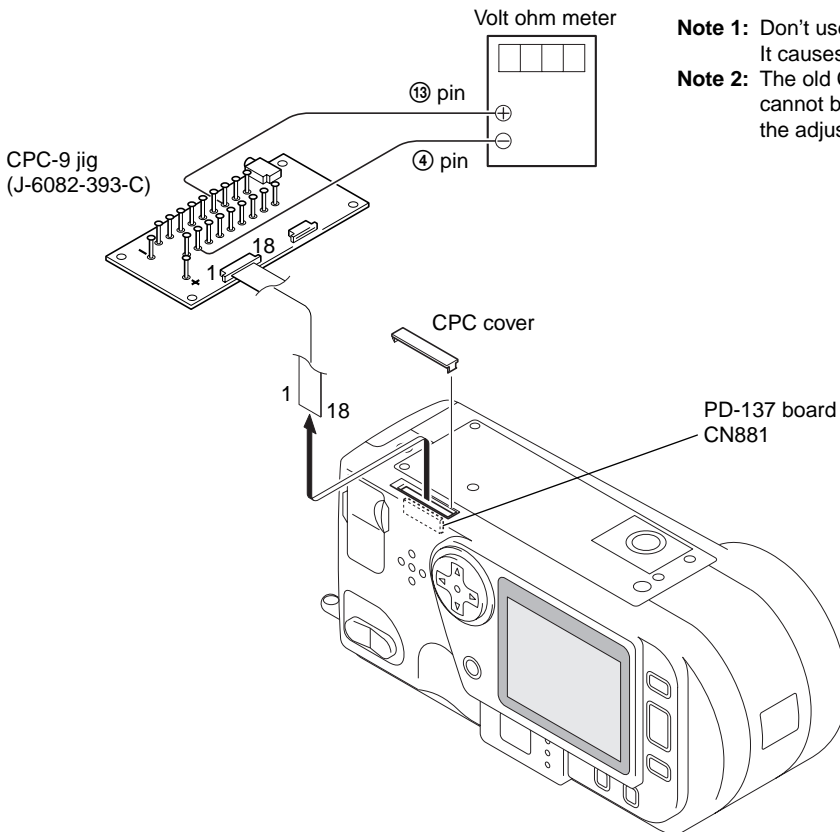

Note 1: Don't use the 12 pin flexible board of CPC-9 jig. It causes damage to the unit.

Note 2: The old CPC-9 jig (Parts code: J-6082-393-B) cannot be used, because it cannot operate the adjustment remote commander.

Fig. 5-1-20

1. LCD Initial Data Input

| | |
|--------------------|---------------------|
| Mode | PLAY |
| Signal | Arbitrary |
| Adjustment Page | D |
| Adjustment Address | D0 to DA , DC to DF |

Adjusting method:

- 1) Select page: 0, address: 01, and set data: 01.
- 2) Select page: D, and enter the data given in the following table.

Note: Press the PAUSE button each time the data are set, as the data are written to non-volatile memory (EEPROM).

| Address | Data | | Remark |
|---------|---------|---------|-------------------------|
| | TYPE ST | TYPE SA | |
| D0 | 20 | 20 | Bright Adjustment |
| D1 | 58 | 62 | Color Adjustment |
| D2 | A0 | A0 | White Blance Adjustment |
| D3 | 88 | 88 | |
| D4 | D0 | D0 | Contrast Adjustment |
| D5 | 90 | 90 | Black Limit Adjustment |
| D6 | 90 | 90 | VG Center Adjustment |
| D7 | 60 | 70 | VCO Adjustment (NTSC) |
| D8 | 90 | 98 | V-COM Adjustment |
| D9 | B3 | B3 | Fixed value |
| DA | 7F | 9A | |
| DC | B3 | B3 | |
| DD | 80 | 90 | VCO Adjustment (PAL) |
| DE | 43 | 43 | Fixed value |
| DF | 00 | 00 | |

Processing after Completing Adjustments:

- 1) Select page: 0, address: 01, and set data: 00.

2. VCO Adjustment (PD-137 Board)

Set the VCO free-run frequency. If deviated, the LCD screen will be blurred.

| | |
|----------------------|---|
| Mode | PLAY |
| Signal | Arbitrary |
| Measurement Point | CH1: Pin ⑦ of CN881 (HSY) CH2: Video terminal of A/V OUTjack (75 Ω terminated) |
| Measuring Instrument | Oscilloscope |
| Adjustment Page | D |
| Adjustment Address | D7 (NTSC) DD (PAL) |
| Specified Value | T = 2.04 ± 0.1 μs (TYPE ST) T = 1.92 ± 0.1 μs (TYPE SA) |

Menu setting:

- VIDEO OUT of SET UP menu
..... NTSC (NTSC mode)
(This adjustment must be performed in NTSC mode, so don't set the menu setting to "PAL")

Adjusting method:

| Order | Page | Address | Data | Procedure |
|-------|------|---------|----------|---|
| 1 | 0 | 01 | 01 | |
| 2 | D | D7 | | Change the data and set the phase difference (T) to the specified value. |
| 3 | D | D7 | | Press PAUSE button. |
| 4 | D | D7 | | Read the data and this data is named D_{D7} |
| 5 | | | | Conver D_{D7} to decimal notation, and obtain D_{D7}' (Note) |
| 6 | | | | Calculate D_{DD}' using following equations (decimal calculation) $D_{DD}' = D_{D7}' + 26$ (TYPE ST) $D_{DD}' = D_{D7}' + 40$ (TYPE SA) |
| 7 | | | | Conver D_{DD}' to a hexadecimal number, and obtain D_{DD} (Note) |
| 8 | D | DD | D_{DD} | Press PAUSE button. |

Note: Refer to table 5-2-2. "Hexadecimal-decimal conversion table"

Processing after Completing Adjustments:

| Order | Page | Address | Data | Procedure |
|-------|------|---------|------|-----------|
| 1 | 0 | 01 | 00 | |

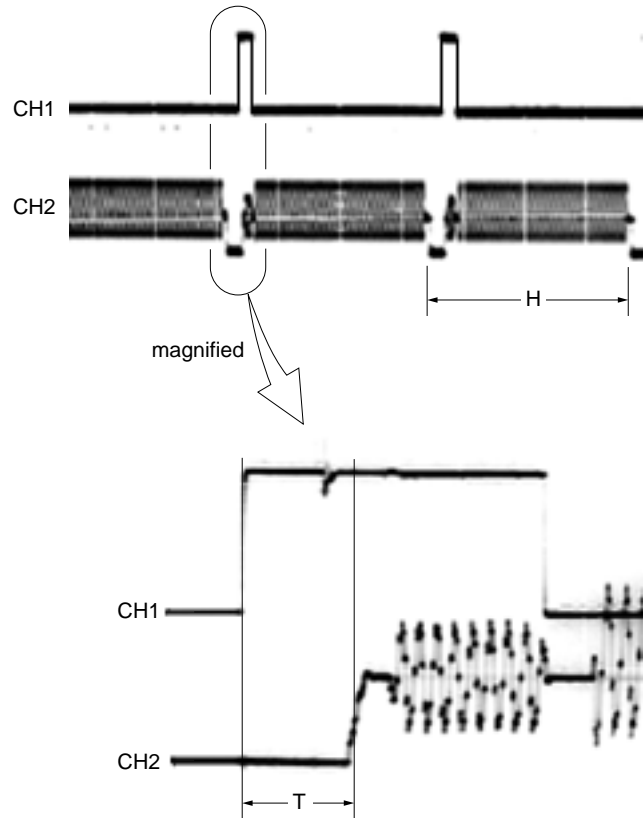

T: Between the center of HSY signal rising and VIDEO SYNC signal rising

Fig. 5-1-21

3. Black Limit Adjustment (PD-137 Board)

Set the maximum amplitude of the RGB decoder for driving the LCD to the specified value.

If deviated, the LCD screen image will be blackish or saturated (whitish).

| | |
|----------------------|--|
| Mode | PLAY |
| Signal | Arbitrary |
| Measurement Point | Pin ⑨ of CN881 (VG) External trigger: Pin ⑧ of CN881 (PEARL COM) |
| Measuring Instrument | Oscilloscope |
| Adjustment Page | D |
| Adjustment Address | D5 |
| Specified Value | A = 8.20 ± 0.1 V _{p-p} (TYPE ST) A = 7.40 ± 0.1 V _{p-p} (TYPE SA) |

Adjusting method:

| Order | Page | Address | Data | Procedure |
|-------|------|---------|------|---|
| 1 | 0 | 01 | 01 | |
| 2 | 5 | F1 | 03 | |
| 3 | D | D0 | | Note down the data. |
| 4 | D | D0 | 20 | Press PAUSE button. |
| 5 | D | D5 | | Change the data and set the voltage (A) to the specified value. |
| 6 | D | D5 | | Press PAUSE button. |

Processing after Completing Adjustments:

| Order | Page | Address | Data | Procedure |
|-------|------|---------|------|--|
| 1 | 5 | F1 | 00 | |
| 2 | D | D0 | | Set data noted down at step 3, and press PAUSE button. |
| 3 | 0 | 01 | 00 | |

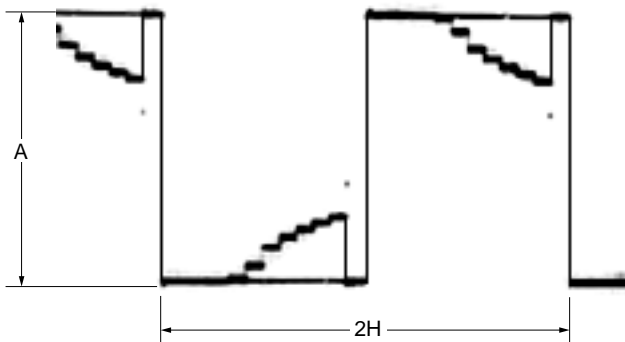

A: Between the reversed waveform peak and non-reversed waveform peak

Fig. 5-1-22

4. Bright Adjustment (PD-137 Board)

Set the amplitude of the RGB decoder for driving the LCD to the specified value.

If deviated, the LCD screen image will be blackish or saturated (whitish).

| | |
|----------------------|--|
| Mode | PLAY |
| Signal | Arbitrary |
| Measurement Point | Pin ⑨ of CN881 (VG) External trigger: Pin ⑧ of CN881 (PEARL COM) |
| Measuring Instrument | Oscilloscope |
| Adjustment Page | D |
| Adjustment Address | D0 |
| Specified Value | A = 7.96 ± 0.1 V _{p-p} (TYPE ST) A = 7.00 ± 0.1 V _{p-p} (TYPE SA) |

Adjusting method:

| Order | Page | Address | Data | Procedure |
|-------|------|---------|------|---|
| 1 | 0 | 01 | 01 | |
| 2 | 5 | F1 | 03 | |
| 3 | D | D0 | | Change the data and set the voltage (A) to the specified value. |
| 4 | D | D0 | | Press PAUSE button. |

Processing after Completing Adjustments:

| Order | Page | Address | Data | Procedure |
|-------|------|---------|------|-----------|
| 1 | 5 | F1 | 00 | |
| 2 | 0 | 01 | 00 | |

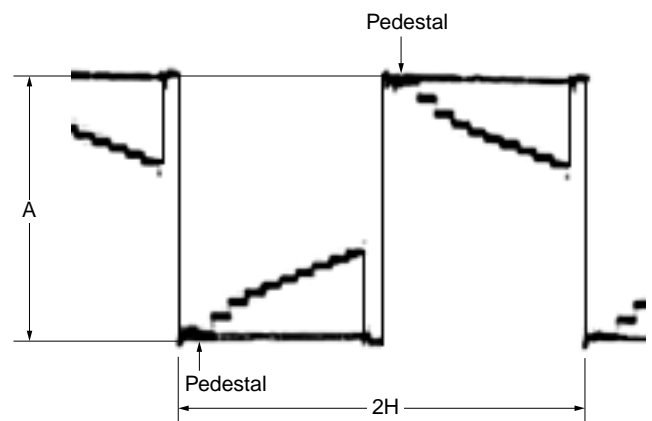

A: Between the reversed waveform pedestal and non-reversed waveform pedestal

Fig. 5-1-23

5. Contrast Adjustment (PD-137 Board)

Set the level of the VIDEO signal for driving the LCD to the specified value.

If deviated, the LCD screen image will be blackish or saturated (whitish).

| | |
|----------------------|--|
| Mode | PLAY |
| Signal | Arbitrary |
| Measurement Point | Pin ⑨ of CN881 (VG) External trigger: Pin ⑧ of CN881 (PEARL COM) |
| Measuring Instrument | Oscilloscope |
| Adjustment Page | D |
| Adjustment Address | D4 |
| Specified Value | A = 2.50 ± 0.05 Vp-p (TYPE ST) A = 2.24 ± 0.05 Vp-p (TYPE SA) |

Adjusting method:

| Order | Page | Address | Data | Procedure |
|-------|------|---------|------|---|
| 1 | 0 | 01 | 01 | |
| 2 | 5 | F1 | 03 | |
| 3 | D | D4 | | Change the data and set the voltage (A) to the specified value. |
| 4 | D | D4 | | Press PAUSE button. |

Processing after Completing Adjustments:

| Order | Page | Address | Data | Procedure |
|-------|------|---------|------|-----------|
| 1 | 5 | F1 | 00 | |
| 2 | 0 | 01 | 00 | |

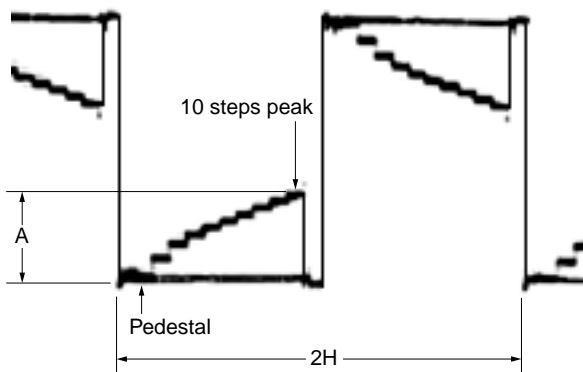

A: Between the pedestal and 10 setps peak

Fig. 5-1-24

6. Color Adjustment (PD-137 Board)

Set the color saturation to the standard value.

If, deviated, the color will be dark or light.

| | |
|----------------------|--|
| Mode | PLAY |
| Signal | Arbitray |
| Measurement Point | Pin ⑨ of CN881 (VG) External trigger: Pin ⑧ of CN881 (PEARL COM) |
| Measuring Instrument | Oscilloscope |
| Adjustment Page | D |
| Adjustment Address | D1 |
| Specified Value | A = 444 ± 50 mVp-p (TYPE ST) A = 308 ± 50 mVp-p (TYPE SA) |

Adjusting method:

| Order | Page | Address | Data | Procedure |
|-------|------|---------|------|---|
| 1 | 0 | 01 | 01 | |
| 2 | 5 | F1 | 04 | |
| 2 | D | D1 | | Change the data and set the voltage (A) to the specified value. |
| 4 | D | D1 | | Press PAUSE button. |

Processing after Completing Adjustments:

| Order | Page | Address | Data | Procedure |
|-------|------|---------|------|-----------|
| 1 | 5 | F1 | 00 | |
| 2 | 0 | 01 | 00 | |

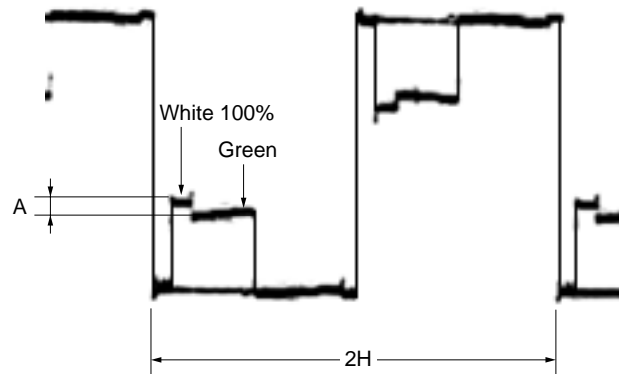

A: Between the white 100% (Reference level) and green

Fig. 5-1-25

7. VG Center Adjustment (PD-137 Board)

Set the center of VG signal for driving the LCD to the specified value.

| | |
|----------------------|--|
| Mode | PLAY |
| Signal | Arbitrary |
| Measurement Point | Pin ⑨ of CN881 (VG) |
| Measuring Instrument | Digital voltmeter |
| Adjustment Page | D |
| Adjustment Address | D6 |
| Specified Value | A = 7.00 ± 0.05 V (TYPE ST) A = 6.00 ± 0.05 V (TYPE SA) |

Adjusting method:

| Order | Page | Address | Data | Procedure |
|-------|------|---------|------|--|
| 1 | 0 | 01 | 01 | |
| 2 | 5 | F1 | 02 | |
| 3 | D | D6 | | Change the data and set the DC voltage (A) to the specified value. |
| 4 | D | D6 | | Press PAUSE button. |

Processing after Completing Adjustments:

| Order | Page | Address | Data | Procedure |
|-------|------|---------|------|-----------|
| 1 | 5 | F1 | 00 | |
| 2 | 0 | 01 | 00 | |

8. V-COM Adjustment (PD-137 Board)

Set the DC bias of the common electrode drive signal of LCD to the specified value.

If deviated, the LCD display will be move, producing flicker and conspicuous vertical lines.

| | |
|----------------------|--|
| Mode | PLAY |
| Signal | Arbitrary |
| Measurement Point | Check on LCD screen |
| Measuring Instrument | |
| Adjustment Page | D |
| Adjustment Address | D8 |
| Specified Value | The brightness difference between the section-A and section-B is minimum |

Note: Perform “Bright Adjustment” and “Contrast Adjustment” before this adjustment.

Adjusting method:

| Order | Page | Address | Data | Procedure |
|-------|------|---------|----------|---|
| 1 | 0 | 01 | 01 | |
| 2 | 5 | F1 | 02 | |
| 3 | 2 | 10 | 02 | |
| 4 | D | D8 | | Change the data so that brightness of the section A and section B is equal. |
| 5 | D | D8 | | TYPE SA: Press PAUSE button, and proceed to “Processing after Completing Adjustments”. TYPE ST: Proceed to step 6 to 11. |
| 6 | D | D8 | | Read the data and this data is named Dref |
| 7 | | | | Conver Dref to decimal notation, and obtain Dref’ (Note) |
| 8 | | | | Calculate D_{D8}' using following equations (decimal calculation) |
| 9 | | | | $D_{D8}' = Dref' - 9$ |
| 10 | | | | Conver D_{D8}' to a hexadecimal number, and obtain D_{D8} (Note) |
| 11 | D | D8 | D_{D8} | Press PAUSE button. |

Note: Refer to table 5-2-2. “Hexadecimal-decimal conversion table”

Processing after Completing Adjustments:

| Order | Page | Address | Data | Procedure |
|-------|------|---------|------|-----------|
| 1 | 5 | F1 | 00 | |
| 2 | 2 | 10 | 00 | |
| 3 | 0 | 01 | 00 | |

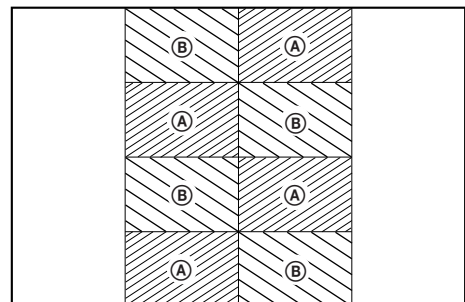

Fig. 5-1-26

9. White Balance Adjustment (PD-137 Board)

Correct the white balance.

If deviated, the LCD screen color cannot be reproduced.

| | |
|----------------------|--------------------------------|
| Mode | PLAY |
| Signal | Arbitrary |
| Measurement Point | Check on LCD screen |
| Measuring Instrument | |
| Adjustment Page | D |
| Adjustment Address | D2, D3 |
| Specified Value | LCD screen must not be colored |

Note 1: Check the white balance only when replacing the following parts. If necessary, adjust them.

1. LCD panel
2. Light induction plate
3. IC801

Adjusting method:

| Order | Page | Address | Data | Procedure |
|-------|------|----------|----------|---|
| 1 | 0 | 01 | 01 | |
| 2 | 5 | F1 | 02 | |
| 3 | D | D2 D3 | A0 88 | Press PAUSE button. (Initial value) |
| 4 | | | | Check that the LCD screen is not colored. If not colored, proceed to "Processing after Completing Adjustments". |
| 5 | D | D2 D3 | | Change the data so that the LCD screen is not colored. (Note 2) |

Note 2: To write in the non-volatile memory (EEPROM), press the PAUSE button each time to set the data.

Processing after Completing Adjustments:

| Order | Page | Address | Data | Procedure |
|-------|------|---------|------|-----------|
| 1 | 5 | F1 | 00 | |
| 2 | 0 | 01 | 00 | |

1-6. SYSTEM CONTROL SYSTEM ADJUSTMENTS

1. Battery End Adjustment

Set the battery end voltage.

If the voltage is incorrect, the life of battery will shorten.

The image at the battery end will also be rough.

| | |
|----------------------|---|
| Mode | STILL |
| Subject | Arbitrary |
| Measurement Point | Displayed data of page: 2, address: 51 |
| Measuring Instrument | Adjusting remote commander |
| Adjustment Page | D |
| Adjustment Address | 90 to 94 |

Connection:

- 1) Connect the regulated power supply and the digital voltmeter to the battery terminal as shown in Fig. 5-1-27.

Preparations before adjustment:

- 1) Adjust the output voltage of the regulated power supply so that the digital voltmeter display is 3.6 ± 0.1 Vdc.
- 2) Turn off the power supply.
- 3) Turn the HOLD switch of the adjusting remote commander.
- 4) Turn on the power supply.
- 5) Insert the memory stick to the unit, and set the STILL mode.
- 6) Set the FOCUS switch in MANUAL mode.

Adjusting method:

| Order | Page | Address | Data | Procedure |
|-------|------|---------|----------|---|
| 1 | 0 | 01 | 01 | |
| 2 | 6 | 2C | 01 | |
| 3 | | | | Decrease the output voltage of the regulated power supply so that digital voltmeter display is 3.1 ± 0.01 Vdc. |
| 4 | 2 | 51 | | Check the data. 74 to 86 : Normal 00 to 73, 87 to FF: Defective |
| 5 | 2 | 51 | | Read the data, and this data is named Dref. |
| 6 | D | 90 | Dref | Press PAUSE button. |
| 7 | | | | Convert Dref to decimal notation and obtain Dref'. (Note) |
| 8 | | | | Calculate D_{91}' , D_{92}' , D_{93}' and D_{94}' using following equations(decimal calculation) $D_{91}' = Dref' + 3$ $D_{92}' = Dref' + 10$ $D_{93}' = Dref' + 10$ $D_{94}' = Dref' + 10$ |
| 9 | | | | Convert D_{91}' , D_{92}' , D_{93}' and D_{94}' to a hexadecimal number, and obtain D_{91} , D_{92} , D_{93} and D_{94} (Note) |
| 10 | D | 91 | D_{91} | Press PAUSE button. |
| 11 | D | 92 | D_{92} | Press PAUSE button. |
| 12 | D | 93 | D_{93} | Press PAUSE button. |
| 13 | D | 94 | D_{94} | Press PAUSE button. |

Note: Refer to table 5-2-2. "Hexadecimal-decimal conversion table"

Processing after Completing Adjustments:

| Order | Page | Address | Data | Procedure |
|-------|------|---------|------|-----------|
| 1 | 6 | 2C | 00 | |
| 2 | 0 | 01 | 00 | |

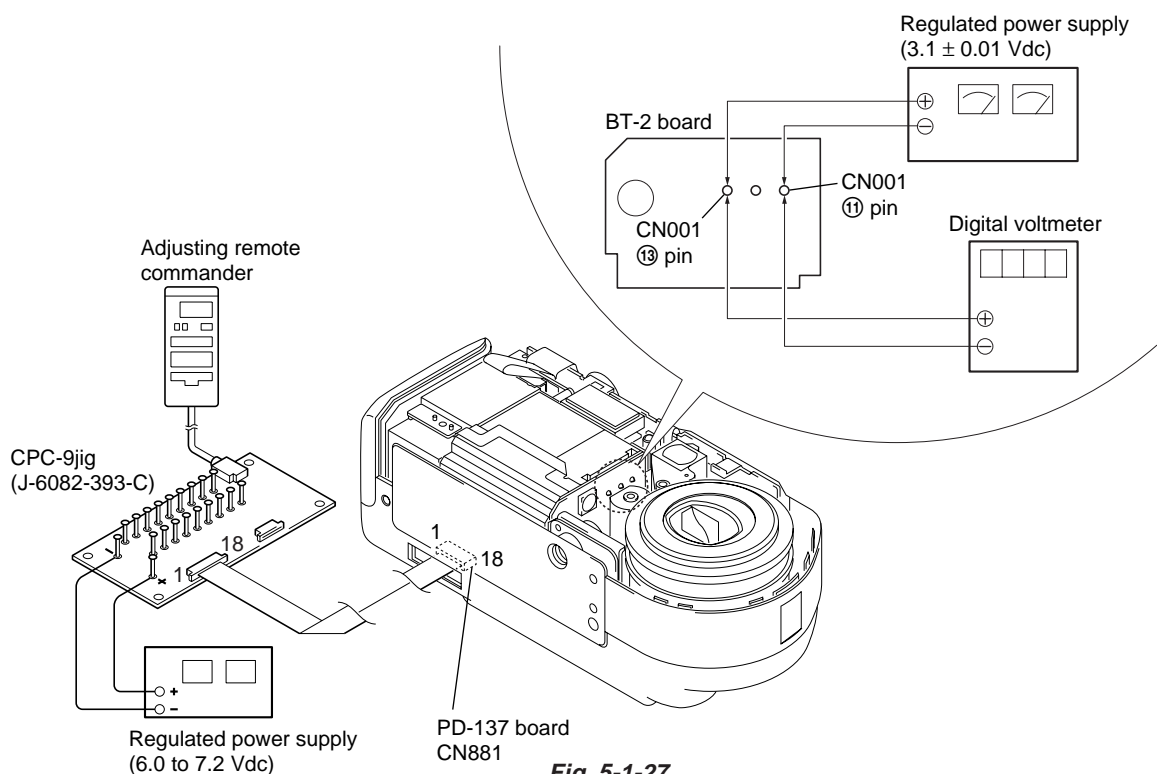

Fig. 5-1-27

5-2. SERVICE MODE

2-1. ADJUSTING REMOTE COMMANDER

The adjusting remote commander is used for changing the calculation coefficient in signal processing, EVR data, etc. The adjusting remote commander performs bi-directional communication with the unit using the remote commander signal line (LANC). The resultant data of this bi-directional communication is written in the non-volatile memory.

1. Used the Adjusting Remote Commander

- 1) Connect the adjusting remote commander to the CN881 on the PD-137 board via CPC-9 jig (J-6082-393-C).
 - 2) Adjust the HOLD switch of the adjusting remote commander to "HOLD" (SERVICE position).
 - 3) Turn on the power with the POWER switch of the unit.
- If it has been properly connected, the LCD on the adjusting remote commander will display as shown in Fig. 5-2-1.

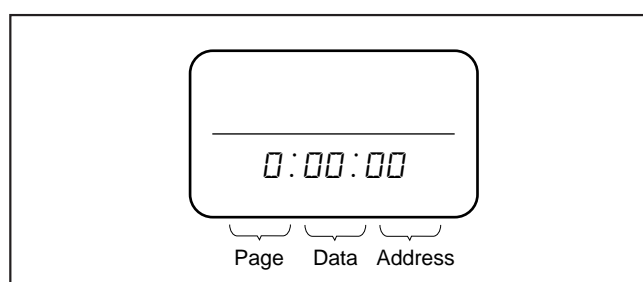

Fig. 5-2-1

- 4) Operate the adjusting remote commander as follows.
 - Changing the page

The page increases when the EDIT SEARCH + button is pressed, and decreases when the EDIT SEARCH – button is pressed. There are altogether 16 pages, from 0 to F.

| | |
|-----------------------------------|---------------------------------------|
| Hexadecimal notation | 0 1 2 3 4 5 6 7 8 9 A B C D E F |
| LCD Display | 0 1 2 3 4 5 6 7 8 9 A b c d E F |
| Decimal notation conversion value | 0 1 2 3 4 5 6 7 8 9 10 11 12 13 14 15 |

Table 5-2-1

- Changing the address

The address increases when the FF (▶▶) button is pressed, and decreases when the REW (▶▶) button is pressed. There are altogether 256 addresses, from 00 to FF.
- Changing the data (Data setting)

The data increases when the PLAY (▶) button is pressed, and decreases when the STOP (■) button is pressed. There are altogether 256 data, from 00 to FF.
- Writing the adjustment data

The PAUSE button must be pressed to write the adjustment data in the nonvolatile memory. (The new adjustment data will not be recorded in the nonvolatile memory if this step is not performed)

2. Precautions upon Using the Adjusting Remote Commander

Mishandling of the adjusting remote commander may erase the correct adjustment data at times. To prevent this, it is recommended that all adjustment data be noted down before beginning adjustments and new adjustment data after each adjustment.

2-2. DATA PROCESS

The calculation of the adjusting remote commander display data (hexadecimal notation) are required for obtaining the adjustment data of some adjustment items. In this case, after converting the hexadecimal notation to decimal notation, calculate and convert the result to hexadecimal notation, and use it as the adjustment data. Table 5-2-2. indicates the hexadecimal notation- the decimal notation, calculation table.

| Hexadecimal notation-Decimal notation | | | | | | | | | | | | | | | | |
|--|-----|-----|-----|-----|-----|-----|-----|-----|-----|-----|-----|-----|-----|-----|-----|-----|
| The lower digits of the hexadecimal notation The upper digits of the hexadecimal notation | 0 | 1 | 2 | 3 | 4 | 5 | 6 | 7 | 8 | 9 | A | B | C | D | E | F |
| | | | | | | | | | | | (A) | (B) | (C) | (D) | (E) | (F) |
| 0 | 0 | 1 | 2 | 3 | 4 | 5 | 6 | 7 | 8 | 9 | 10 | 11 | 12 | 13 | 14 | 15 |
| 1 | 16 | 17 | 18 | 19 | 20 | 21 | 22 | 23 | 24 | 25 | 26 | 27 | 28 | 29 | 30 | 31 |
| 2 | 32 | 33 | 34 | 35 | 36 | 37 | 38 | 39 | 40 | 41 | 42 | 43 | 44 | 45 | 46 | 47 |
| 3 | 48 | 49 | 50 | 51 | 52 | 53 | 54 | 55 | 56 | 57 | 58 | 59 | 60 | 61 | 62 | 63 |
| 4 | 64 | 65 | 66 | 67 | 68 | 69 | 70 | 71 | 72 | 73 | 74 | 75 | 76 | 77 | 78 | 79 |
| 5 | 80 | 81 | 82 | 83 | 84 | 85 | 86 | 87 | 88 | 89 | 90 | 91 | 92 | 93 | 94 | 95 |
| 6 | 96 | 97 | 98 | 99 | 100 | 101 | 102 | 103 | 104 | 105 | 106 | 107 | 108 | 109 | 110 | 111 |
| 7 | 112 | 113 | 114 | 115 | 116 | 117 | 118 | 119 | 120 | 121 | 122 | 123 | 124 | 125 | 126 | 127 |
| 8 | 128 | 129 | 130 | 131 | 132 | 133 | 134 | 135 | 136 | 137 | 138 | 139 | 140 | 141 | 142 | 143 |
| 9 | 144 | 145 | 146 | 147 | 148 | 149 | 150 | 151 | 152 | 153 | 154 | 155 | 156 | 157 | 158 | 159 |
| A (A) | 160 | 161 | 162 | 163 | 164 | 165 | 166 | 167 | 168 | 169 | 170 | 171 | 172 | 173 | 174 | 175 |
| ①→ B (B) | 176 | 177 | 178 | 179 | 180 | 181 | 182 | 183 | 184 | 185 | 186 | 187 | 188 | 189 | 190 | 191 |
| C (C) | 192 | 193 | 194 | 195 | 196 | 197 | 198 | 199 | 200 | 201 | 202 | 203 | 204 | 205 | 206 | 207 |
| D (D) | 208 | 209 | 210 | 211 | 212 | 213 | 214 | 215 | 216 | 217 | 218 | 219 | 220 | 221 | 222 | 223 |
| E (E) | 224 | 225 | 226 | 227 | 228 | 229 | 230 | 231 | 232 | 233 | 234 | 235 | 236 | 237 | 238 | 239 |
| F (F) | 240 | 241 | 242 | 243 | 244 | 245 | 246 | 247 | 248 | 249 | 250 | 251 | 252 | 253 | 254 | 255 |

Note : () indicate the adjusting remote control unit display.

(Example) In the case that the adjusting remote control unit display are BD (BD).
As the upper digit of the hexadecimal notation is B (B), and the lower digit is D (D), the intersection “189” of the ① and ② in the above table is the decimal notation to be calculated.

Table 5-2-2

2-3. SERVICE MODE

1. Setting the Test Mode

| | |
|--------|------------|
| Page D | Address 10 |
|--------|------------|

| Data | Function |
|------|----------------------------|
| 00 | Normal |
| 01 | Forced STILL mode power ON |
| 02 | Forced PLAY mode power ON |
| 03 | Forced MOVIE mode power ON |

- Before setting the data, select page: 0, address: 01, and set data: 01.
- For page D, the data set is recorded in the non-volatile memory by pressing the PAUSE button of the adjusting remote commander. In this case, take note that the test mode will not be exited even when the main power is turned off.
- After completing adjustments/repairs, be sure to return the data of this address to “00”, and press the PAUSE button of the adjusting remote commander.
Select page: 0, address: 01, and set data: 00.

2. Bit Value Discrimination

Bit values must be discriminated using the display data of the adjusting remote commander for following items. Use the table below to discriminate if the bit value is “1” or “0”

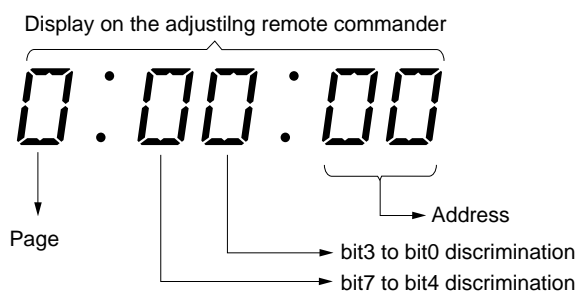

| Display on the Adjusting remote commander | Bit values | | | |
|---|--------------|--------------|--------------|--------------|
| | bit3 or bit7 | bit2 or bit6 | bit1 or bit5 | bit0 or bit4 |
| 0 | 0 | 0 | 0 | 0 |
| 1 | 0 | 0 | 0 | 1 |
| 2 | 0 | 0 | 1 | 0 |
| 3 | 0 | 0 | 1 | 1 |
| 4 | 0 | 1 | 0 | 0 |
| 5 | 0 | 1 | 0 | 1 |
| 6 | 0 | 1 | 1 | 0 |
| 7 | 0 | 1 | 1 | 1 |
| Ⓐ 8 | 1 | 0 | 0 | 0 |
| 9 | 1 | 0 | 0 | 1 |
| A(Ā) | 1 | 0 | 1 | 0 |
| B(b) | 1 | 0 | 1 | 1 |
| C(c) | 1 | 1 | 0 | 0 |
| D(d) | 1 | 1 | 0 | 1 |
| Ⓑ E(Ē) | 1 | 1 | 1 | 0 |
| F(F̄) | 1 | 1 | 1 | 1 |

Example: If “8E” is displayed on the adjusting remote commander, the bit values for bit7 to bit4 are shown in the Ⓐ column, and the bit values for bit3 to bit0 are shown in the Ⓑ column.

3. Switch Check (1)

| | |
|--------|------------|
| Page 2 | Address 43 |
|--------|------------|

| Bit | Function | When bit value=1 | When bit value=0 |
|-----|---------------------------------|------------------|------------------|
| 2 | SHUTTER SW (PW-122 board) | OFF | ON |
| 3 | XSHUTTER LOCK SW (PW-122 board) | OFF | ON |

Using method:

- 1) Select page: 2, address: 43
- 2) By discriminating the bit value of display data, the state of the switches can be discriminated.

4. Switch Check (2)

| | |
|--------|--------------------|
| Page 2 | Addresses 55 to 57 |
|--------|--------------------|

Using method:

- 1) Select page: 2, addresses: 55 to 57.
- 2) By discriminating the display data, the pressed key can be discriminated.

| Address | Data | | | | | | |
|------------------------------|---|--|---|-------------------------------------|--|--|----------|
| | 00 to 14 | 15 to 3B | 3C to 64 | 65 to 91 | 92 to BD | BE to E9 | EA to FF |
| 55 (KEY AD1) (IC404 ㉟) | CONTROL DOWN (PD-137 board) (S882) | CONTROL UP (PD-137 board) (S882) | DISPLAY (PD-137 board) (S881) | VOLUME+ (SW-349 board) (S005) | VOLUME- (SW-349 board) (S007) | | |
| 56 (KEY AD2) (IC404 ㊱) | CONTROL RIGHT (PD-137 board) (S882) | CONTROL LEFT (PD-137 board) (S882) | CONTROL SET (PD-137 board) (S882) | FLASH (SW-349 board) (S002) | MACRO (SW-349 board) (S003) | LCD BACK LIGHT OFF (SW-349 board) (S006) | |
| 57 (KEY AD3) (IC404 ㊲) | | | | | PROGRAM AE (SW-349 board) (S008) | | |

5. LED, LCD Check

| | | |
|--------|------------|---------|
| Page 2 | Address 06 | Data 02 |
|--------|------------|---------|

Using method:

- 1) Select page: 2, address: 06, and set data: 02.
- 2) Check that all LED except for the ACCESS LED are lit and all segments of LCD (display window) are lit.
- 3) Select page: 2, address: 06, and set data: 00.

SECTION 6 REPAIR PARTS LIST

6-1. EXPLODED VIEWS

NOTE:

- -XX and -X mean standardized parts, so they may have some difference from the original one.
- Color Indication of Appearance Parts
Example:
KNOB, BALANCE (WHITE) . . . (RED)
 ↑ ↑
 Parts Color Cabinet's Color
- Items marked "*" are not stocked since they are seldom required for routine service. Some delay should be anticipated when ordering these items.
- The mechanical parts with no reference number in the exploded views are not supplied.
- Accessories are given in the last of the electrical parts list.

The components identified by mark \triangle or dotted line with mark \triangle are critical for safety. Replace only with part number specified.

Les composants identifiés par une marque \triangle sont critiques pour la sécurité. Ne les remplacer que par une pièce portant le numéro spécifié.

6-1-1. UPPER CABINET SECTION

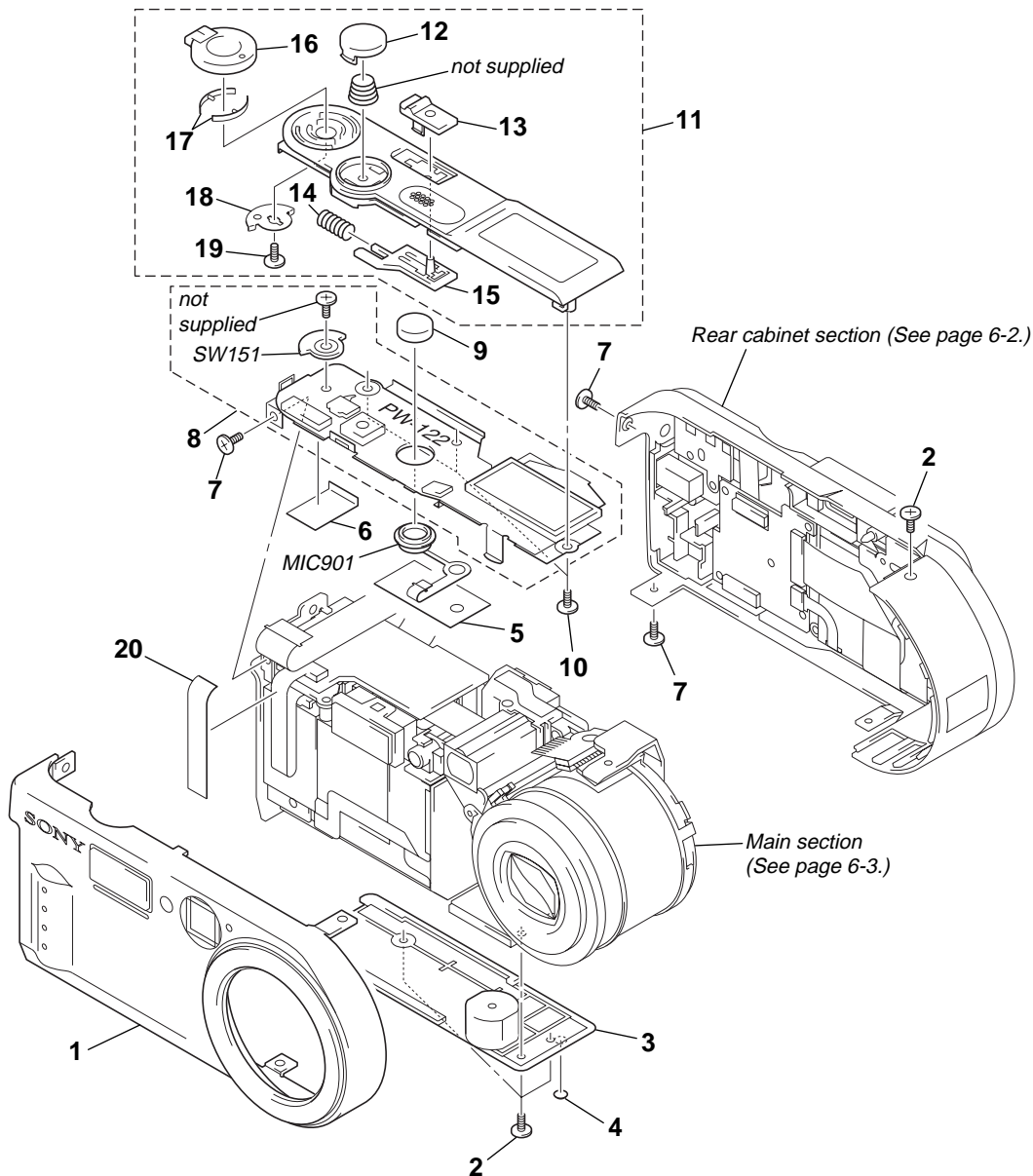

| Ref. No. | Part No. | Description | Remark | Ref. No. | Part No. | Description | Remark |
|----------|--------------|----------------------------|--------|----------|--------------|------------------------|--------|
| 1 | X-3951-025-1 | CABINET (FRONT) ASSY | | 12 | 3-064-263-01 | BUTTON, SHUTTER | |
| 2 | 3-989-735-81 | SCREW (M1.7), LOCK ACE, P2 | | 13 | 3-064-260-01 | KNOB, POWER | |
| 3 | 3-064-242-01 | CABINET (BOTTOM) | | 14 | 3-064-237-01 | SPRING, COMPRESSION | |
| 4 | 3-969-387-01 | FOOT, RUBBER | | 15 | 3-064-266-01 | SLIDER (POWER) | |
| * 5 | 3-064-227-01 | SHEET, MICROPHONE | | 16 | 3-064-259-01 | KNOB, MODE | |
| * 6 | 3-065-229-01 | SHEET (UPPER) | | 17 | X-3946-488-1 | SPRING ASSY, AE LEAF | |
| 7 | 3-989-735-51 | SCREW (M1.7), LOCK ACE, P2 | | 18 | 3-064-496-01 | DISK (MODE) | |
| 8 | A-7096-377-A | PW-122 BLOCK ASSY | | 19 | 3-318-382-21 | SCREW (1.7X3), TAPPING | |
| * 9 | 3-055-971-01 | CUSHION, MICROPHONE | | * 20 | 3-066-383-01 | SHEET, FLEXIBLE FIXED | |
| 10 | 3-318-382-03 | SCREW (1.7), TAPPING | | MIC901 | 1-542-446-11 | MICROPHONE | |
| 11 | X-3951-027-1 | CABINET (UPPER) ASSY | | * SW151 | X-3951-075-1 | SLIDER (MODE) ASSY | |

6-1-2. REAR PANEL SECTION

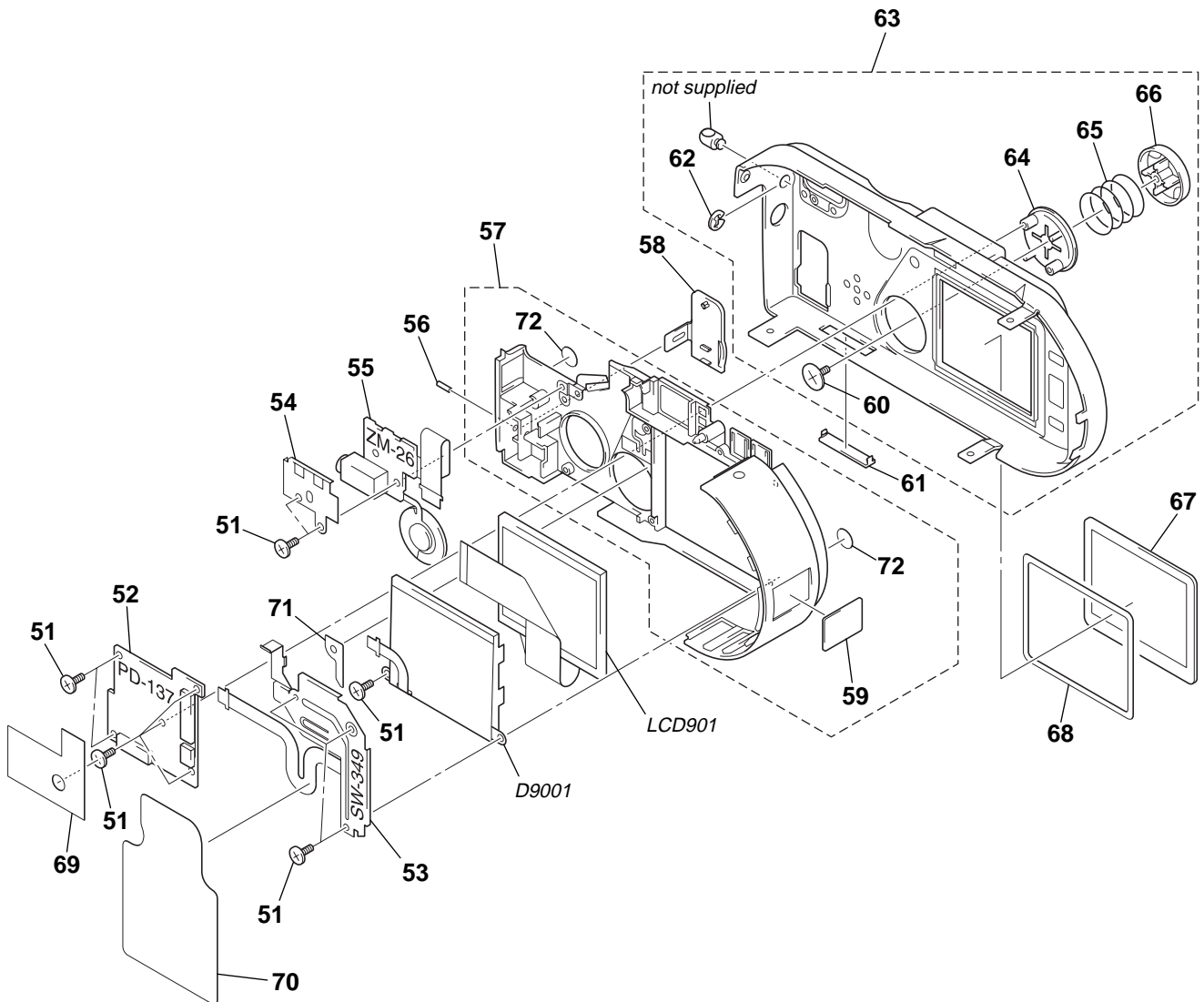

(Note) About PD-137 board and LCD module, discriminate LCD type on the machine referring to page 6, and replace the same type.

| Ref. No. | Part No. | Description | Remark | Ref. No. | Part No. | Description | Remark |
|----------|--------------|---|--------|----------|--------------|---|--------|
| 51 | 3-318-382-03 | SCREW (1.7), TAPPING | | 64 | 3-064-248-01 | HOLDER, F BUTTON | |
| 52 | A-7096-373-A | PD-137 BLOCK ASSY (TYPE ST) | | * 65 | 3-064-250-01 | SPRING, F BUTTON | |
| 52 | A-7096-374-A | PD-137 BLOCK ASSY (TYPE SA) | | 66 | 3-064-247-01 | BUTTON, FUNCTION | |
| 53 | A-7096-375-A | SW-349 BLOCK ASSY | | 67 | 3-064-274-01 | COVER, LCD | |
| * 54 | 3-064-278-01 | SHEET METAL, ZM | | 68 | 3-064-230-01 | SHEET (P), ADHESIVE | |
| 55 | A-7074-603-A | ZM-26 BOARD, COMPLETE | | * 69 | 3-064-233-01 | SHEET (B), INSULATING | |
| * 56 | 3-703-357-02 | PIN, PARALLEL (DIA. 1.6X5) | | * 70 | 3-065-667-01 | SHEET (SW), INSULATING | |
| 57 | X-3951-031-1 | CABINET (REAR) ASSY, INNER (SERVICE) | | * 71 | 3-065-230-01 | SHEET (F), LIGHT INTERCEPTION | |
| 58 | 3-064-281-01 | COVER, JACK | | 72 | 3-064-219-01 | ADHESIVE SHEET (A) | |
| 59 | 3-055-366-01 | MARK, MS | | D9001 | 1-476-330-11 | BLOCK, LIGHT GUIDE PLATE (TYPE ST) | |
| 60 | 3-065-177-01 | SCREW (1.7X3) | | D9001 | 1-476-331-21 | BLOCK, LIGHT GUIDE PLATE (TYPE SA) | |
| 61 | 3-064-225-01 | LID, CPC | | LCD901 | 1-804-206-21 | INDICATOR MODULE, LIQUID CRYSTAL (TYPE SA) | |
| 62 | 7-624-118-01 | RING, RETAINING E-2.5 | | LCD901 | 8-753-050-66 | ACX309AK-1 (TYPE ST) | |
| 63 | X-3951-032-1 | CABINET (REAR) ASSY, ALUMINUM (SERVICE) | | | | | |

6-1-3. MAIN SECTION

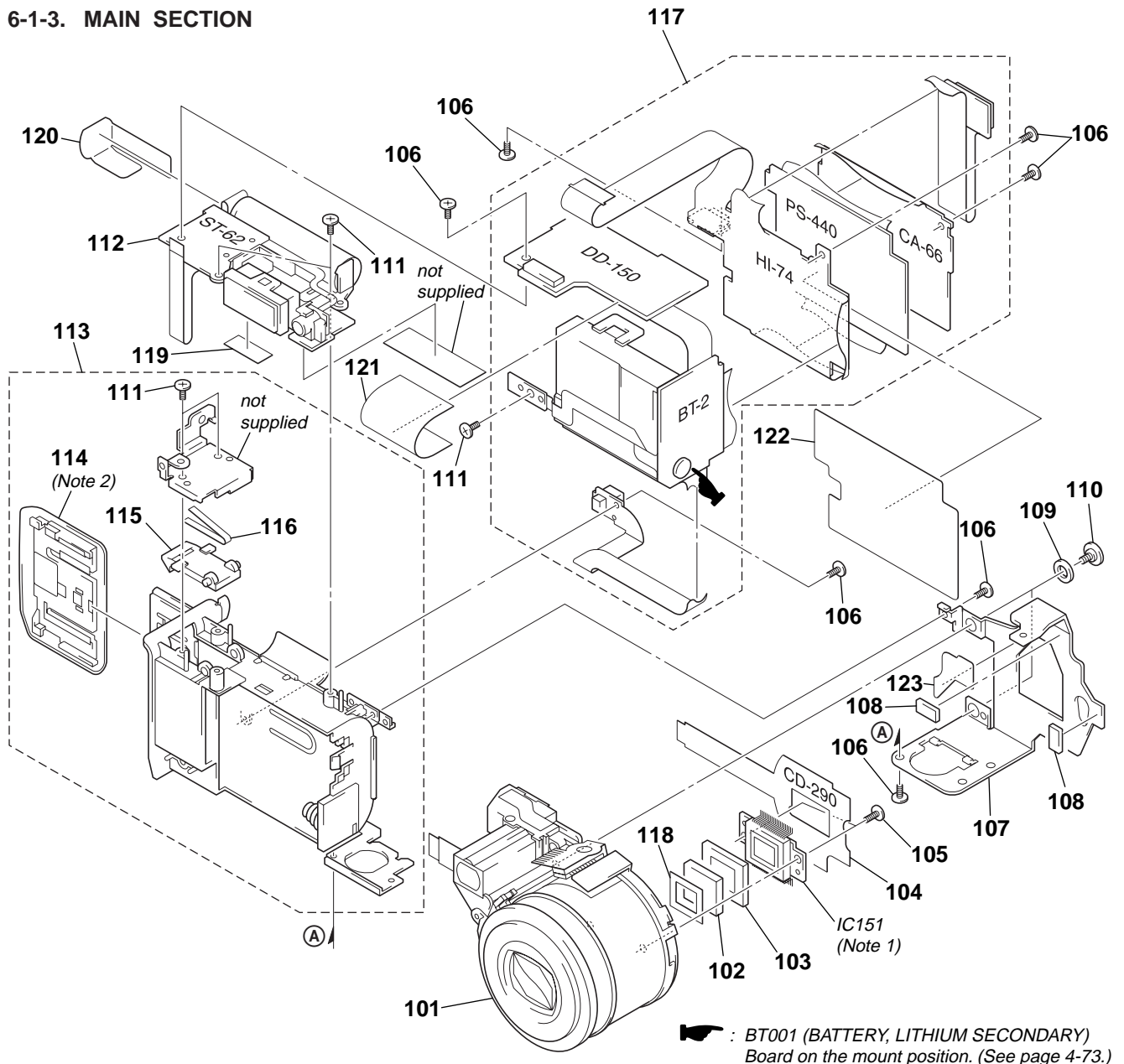

: BT001 (BATTERY, LITHIUM SECONDARY) Board on the mount position. (See page 4-73.)

The components identified by mark Δ or dotted line with mark \triangle are critical for safety. Replace only with part number specified.

Les composants identifiés par une marque Δ sont critiques pour la sécurité. Ne les remplacer que par une pièce portant le numéro spécifié.

(Note 1) Be sure to read "Precautions for Replacement of CCD Imager" on page 4-8 when changing the CCD imager.

(Note 2) Be sure to read "2-1. BT LID ASSEMBLY REPLACING METHOD" on page 2-2 when changing the BT lid Assy.

| Ref. No. | Part No. | Description | Remark | Ref. No. | Part No. | Description | Remark |
|--------------|--------------|-----------------------------|--------|----------|--------------|--|--------|
| 101 | 1-758-517-11 | LENS, VIDEO (98WA) | | 114 | X-3951-282-1 | BT LID ASSY (SERVICE) (Note 2) | |
| 102 | 1-758-516-11 | FILTER BLOCK, OPTICAL | | 115 | 3-064-207-01 | CLAW, BT LOCK | |
| 103 | 3-054-555-01 | RUBBER (K), SEAL | | 116 | 3-064-208-01 | SPRING, BT LOCK | |
| 104 | A-7074-592-A | CD-290 BOARD, COMPLETE | | 117 | A-7074-605-A | MT-60 BOARD, COMPLETE (SERVICE) (BT-2, CA-66, DD-150, HI-74 and PS-440 boards are included in this complete board) | |
| 105 | 3-713-791-41 | SCREW (M1.7X5), TAPPING, P2 | | 118 | 3-065-690-01 | PLATE, LIGHT INTERCEPTION | |
| 106 | 3-989-735-51 | SCREW (M1.7), LOCK ACE, P2 | | * 119 | 3-066-692-01 | SHEET, INSULATING | |
| * 107 | 3-064-244-01 | FRAME, LENS | | 120 | 1-679-962-11 | FP-338 FLEXIBLE BOARD | |
| 108 | 3-064-217-01 | CUSHION, FRAME | | 121 | 3-064-238-01 | SHEET (C), INSULATING | |
| 109 | 3-064-216-01 | CUSHION (L) | | 122 | 3-064-232-01 | SHEET (A), INSULATING | |
| 110 | 3-064-215-01 | SCREW (M1.7), STEP | | * 123 | 3-065-666-01 | SHEET (LF), INSUALTING | |
| 111 | 3-318-382-03 | SCREW (1.7), TAPPING | | IC151 | A-7031-134-A | CCD BLOCK ASSY (CCD IMAGER) (Note 1) | |
| Δ 112 | A-7074-599-A | ST-62 BOARD, COMPLETE | | | | | |
| 113 | X-3951-028-1 | HOLDER ASSY, BT | | | | | |

6-2. ELECTRICAL PARTS LIST

NOTE:

- Due to standardization, replacements in the parts list may be different from the parts specified in the diagrams or the components used on the set.
- -XX and -X mean standardized parts, so they may have some difference from the original one.
- RESISTORS
All resistors are in ohms.
METAL: Metal-film resistor.
METAL OXIDE: Metal oxide-film resistor.
F: nonflammable
- Abbreviation
AUS : Australian model J : Japanese model
CN : Chinese model JE : Tourist model
CND : Canadian model KR : Korea model
HK : Hong Kong model

- Items marked “*” are not stocked since they are seldom required for routine service. Some delay should be anticipated when ordering these items.
- SEMICONDUCTORS
In each case, u: μ , for example:
uA. . : μ A. . uPA. . : μ PA. .
uPB. . : μ PB. . uPC. . : μ PC. .
uPD. . : μ PD. .
- CAPACITORS
uF: μ F
- COILS
uH: μ H

The components identified by mark Δ or dotted line with mark Δ are critical for safety. Replace only with part number specified.

Les composants identifiés par une marque Δ sont critiques pour la sécurité. Ne les remplacer que par une pièce portant le numéro spécifié.

When indicating parts by reference number, please include the board.

About PD-137 board and LCD module, discriminate LCD type on the machine referring to page 6, and replace the same type.

| Ref. No. | Part No. | Description | Remark | Ref. No. | Part No. | Description | Remark |
|----------|--------------|--|--------------------|----------|----------|-------------|--------|
| | A-7074-592-A | CD-290 BOARD, COMPLETE ***** (Ref. No.: 20,000 Series) (IC151 is not included in this complete board) | | | | | |
| | | < CAPACITOR > | | | | | |
| C152 | 1-162-966-11 | CERAMIC CHIP | 0.0022uF 10% 50V | | | | |
| C153 | 1-107-826-11 | CERAMIC CHIP | 0.1uF 10% 16V | | | | |
| C154 | 1-107-826-11 | CERAMIC CHIP | 0.1uF 10% 16V | | | | |
| C155 | 1-107-826-11 | CERAMIC CHIP | 0.1uF 10% 16V | | | | |
| C156 | 1-107-826-11 | CERAMIC CHIP | 0.1uF 10% 16V | | | | |
| C157 | 1-162-915-11 | CERAMIC CHIP | 10PF 0.5PF 50V | | | | |
| | | < IC > | | | | | |
| IC151 | A-7031-134-A | CCD BLOCK ASSY | | | | | |
| | | < TRANSISTOR > | | | | | |
| Q151 | 8-729-037-74 | TRANSISTOR | UN9213J- (K8).SO | | | | |
| Q152 | 8-729-050-22 | TRANSISTOR | 2SC4250 (T5LSONY1) | | | | |
| | | < RESISTOR > | | | | | |
| R153 | 1-216-826-11 | METAL CHIP | 2.7K 5% 1/16W | | | | |
| R154 | 1-216-805-11 | METAL CHIP | 47 5% 1/16W | | | | |
| R155 | 1-216-857-11 | METAL CHIP | 1M 5% 1/16W | | | | |
| R156 | 1-216-827-11 | METAL CHIP | 3.3K 5% 1/16W | | | | |
| R157 | 1-216-864-11 | METAL CHIP | 0 5% 1/16W | | | | |
| R158 | 1-216-814-11 | METAL CHIP | 270 5% 1/16W | | | | |

A-7074-605-A MT-60 BOARD, COMPLETE (SERVICE)

(Ref. No.: 10,000 Series)

(BT-2, CA-66, DD-150, HI-74 and PS-440 boards are included in this complete board)

Electrical parts list of the BT-2, CA-66, DD-150, HI-74, MT-60 and PS-440 board are not shown.
Pages 6-5 to 6-11 are not shown.

(Note) Be sure to read "Note on the CCD Imager Replacement" on page 4-8 when changing the CCD imager.

| Ref. No. | Part No. | Description | Remark | Ref. No. | Part No. | Description | Remark |
|--------------|--------------|-------------------------------|------------------|----------|--------------|----------------|---------------|
| A-7096-374-A | | PD-137 BLOCK ASSY (TYPE SA) | | | | < TRANSISTOR > | |
| | | ***** | | | | | |
| | | (Ref. No.: 10,000 Series) | | | | | |
| | | < CAPACITOR > | | | | | |
| C801 | 1-137-702-91 | TANTALUM CHIP | 1.5uF 20% 20V | Q801 | 8-729-050-76 | TRANSISTOR | EC3201C-PM-TL |
| C802 | 1-164-943-11 | CERAMIC CHIP | 0.01uF 10% 16V | Q802 | 8-729-050-74 | TRANSISTOR | 2SB1462LOAS0 |
| C803 | 1-137-700-91 | TANTALUM CHIP | 10uF 20% 6.3V | Q803 | 8-729-050-74 | TRANSISTOR | 2SB1462LOAS0 |
| C804 | 1-125-777-11 | CERAMIC CHIP | 0.1uF 10% 10V | Q804 | 8-729-050-74 | TRANSISTOR | 2SB1462LOAS0 |
| C805 | 1-125-777-11 | CERAMIC CHIP | 0.1uF 10% 10V | Q805 | 8-729-050-76 | TRANSISTOR | EC3201C-PM-TL |
| C806 | 1-125-838-11 | CERAMIC CHIP | 2.2uF 10% 6.3V | Q806 | 8-729-050-76 | TRANSISTOR | EC3201C-PM-TL |
| C807 | 1-164-943-11 | CERAMIC CHIP | 0.01uF 10% 16V | Q807 | 8-729-050-91 | TRANSISTOR | UNRL21300AS0 |
| C808 | 1-164-943-11 | CERAMIC CHIP | 0.01uF 10% 16V | Q809 | 8-729-050-91 | TRANSISTOR | UNRL21300AS0 |
| C809 | 1-164-943-11 | CERAMIC CHIP | 0.01uF 10% 16V | Q812 | 8-729-050-76 | TRANSISTOR | EC3201C-PM-TL |
| C810 | 1-125-777-11 | CERAMIC CHIP | 0.1uF 10% 10V | Q813 | 8-729-050-74 | TRANSISTOR | 2SB1462LOAS0 |
| C811 | 1-127-760-11 | CERAMIC CHIP | 4.7uF 10% 6.3V | Q814 | 8-729-050-76 | TRANSISTOR | EC3201C-PM-TL |
| C812 | 1-127-760-11 | CERAMIC CHIP | 4.7uF 10% 6.3V | | | < RESISTOR > | |
| C813 | 1-127-760-11 | CERAMIC CHIP | 4.7uF 10% 6.3V | R801 | 1-218-970-11 | RES-CHIP | 27K 5% 1/16W |
| C814 | 1-125-777-11 | CERAMIC CHIP | 0.1uF 10% 10V | R802 | 1-218-969-11 | RES-CHIP | 22K 5% 1/16W |
| C815 | 1-164-505-11 | CERAMIC CHIP | 2.2uF 16V | R803 | 1-218-965-11 | RES-CHIP | 10K 5% 1/16W |
| C816 | 1-164-505-11 | CERAMIC CHIP | 2.2uF 16V | R804 | 1-218-941-11 | RES-CHIP | 100 5% 1/16W |
| C817 | 1-107-686-11 | TANTALUM CHIP | 4.7uF 20% 16V | R805 | 1-218-941-11 | RES-CHIP | 100 5% 1/16W |
| C818 | 1-137-700-91 | TANTALUM CHIP | 10uF 20% 6.3V | R806 | 1-218-941-11 | RES-CHIP | 100 5% 1/16W |
| C820 | 1-125-777-11 | CERAMIC CHIP | 0.1uF 10% 10V | R807 | 1-218-941-11 | RES-CHIP | 100 5% 1/16W |
| C821 | 1-107-826-11 | CERAMIC CHIP | 0.1uF 10% 16V | R808 | 1-218-969-11 | RES-CHIP | 22K 5% 1/16W |
| C822 | 1-125-777-11 | CERAMIC CHIP | 0.1uF 10% 10V | R809 | 1-218-977-11 | RES-CHIP | 100K 5% 1/16W |
| C823 | 1-125-777-11 | CERAMIC CHIP | 0.1uF 10% 10V | R810 | 1-218-961-11 | RES-CHIP | 4.7K 5% 1/16W |
| C824 | 1-164-943-11 | CERAMIC CHIP | 0.01uF 10% 16V | R811 | 1-218-971-11 | RES-CHIP | 33K 5% 1/16W |
| C825 | 1-127-760-11 | CERAMIC CHIP | 4.7uF 10% 6.3V | R812 | 1-218-973-11 | RES-CHIP | 47K 5% 1/16W |
| C826 | 1-164-940-11 | CERAMIC CHIP | 0.0033uF 10% 16V | R813 | 1-218-971-11 | RES-CHIP | 33K 5% 1/16W |
| C827 | 1-164-868-11 | CERAMIC CHIP | 56PF 5% 16V | R814 | 1-218-973-11 | RES-CHIP | 47K 5% 1/16W |
| C828 | 1-125-777-11 | CERAMIC CHIP | 0.1uF 10% 10V | R815 | 1-218-969-11 | RES-CHIP | 22K 5% 1/16W |
| C829 | 1-164-937-11 | CERAMIC CHIP | 0.001uF 10% 16V | R816 | 1-218-971-11 | RES-CHIP | 33K 5% 1/16W |
| C832 | 1-107-823-11 | CERAMIC CHIP | 0.47uF 10% 16V | R817 | 1-218-972-11 | RES-CHIP | 39K 5% 1/16W |
| | | < CONNECTOR > | | R818 | 1-218-973-11 | RES-CHIP | 47K 5% 1/16W |
| CN805 | 1-794-770-21 | CONNECTOR, FFC/FPC (LIF) 24P | | R821 | 1-218-965-11 | RES-CHIP | 10K 5% 1/16W |
| CN806 | 1-794-766-21 | CONNECTOR, FFC/FPC (LIF) 6P | | R822 | 1-218-961-11 | RES-CHIP | 4.7K 5% 1/16W |
| CN881 | 1-794-769-21 | CONNECTOR, FFC/FPC (LIF) 18P | | R823 | 1-218-973-11 | RES-CHIP | 47K 5% 1/16W |
| CN882 | 1-794-768-21 | CONNECTOR, FFC/FPC (LIF) 11P | | R824 | 1-218-973-11 | RES-CHIP | 47K 5% 1/16W |
| CN883 | 1-778-804-11 | CONNECTOR, BOARD TO BOARD 40P | | R825 | 1-218-990-11 | SHORT | 0 |
| CN884 | 1-794-411-21 | CONNECTOR, FFC/FPC (LIF) 8P | | R826 | 1-218-977-11 | RES-CHIP | 100K 5% 1/16W |
| | | < DIODE > | | R827 | 1-218-965-11 | RES-CHIP | 10K 5% 1/16W |
| D802 | 8-713-102-80 | DIODE 1T369-01-T8A | | R828 | 1-218-941-11 | RES-CHIP | 100 5% 1/16W |
| D880 | 8-719-062-16 | DIODE 01ZA8.2 (TPL3) | | R829 | 1-218-941-11 | RES-CHIP | 100 5% 1/16W |
| | | < IC > | | R830 | 1-218-941-11 | RES-CHIP | 100 5% 1/16W |
| IC801 | 8-759-524-98 | IC CXA8116R-T4 | | R832 | 1-218-989-11 | RES-CHIP | 1M 5% 1/16W |
| IC802 | 8-759-364-05 | IC MB40D001PFV-G-BND-ER | | R833 | 1-218-975-11 | RES-CHIP | 68K 5% 1/16W |
| IC803 | 8-759-337-40 | IC NJM2904V (TE2) | | R834 | 1-218-972-11 | RES-CHIP | 39K 5% 1/16W |
| IC804 | 8-759-677-84 | IC LC12017-52T-TE-B | | R835 | 1-218-965-11 | RES-CHIP | 10K 5% 1/16W |
| | | < COIL > | | R836 | 1-218-981-11 | RES-CHIP | 220K 5% 1/16W |
| L801 | 1-469-757-21 | INDUCTOR | 10uH | R837 | 1-218-969-11 | RES-CHIP | 22K 5% 1/16W |
| L802 | 1-469-528-91 | INDUCTOR | 100uH | R840 | 1-218-990-11 | SHORT | 0 |
| L803 | 1-469-757-21 | INDUCTOR | 10uH | R841 | 1-218-971-11 | RES-CHIP | 33K 5% 1/16W |
| L804 | 1-412-949-21 | INDUCTOR | 6.8uH | R842 | 1-218-977-11 | RES-CHIP | 100K 5% 1/16W |
| L805 | 1-469-757-21 | INDUCTOR | 10uH | R843 | 1-218-974-11 | RES-CHIP | 56K 5% 1/16W |
| | | | | R845 | 1-218-981-11 | RES-CHIP | 220K 5% 1/16W |
| | | | | R846 | 1-218-970-11 | RES-CHIP | 27K 5% 1/16W |
| | | | | R847 | 1-218-973-11 | RES-CHIP | 47K 5% 1/16W |
| | | | | R848 | 1-218-975-11 | RES-CHIP | 68K 5% 1/16W |
| | | | | R849 | 1-218-965-11 | RES-CHIP | 10K 5% 1/16W |
| | | | | R851 | 1-218-965-11 | RES-CHIP | 10K 5% 1/16W |
| | | | | R854 | 1-218-971-11 | RES-CHIP | 33K 5% 1/16W |

PD-137 (TYPE SA)

PD-137 (TYPE ST)

| Ref. No. | Part No. | Description | Remark |
|------------|--------------|-----------------------------|--------|
| R855 | 1-218-953-11 | RES-CHIP 1K 5% | 1/16W |
| R856 | 1-218-990-11 | SHORT 0 | |
| R857 | 1-218-990-11 | SHORT 0 | |
| R859 | 1-218-990-11 | SHORT 0 | |
| R860 | 1-469-082-21 | FERRITE 600uH (Note) | |
| R861 | 1-218-975-11 | RES-CHIP 68K 5% | 1/16W |
| R862 | 1-218-977-11 | RES-CHIP 100K 5% | 1/16W |
| R863 | 1-216-864-11 | METAL CHIP 0 5% | 1/16W |
| R864 | 1-216-864-11 | METAL CHIP 0 5% | 1/16W |
| R865 | 1-216-864-11 | METAL CHIP 0 5% | 1/16W |
| R868 | 1-218-964-11 | RES-CHIP 8.2K 5% | 1/16W |
| R869 | 1-218-953-11 | RES-CHIP 1K 5% | 1/16W |
| R871 | 1-211-989-11 | METAL CHIP 68 0.5% | 1/16W |
| R872 | 1-218-990-11 | SHORT 0 | |
| R873 | 1-218-990-11 | SHORT 0 | |
| R874 | 1-218-990-11 | SHORT 0 | |
| R875 | 1-218-990-11 | SHORT 0 | |
| R876 | 1-218-990-11 | SHORT 0 | |
| R877 | 1-211-989-11 | METAL CHIP 68 0.5% | 1/16W |
| R878 | 1-218-964-11 | RES-CHIP 8.2K 5% | 1/16W |
| R882 | 1-218-990-11 | SHORT 0 | |
| R888 | 1-469-082-21 | FERRITE 600uH (Note) | |
| R889 | 1-469-082-21 | FERRITE 600uH (Note) | |
| R890 | 1-218-956-11 | RES-CHIP 1.8K 5% | 1/16W |
| R891 | 1-218-956-11 | RES-CHIP 1.8K 5% | 1/16W |
| R892 | 1-218-958-11 | RES-CHIP 2.7K 5% | 1/16W |
| R893 | 1-218-958-11 | RES-CHIP 2.7K 5% | 1/16W |
| < SWITCH > | | | |
| S881 | 1-771-138-61 | SWITCH, KEY BOARD (DISPLAY) | |
| S882 | 1-786-039-21 | SWITCH, TACTILE (CONTROL) | |

A-7096-373-A PD-137 BLOCK ASSY (TYPE ST)

 (Ref. No.: 10,000 Series)

< CAPACITOR >

| | | | |
|------|--------------|-------------------------|------|
| C801 | 1-137-702-91 | TANTALUM CHIP 1.5uF 20% | 20V |
| C802 | 1-164-943-11 | CERAMIC CHIP 0.01uF 10% | 16V |
| C803 | 1-137-700-91 | TANTALUM CHIP 10uF 20% | 6.3V |
| C804 | 1-125-777-11 | CERAMIC CHIP 0.1uF 10% | 10V |
| C805 | 1-125-777-11 | CERAMIC CHIP 0.1uF 10% | 10V |
| C806 | 1-125-838-11 | CERAMIC CHIP 2.2uF 10% | 6.3V |
| C807 | 1-164-943-11 | CERAMIC CHIP 0.01uF 10% | 16V |
| C808 | 1-164-943-11 | CERAMIC CHIP 0.01uF 10% | 16V |
| C809 | 1-164-943-11 | CERAMIC CHIP 0.01uF 10% | 16V |
| C810 | 1-125-777-11 | CERAMIC CHIP 0.1uF 10% | 10V |
| C811 | 1-127-760-11 | CERAMIC CHIP 4.7uF 10% | 6.3V |
| C812 | 1-127-760-11 | CERAMIC CHIP 4.7uF 10% | 6.3V |
| C813 | 1-127-760-11 | CERAMIC CHIP 4.7uF 10% | 6.3V |
| C814 | 1-125-777-11 | CERAMIC CHIP 0.1uF 10% | 10V |
| C815 | 1-164-505-11 | CERAMIC CHIP 2.2uF | 16V |
| C816 | 1-164-505-11 | CERAMIC CHIP 2.2uF | 16V |
| C817 | 1-107-686-11 | TANTALUM CHIP 4.7uF 20% | 16V |
| C818 | 1-137-700-91 | TANTALUM CHIP 10uF 20% | 6.3V |
| C820 | 1-125-777-11 | CERAMIC CHIP 0.1uF 10% | 10V |
| C821 | 1-107-826-11 | CERAMIC CHIP 0.1uF 10% | 16V |

| Ref. No. | Part No. | Description | Remark |
|----------------|--------------|---------------------------------|--------|
| C822 | 1-125-777-11 | CERAMIC CHIP 0.1uF 10% | 10V |
| C823 | 1-125-777-11 | CERAMIC CHIP 0.1uF 10% | 10V |
| C824 | 1-164-943-11 | CERAMIC CHIP 0.01uF 10% | 16V |
| C825 | 1-127-760-11 | CERAMIC CHIP 4.7uF 10% | 6.3V |
| C826 | 1-164-940-11 | CERAMIC CHIP 0.0033uF 10% | 16V |
| C827 | 1-164-868-11 | CERAMIC CHIP 56PF 5% | 16V |
| C828 | 1-125-777-11 | CERAMIC CHIP 0.1uF 10% | 10V |
| C829 | 1-164-937-11 | CERAMIC CHIP 0.001uF 10% | 16V |
| C830 | 1-109-982-11 | CERAMIC CHIP 1uF 10% | 10V |
| C831 | 1-110-501-11 | CERAMIC CHIP 0.33uF 10% | 16V |
| C832 | 1-107-823-11 | CERAMIC CHIP 0.47uF 10% | 16V |
| < CONNECTOR > | | | |
| CN805 | 1-794-770-21 | CONNECTOR, FFC/FPC (LIF) 24P | |
| CN806 | 1-794-766-21 | CONNECTOR, FFC/FPC (LIF) 6P | |
| CN881 | 1-794-769-21 | CONNECTOR, FFC/FPC (LIF) 18P | |
| CN882 | 1-794-768-21 | CONNECTOR, FFC/FPC (LIF) 11P | |
| CN883 | 1-778-804-11 | CONNECTOR, BOARD TO BOARD 40P | |
| CN884 | 1-794-411-21 | CONNECTOR, FFC/FPC (LIF) 8P | |
| < DIODE > | | | |
| D802 | 8-713-102-80 | DIODE 1T369-01-T8A | |
| D803 | 8-719-050-42 | DIODE RD3.3UM-T1B | |
| D880 | 8-719-062-16 | DIODE 01ZA8.2 (TPL3) | |
| < IC > | | | |
| IC801 | 8-759-524-98 | IC CXA8116R-T4 | |
| IC802 | 8-759-364-05 | IC MB40D001PFV-G-BND-ER | |
| IC803 | 8-759-337-40 | IC NJM2904V (TE2) | |
| IC804 | 8-752-405-01 | IC CXD3510R-T4 | |
| < COIL > | | | |
| L801 | 1-469-757-21 | INDUCTOR 10uH | |
| L802 | 1-469-528-91 | INDUCTOR 100uH | |
| L803 | 1-469-757-21 | INDUCTOR 10uH | |
| L804 | 1-412-949-21 | INDUCTOR 6.8uH | |
| L805 | 1-469-757-21 | INDUCTOR 10uH | |
| < TRANSISTOR > | | | |
| Q801 | 8-729-050-76 | TRANSISTOR EC3201C-PM-TL | |
| Q802 | 8-729-050-74 | TRANSISTOR 2SB1462L0AS0 | |
| Q803 | 8-729-050-74 | TRANSISTOR 2SB1462L0AS0 | |
| Q804 | 8-729-050-74 | TRANSISTOR 2SB1462L0AS0 | |
| Q805 | 8-729-050-76 | TRANSISTOR EC3201C-PM-TL | |
| Q806 | 8-729-050-76 | TRANSISTOR EC3201C-PM-TL | |
| Q811 | 8-729-037-53 | TRANSISTOR 2SA1832F-Y/GR (TPL3) | |
| Q812 | 8-729-050-76 | TRANSISTOR EC3201C-PM-TL | |
| Q813 | 8-729-050-74 | TRANSISTOR 2SB1462L0AS0 | |
| Q814 | 8-729-050-76 | TRANSISTOR EC3201C-PM-TL | |
| < RESISTOR > | | | |
| R801 | 1-218-970-11 | RES-CHIP 27K 5% | 1/16W |
| R802 | 1-218-969-11 | RES-CHIP 22K 5% | 1/16W |
| R803 | 1-218-965-11 | RES-CHIP 10K 5% | 1/16W |
| R804 | 1-218-941-11 | RES-CHIP 100 5% | 1/16W |
| R805 | 1-218-941-11 | RES-CHIP 100 5% | 1/16W |
| R806 | 1-218-941-11 | RES-CHIP 100 5% | 1/16W |
| R807 | 1-218-941-11 | RES-CHIP 100 5% | 1/16W |

Note: Ferrite beads are mounted to the location where R860, R888 and R889 are printed.

ST-62

SW-349

ZM-26

| Ref. No. | Part No. | Description | Remark |
|----------|--------------|---|---------------------------|
| △ | A-7074-599-A | ST-62 BOARD, COMPLETE ***** | (Ref. No.: 10,000 Series) |
| △ | 1-476-293-11 | FLASH UNIT | |
| | 3-064-224-01 | HOLDER, LIGHT REGULATION | |
| | | < CAPACITOR > | |
| | C1001 | 1-162-966-11 CERAMIC CHIP | 0.0022uF 10% 50V |
| △ | C1002 | 1-137-723-21 CERAMIC CHIP | 0.047uF 10% 250V |
| △ | C1003 | 1-137-724-11 ELECT | 95uF 300V |
| | C1051 | 1-104-852-11 TANTALUM CHIP | 22uF 20% 10V |
| | C1052 | 1-165-176-11 CERAMIC CHIP | 0.047uF 10% 16V |
| | C1053 | 1-125-817-11 CERAMIC CHIP | 10uF 10% 6.3V |
| | C1054 | 1-162-970-11 CERAMIC CHIP | 0.01uF 10% 25V |
| | C1055 | 1-109-982-11 CERAMIC CHIP | 1uF 10% 10V |
| | C1056 | 1-109-982-11 CERAMIC CHIP | 1uF 10% 10V |
| | | < DIODE > | |
| △ | D1001 | 8-719-081-37 DIODE HAU140C028TP | |
| | D1051 | 8-719-073-01 DIODE MA111- (K8).SO | |
| | | < COIL > | |
| | L1051 | 1-414-392-41 INDUCTOR | 1uH |
| | | < TRANSISTOR > | |
| △ | Q1002 | 8-729-053-74 TRANSISTOR | CY25AAJ-8-T13 |
| | Q1003 | 8-729-053-77 PHOTO TRANSISTOR | PN126S-R.S0 |
| | Q1051 | 8-729-426-24 TRANSISTOR | XP1211-TXE |
| | Q1052 | 8-729-037-74 TRANSISTOR | UN9213J- (K8).SO |
| | Q1053 | 8-729-015-74 TRANSISTOR | UN5111-TX |
| | Q1054 | 8-729-422-87 TRANSISTOR | 2SB1073-R-TX |
| | Q1055 | 8-729-037-52 TRANSISTOR | 2SD2216J-QR (K8).SO |
| | Q1056 | 8-729-422-87 TRANSISTOR | 2SB1073-R-TX |
| | Q1057 | 8-729-426-24 TRANSISTOR | XP1211-TXE |
| | Q1058 | 8-729-042-58 TRANSISTOR | UN9111J- (K8).SO |
| | | < RESISTOR > | |
| △ | R1002 | 1-216-286-00 RES-CHIP | 4.7M 5% 1/8W |
| | R1003 | 1-216-805-11 METAL CHIP | 47 5% 1/16W |
| | R1004 | 1-216-857-11 METAL CHIP | 1M 5% 1/16W |
| | R1051 | 1-216-829-11 METAL CHIP | 4.7K 5% 1/16W |
| | R1052 | 1-216-845-11 METAL CHIP | 100K 5% 1/16W |
| | R1053 | 1-216-809-11 METAL CHIP | 100 5% 1/16W |
| | R1054 | 1-216-821-11 METAL CHIP | 1K 5% 1/16W |
| | R1055 | 1-216-811-11 METAL CHIP | 150 5% 1/16W |
| | R1056 | 1-216-805-11 METAL CHIP | 47 5% 1/16W |
| | R1058 | 1-216-838-11 METAL CHIP | 27K 5% 1/16W |
| | R1060 | 1-216-826-11 METAL CHIP | 2.7K 5% 1/16W |
| | R1061 | 1-216-814-11 METAL CHIP | 270 5% 1/16W |
| | R1062 | 1-216-829-11 METAL CHIP | 4.7K 5% 1/16W |
| | R1063 | 1-216-833-11 METAL CHIP | 10K 5% 1/16W |
| | | < TRANSFORMER > | |
| △ | T1001 | 1-435-741-21 TRANSFORMER, DC-DC CONVERTER | |
| △ | T1002 | 1-419-828-11 COIL, TRIGGER | |

| Ref. No. | Part No. | Description | Remark |
|----------|--------------|--------------------------------|---------------------------|
| | A-7096-375-A | SW-349 BLOCK ASSY ***** | (Ref. No.: 20,000 Series) |
| | | < DIODE > | |
| D002 | 8-719-070-94 | DIODE TLYU1008 (T05, SOY) | (STROBE CHARGE) |
| D006 | 8-719-070-91 | DIODE TLSU1008 (T05, SOY) | (SELF-TIMER/RECORDING) |
| D007 | 8-719-070-95 | DIODE TLGU1008 (T05, SOY) | (AE LOCK) |
| D008 | 8-719-056-61 | DIODE MAZS082008SO | |
| | | < RESISTOR > | |
| R003 | 1-216-824-11 | METAL CHIP | 1.8K 5% 1/16W |
| R008 | 1-216-829-11 | METAL CHIP | 4.7K 5% 1/16W |
| R010 | 1-216-831-11 | METAL CHIP | 6.8K 5% 1/16W |
| R011 | 1-216-829-11 | METAL CHIP | 4.7K 5% 1/16W |
| R012 | 1-216-839-11 | METAL CHIP | 33K 5% 1/16W |
| R013 | 1-216-831-11 | METAL CHIP | 6.8K 5% 1/16W |
| R018 | 1-216-819-11 | METAL CHIP | 680 5% 1/16W |
| R019 | 1-216-820-11 | METAL CHIP | 820 5% 1/16W |
| R022 | 1-216-836-11 | METAL CHIP | 18K 5% 1/16W |
| | | < SWITCH > | |
| S002 | 1-771-138-61 | SWITCH, KEY BOARD (FLASH) | |
| S003 | 1-771-138-61 | SWITCH, KEY BOARD (MACRO) | |
| S005 | 1-771-138-61 | SWITCH, KEY BOARD (VOLUME +) | |
| S006 | 1-771-138-61 | SWITCH, KEY BOARD (LCD ON/OFF) | |
| S007 | 1-771-138-61 | SWITCH, KEY BOARD (VOLUME -) | |
| S008 | 1-771-138-61 | SWITCH, KEY BOARD (PROGRAM AE) | |
| | A-7074-603-A | ZM-26 BOARD, COMPLETE ***** | (Ref. No.: 20,000 Series) |
| | | < DIODE > | |
| D053 | 8-719-056-23 | DIODE 1SS387-TPL3 | |
| D054 | 8-719-056-53 | DIODE MAZS051008SO | |
| D055 | 8-719-056-53 | DIODE MAZS051008SO | |
| D056 | 8-719-056-53 | DIODE MAZS051008SO | |
| D057 | 8-719-062-16 | DIODE 01ZA8.2 (TPL3) | |
| | | < FERRITE BEAD > | |
| FB051 | 1-500-284-21 | INDUCTOR | 0uH |
| FB052 | 1-216-295-11 | SHORT | 0 (Note) |
| FB053 | 1-500-284-21 | INDUCTOR | 0uH |
| | | < JACK > | |
| J052 | 1-569-950-31 | JACK (SMALL TYPE) (A/V OUT) | |
| | | < RESISTOR > | |
| R051 | 1-216-826-11 | METAL CHIP | 2.7K 5% 1/16W |
| R052 | 1-216-821-11 | METAL CHIP | 1K 5% 1/16W |
| R053 | 1-216-864-11 | METAL CHIP | 0 5% 1/16W |
| | | < SPEAKER > | |
| SP901 | 1-529-857-11 | SPEAKER (1.6 cm) | |

Note: Resistor is mounted to the location where FB052 is printed.

The components identified by mark △ or dotted line with mark △ are critical for safety. Replace only with part number specified.

Les composants identifiés par une marque △ sont critiques pour la sécurité. Ne les remplacer que par une pièce portant le numéro spécifié.

| Ref. No. | Part No. | Description | Remark |
|----------|--------------|------------------------------|--------|
| | | < SWITCH > | |
| S051 | 1-771-138-61 | SWITCH, KEY BOARD (ZOOM (T)) | |
| S052 | 1-771-138-61 | SWITCH, KEY BOARD (ZOOM (W)) | |

ACCESSORIES

| | | |
|---|--------------|--|
| △ | 1-476-332-11 | ADAPTOR, AC (AC-LSI) (US, CND, JE, J) |
| △ | 1-476-332-21 | ADAPTOR, AC (AC-LSI) (CN) |
| △ | 1-476-332-31 | ADAPTOR, AC (AC-LSI) (KR) |
| △ | 1-476-332-41 | ADAPTOR, AC (AC-LSI) (AEP, UK, E, HK, AUS) |
| | 1-543-798-11 | FILTER, CLAMP (FERRITE CORE) (AEP, UK, AUS) |
| △ | 1-569-007-11 | ADAPTOR, CONVERSION 2P (E, JE) |
| △ | 1-569-008-21 | ADAPTOR, CONVERSION 2P (E) |
| △ | 1-696-819-11 | CORD, POWER (AUS) |
| | 1-757-293-11 | CORD, CONNECTION (USB 5P) |
| △ | 1-769-608-11 | CORD, POWER (AEP, E) |
| △ | 1-776-985-11 | CORD, POWER (KR) |
| △ | 1-782-476-11 | CORD, POWER (CN) |
| △ | 1-783-374-11 | CORD, POWER (UK, HK) |
| | 1-783-738-31 | CORD, CONNECTION (AV CONNECTING 1.5m) |
| △ | 1-790-107-22 | CORD, POWER (US, CND) |
| △ | 1-790-732-11 | CORD, POWER (JE, J) |
| | 3-050-664-11 | STRAP, HAND |
| | 3-063-797-01 | SOFT, BUNDLE |
| | 3-064-296-01 | MANUAL, INSTRUCTION (JAPANESE) (J) |
| | 3-064-296-11 | MANUAL, INSTRUCTION (ENGLISH) (EXCEPT KR, J) |
| | 3-064-296-21 | MANUAL, INSTRUCTION (FRENCH, GERMAN) (CND, AEP, AUS, JE) |
| | 3-064-296-31 | MANUAL, INSTRUCTION (SPANISH, PORTUGUESE) (AEP, E, AUS, JE) |
| | 3-064-296-41 | MANUAL, INSTRUCTION (ITALIAN, DUTCH) (AEP) |
| | 3-064-296-51 | MANUAL, INSTRUCTION (CHINESE) (E, HK, AUS, CN, JE) |
| | 3-064-296-61 | MANUAL, INSTRUCTION (RUSSIAN, SWEDISH) (AEP, AUS, JE) |
| | 3-064-296-71 | MANUAL, INSTRUCTION (ARABIC) (E) |
| | 3-064-296-81 | MANUAL, INSTRUCTION (KOREAN) (AUS, KR, JE) |
| | 3-064-377-01 | REGISTRATION CD-ROM (DSC-V3.1) (J) |
| | 3-866-482-01 | MANUAL, INSTRUCTION (for SAFETY) (JAPANESE) (J) |

FOR CAMERA COLOR REPRODUCTION ADJUSTMENT

Take a copy of CAMERA COLOR REPRODUCTION FRAME with a clear sheet for use.

For NTSC mode

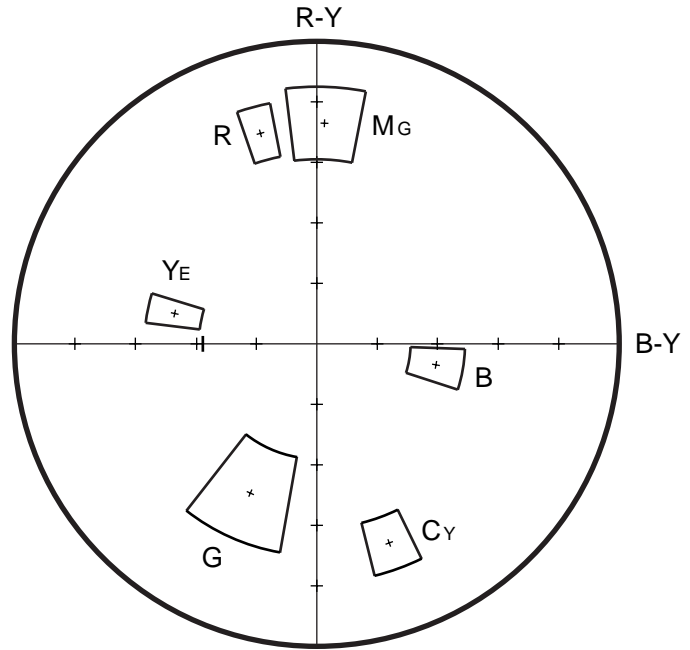

DSC-P1



For PAL mode

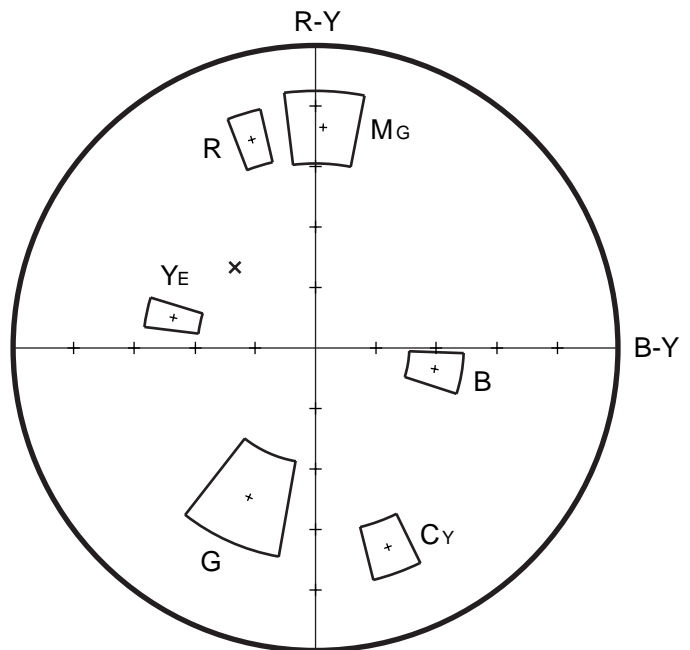

DSC-P1



